



PVCHECKS-ONE

User manual



TABLE OF CONTENTS

1. PRECAUTIONS AND SAFETY MEASURES	3
1.1. Preliminary instructions.....	3
1.2. During use.....	4
1.3. After use.....	4
1.4. Definition of measurement (overvoltage) category.....	4
2. GENERAL DESCRIPTION	5
2.1. Foreword.....	5
2.2. Instrument functions	5
3. PREPARATION FOR USE	6
3.1. Initial checks.....	6
3.2. Instrument power supply.....	6
3.3. Storage.....	6
4. NOMENCLATURE.....	7
4.1. Description of the instrument	7
4.2. Keyboard description.....	8
4.3. Initial screen	8
5. GENERAL MENU	9
5.1. SET – instrument settings.....	9
5.1.1. Language	9
5.1.2. Date/Time.....	10
5.1.3. General settings.....	10
5.1.4. Irradiance & Temperature	10
5.1.5. Information.....	11
5.1.6. Operator name.....	11
6. OPERATING INSTRUCTIONS.....	12
6.1. DMM – Multimeter function.....	12
6.2. UREM – Remote unit.....	13
6.3. RPE – Continuity measurement on PV modules/strings/fields	16
6.3.1. Calibration of measuring cables.....	16
6.3.2. Carrying out continuity measurements in Standard (STD) mode	18
6.3.3. Carrying out continuity measurements in Timer (TMR) mode	20
6.3.4. Anomalous situations.....	22
6.4. MΩ – Measurement of insulation on PV modules/strings/fields.....	23
6.4.1. Measuring insulation – DUAL mode	24
6.4.2. Measuring insulation – TMR mode	25
6.4.3. Anomalous situations.....	28
6.5. GFL – Searching for conditions of low insulation on PV strings	30
6.6. OPT – Insulation measurement with power optimizers	34
6.6.1. Insulation measurement with optimizers having RSD function.....	35
6.6.2. Insulation measurement with optimizers without RSD function	37
6.6.3. Anomalous situations.....	39
6.7. DB – Module database management.....	41
6.7.1. How to define a new PV module.....	41
6.7.2. How to modify an existing PV module	43
6.7.3. How to delete an existing PV module	43
6.8. IVCK - Test on PV modules and strings.....	44
6.8.1. Foreword.....	44
6.8.2. IVCK Tests without remote unit and without irradiance measurement.....	46
6.8.3. IVCK Tests without remote unit and irradiance measurement in direct mode	50
6.8.4. IVCK Tests with remote unit in direct connection	54
6.8.5. IVCK Tests with remote unit in recording	59
6.8.6. IVCK Tests with Start&Save function.....	65
6.8.7. Interpretation of measurement results	68
6.8.8. Anomalous situations.....	71
6.9. List of error messages on the display	74
7. STORING RESULTS.....	75
7.1. Saving measures.....	75

7.2.	Recalling and deletion of saved data	76
8.	CONNECTING THE INSTRUMENT TO THE PC	78
9.	MAINTENANCE.....	79
9.1.	General information	79
9.2.	Battery replacement	79
9.3.	Cleaning the instrument.....	79
9.4.	End of life	79
10.	TECHNICAL SPECIFICATIONS	80
10.1.	Technical characteristics	80
10.2.	General characteristics.....	82
10.3.	Environmental conditions for use.....	83
10.4.	Accessories	83
11.	APPENDIX – THEORETICAL OUTLINE	84
11.1.	Measurement of polarization index (PI)	84
11.2.	Dielectric Absorption Ratio (DAR).....	84
11.3.	GFL Function – Theoretical aspects and references guidelines.....	85
11.4.	DUAL and TMR functions – Technical insights	87
11.4.1.	Regulatory and theoretical aspects of insulation measurement	87
11.5.	MLPE general characteristics (Optimizers and RSD devices).....	90
11.5.1.	Features of RSD devices	90
11.5.2.	General characteristics of power optimizers	90
11.5.3.	IVCK or I-V curve test on MLPE devices	91
11.5.4.	Insulation measurement on MLPE devices (OPT function)	91
11.5.5.	Types of isolation measurements with power optimizers	92
12.	ASSISTANCE	93
12.1.	Warranty conditions.....	93
12.2.	Assistance.....	93

1. PRECAUTIONS AND SAFETY MEASURES

The instrument has been designed in compliance with directive IEC/EN61010-1 relevant to electronic measuring instruments. Before and while carrying out measurements, observe the following indications and read all notes preceded by the symbol  with the utmost attention.

- Do not carry out any voltage or current measurement in humid environments
- Do not carry out any measurements in case gas, explosive materials or flammables are present, or in dusty environments
- Avoid any contact with the circuit being measured if no measurements are being carried out.
- Avoid contact with exposed metal parts, with unused measuring probes, etc.
- Do not carry out any measurement in case you find anomalies in the instrument such as deformation, breaks, absence of display on the screen, etc.
- Pay special attention when measuring voltages higher than 25V in special environments and 50V in normal environments, since a risk of electrical shock exists.

In this manual, and on the instrument, the following symbols are used:



Warning: observe the instructions given in this manual; improper use could damage the instrument or its components.



High voltage danger: electrical shock hazard.



Double insulation



DC Voltage or Current



AC Voltage



Connection to earth

1.1. PRELIMINARY INSTRUCTIONS



- **The instrument has been designed to be used in the environmental conditions specified in § 10.3. The presence of significantly different environmental conditions can compromise the safety of the instrument and the operator. In any case, before using, wait until the conditions inside the instrument are comparable to the conditions of the environment in which it is operating**
- The instrument may be used for measuring **VOLTAGE** and **CURRENT** in CAT III 1000V with maximum voltage 1000VDC and 1000V AC between inputs. Do not use it on circuits exceeding the limit values specified in § 10.1
- We recommend following the normal safety rules devised to protect the user against dangerous currents and the instrument against incorrect use.
- Only the accessories provided together with the instrument will guarantee safety standards. They must be in good conditions and replaced with identical models, when necessary.
- Make sure that batteries are correctly installed.
- Before connecting the measuring cables to the circuit being measured, check that the desired function has been selected.

1.2. DURING USE

Please carefully read the following recommendations and instructions:



CAUTION

- Failure to comply with the caution notes and/or instructions may damage the instrument and/or its components or be a source of danger for the operator.
- The symbol “” indicates a full charge level of the internal batteries. When battery charge decreases to a minimum level, the symbol “” appears on the display. In this case, stop testing and replace the batteries according to the indications given in § 9.2
- **In any function, even without activating the test, if the instrument detects a voltage >1000V it emits an acoustic warning signal**
- **The instrument can keep data stored even without batteries**

1.3. AFTER USE

When measurements are complete, switch off the instrument by pressing and holding the **ON/OFF** key for some seconds. If the instrument is not to be used for a long time, remove the batteries and follow the instructions given in § 3.3.

1.4. DEFINITION OF MEASUREMENT (OVERVOLTAGE) CATEGORY

Standard “IEC/EN61010-1: Safety requirements for electrical equipment for measurement, control and laboratory use, Part 1: General requirements”, defines what measurement category, commonly called overvoltage category, is. Al § 6.7.4: Measured circuits, reads:

Circuits are divided into the following measurement categories:

- **Measurement category IV** is for measurements performed at the source of the low-voltage installation.
Examples are electricity meters and measurements on primary overcurrent protection devices and ripple control units.
- **Measurement category III** is for measurements performed on installations inside buildings.
Examples are measurements on distribution boards, circuit breakers, wiring, including cables, bus-bars, junction boxes, switches, socket-outlets in the fixed installation, and equipment for industrial use and some other equipment, for example, stationary motors with permanent connection to fixed installation.
- **Measurement category II** is for measurements performed on circuits directly connected to the low-voltage installation.
Examples are measurements on household appliances, portable tools and similar equipment.
- **Measurement category I** is for measurements performed on circuits not directly connected to MAINS.
Examples are measurements on circuits not derived from MAINS, and specially protected (internal) MAINS-derived circuits. In the latter case, transient stresses are variable; for that reason, the standard requires that the transient withstanding capability of the equipment is made known to the user.

2. GENERAL DESCRIPTION

2.1. FOREWORD

This instrument has been designed to carry out quick tests (IVCK) on photovoltaic (PV) modules/strings in compliance with standard IEC/EN62446-1.

2.2. INSTRUMENT FUNCTIONS

The instrument has the following features:

Continuity test of protective conductors (RPE)

- Test with test current > 200mA in compliance with standards IEC/EN62446-1, and IEC/EN61557-4
- Manual calibration of measuring cables.

Measurement of insulation resistance on PV modules/strings (M Ω)

- Test voltages of 250V, 500V, 1000VDC in compliance with standards IEC/EN62446-1 and IEC/EN61557-2
- 2 available measuring modes
 - DUAL → Measurement in a sequence of the insulation between the string's positive pole (+) and PE and between the string's negative pole and PE.
 - TMR → single timed measurement between the string's negative pole and PE.

GFL (Ground Fault Locator) function to search for positions with a low insulation among the modules of a PV string (see § 6.5).

OPT (Optimizer) function for insulation resistance measurements on PVstrings in presence of Optimizers (see § 6.6)

Measurement of open-circuit voltage and short circuit current on monofacial or bifacial PV modules/strings in compliance with standard IEC/EN62446-1 and IEC/EN60891 (IVCK)

- Measurement of open-circuit voltage Voc on monofacial and bifacial PV modules/strings up to 1000VDC with or without irradiance
- Measurement of short-circuit current Isc on monofacial and bifacial PV modules/strings up to 30A with or without irradiance
- Monofacial modules → Measurement of frontal irradiance by direct connection of the HT305 reference cell
- Bifacial Modules → Measurement of front and rear irradiance via connection with SOLAR03 remote unit and HT305 reference cells
- Measurement of module temperature in compliance with the IEC/EN60904-5 guideline (AUTO mode) or via the PT305 probe (connected to the **TEMP** input of the instrument or to the SOLAR03 remote unit).
- Display results @OPC and @STC conditions
- Immediate evaluation (OK/NO) of test results
- Running IVCK tests in sequence with Start&Save function

The instrument is also provided with an internal Database capable of storing up to 64 PV modules (**to be uploaded by the user**), with backlit display, internal contrast adjustment and a **HELP** key able to give valid help to the operator while connecting the instrument to the installation. An Auto Power OFF function, which can also be deactivated, is available after approx. 5 minutes

3. PREPARATION FOR USE

3.1. INITIAL CHECKS

Before shipping, the instrument has been checked from an electric as well as a mechanical point of view. All possible precautions have been taken so that the instrument is delivered undamaged. However, we recommend checking it to detect any damage possibly suffered during transport. In case anomalies are found, immediately contact the dealer. We also recommend checking that the packaging contains all components indicated in § 10.4. In case of discrepancy, please contact the Dealer. In case the instrument should be returned, please follow the instructions given in § 12

3.2. INSTRUMENT POWER SUPPLY

The instrument is powered by 6x1.5V alkaline batteries of type AA LR06 or 6 x 1.2V NiMH rechargeable batteries of type AA. The symbol “” indicates the charge level of the batteries. For battery replacement, please refer to § 9.2.

The instrument is capable of keeping data stored even without batteries.

The instrument is provided with advanced algorithms to maximize the batteries life. A long pressing of the **HELP/**  key turns on the display's backlighting. A frequent use of backlighting reduces the batteries life.

3.3. STORAGE

The instrument has been designed to be used in the environmental conditions specified in § 10.3. The presence of significantly different environmental conditions can compromise the safety of the instrument and the operator and/or not guarantee precise measurements. After a long period of storage and/or in extreme environmental conditions, before using, wait until the conditions inside the instrument should be comparable to the conditions of the environment in which it is operating.

4. NOMENCLATURE

4.1. DESCRIPTION OF THE INSTRUMENT

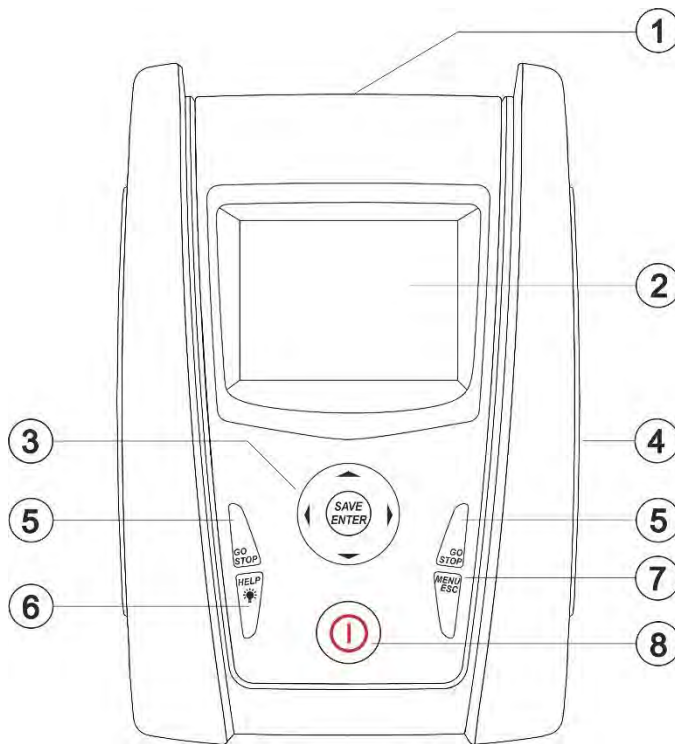

CAPTION:

1. Inputs
2. LCD display
3. Keys **▼,▲,▶,◀, SAVE/ENTER**
4. Compartment of connector for optical/USB cable
5. Key **GO/STOP**
6. Key **HELP**
7. Key **ESC/MENU**
8. Key **ON/OFF**

Fig. 1: Description of the front part of the instrument



CAPTION:

1. **P, N** inputs for DC voltage measurement (IVCK) / Insulation ($M\Omega$)
2. **E, C** inputs for continuity tests (RPE)
3. **TEMP** input for measuring module temperature with PT305 probe
4. **IRR** input for irradiance measurement with HT305 cell

Fig. 2: Description of the upper part of the instrument

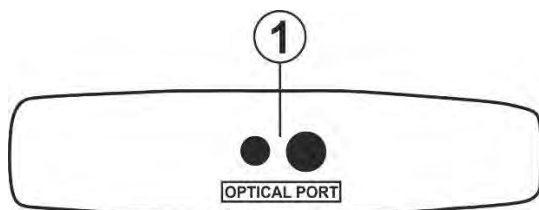

CAPTION:

1. Connector for connecting optically insulated optical/USB output cable

Fig. 3: Description of the instrument's side

4.2. KEYBOARD DESCRIPTION

The keyboard includes the following keys:



ON/OFF key to switch on/off the instrument



ESC key to exit the selected menu without confirming
MENU key to go back to the instrument's general menu at any time



Keys ◀ ▶ ▲ ▼ to move the cursor within the various screens in order to select programming parameters
SAVE/ENTER key to save internal parameters and the results of measurements (SAVE) and to select the desired functions from the menu (ENTER)



GO key to start measuring
STOP key to stop measuring



HELP key to access the help on line and display, for each selected function, possible connections between the instrument and the system
 Key  (**long pressing**) to adjust the display's backlight

4.3. INITIAL SCREEN

When switching on the instrument, the initial screen appears for a few seconds. It shows:

- The instrument model (PVCHECKS-ONE)
- The manufacturer's name
- The serial number (SN:) of the instrument
- The hardware (HW) and firmware (FW) version of the two PCBs present in the instrument's memory
- The date of the last instrument calibration (Calibration date:)

PVCHECKS-ONE

HT ITALIA

SN: 26060002

FWCPU: 1.00 FWMIS: 1.00

HWCPU: 00 HWMIS: 00

Calibration date:

14/03/2026

After a few seconds, the instrument switches to the last function selected.

5. GENERAL MENU

Pressing the **ESC** key in any condition of the instrument allows going back to the general menu, in which internal parameters may be set and the desired measuring function may be selected. Use the cursor to select one of the options and confirm with **ENTER** to access the desired function.

MENU	15/03 – 18:04	MENU	15/03 – 18:04
DMM	: Multimeter	DB	: PVMod.Database
UREM	: Remote Unit	SET	: Settings
IVCK	: PVTest Sequence	MEM	: Data saved
OPT	: Optimizer	PC	: Data transfer
MΩ	: Insulation		
GFL	: Find INS fault		
RPE	: Continuity		
	▼		▼

5.1. SET – INSTRUMENT SETTINGS

Move the cursor to **SET** by using the arrow keys (▲, ▼) and confirm with **ENTER**. The instrument shows the screen which allows access to internal settings. Settings will be maintained also after switching off the instrument.

SET	15/10 – 18:04
Language	
Date/Time	
General settings	
Irrad. & Temperature	
Information	
Operator name	

5.1.1. Language

Move the cursor to **Language** by using the arrow keys (▲, ▼) and confirm with **ENTER**. The instrument shows the screen which allows setting the system language. Select the desired option by using the arrow keys (▲, ▼). Press the **ENTER** key to confirm or the **ESC** key to go back to the previous screen.

SET	15/10 – 18:04
English	
Italiano	
Español	
Deutsch	
Français	
Portuguese	

5.1.2. Date/Time

Move the cursor to **Date/Time** by using the arrow keys (▲, ▼) and confirm with **ENTER**. Subsequently, the screen to the side appears, so that the system's date/time can be set. Select "Format" to set the European ("DD/MM/YY, hh:mm" **EU**) or American ("MM/DD/YY hh:mm" **USA**) format. Select the desired option by using the arrow keys (▲, ▼) and (◀, ▶). Press the **ENTER** key to confirm or the **ESC** key to go back to the previous screen.

SET	15/10 – 18:04	
Format	: ◀ EU ▶	
Year	: ◀ 19 ▶	
Month	: ◀ 10 ▶	
Day	: ◀ 14 ▶	
Hour	: ◀ 17 ▶	
Minute	: ◀ 38 ▶	

5.1.3. General settings

Move the cursor to **General settings** by using the arrow keys (▲, ▼) and confirm with **ENTER**. The instrument shows the screen in which it is possible to enable/disable the auto power off function, key sound, display contrast and WiFi connection (see § 8). Select the desired option by using the arrow keys (▲, ▼). Press the **ENTER** key to confirm or the **ESC** key to go back to the previous screen.

SET	15/10 – 18:04	
AutoPowerOff	: ◀ OFF ▶	
Keys Sound	: ◀ OFF ▶	
Contrast	: ◀ 50 ▶	
WiFi	: ◀ OFF ▶	

5.1.4. Irradiance & Temperature

This section allows setting irradiance measurement type and the minimum irradiance threshold for IVCK measurement (see § 6.8)

1. Position the cursor onto "**Irrad. & Temperature**" by using the arrow keys (▲, ▼) and confirm with **ENTER**.
2. The "**Irr. & Temp.**" item allows the selection of the following options:
 - **OFF** → The IVCK test is performed **without considering any irradiation value**, neither with direct connection to the HT305 cell instrument, nor with connection of the HT305 cell to the SOLAR03 remote unit
 - **Direct** → The IVCK test is performed with irradiance measurement by connecting the HT305 cell **directly to the "IRR" input** (see Fig. 2 – part 4) of the instrument. In this case, the serial number of the connected and recognized HT305 cell is displayed. If the cell is not connected or recognized, the "- -" symbol is shown on the display. The **TEMP** input is also enabled for measuring the module temperature (also settable in the other modes provided: AUTO, MAN)

SET	15/10 – 18:04	
Irr. & Temp.	: ◀ Direct ▶	
Min.Irrad.[W/m2]	: ◀ 700 ▶	
HT305 SN	: 25020000	
Data saved		



CAUTION

The "Direct" measurement is valid **ONLY for Monofacial modules**

- **R. Unit** → the IVCK test is performed with irradiation measurement with HT305 cell/cells **connected to the SOLAR-03 remote unit**

- Position the cursor onto item “**Min. Irrad. [W/m²]**” by using the arrow keys (▲, ▼) and confirm with **ENTER**. The display shows the screen containing, which allows setting the minimum irradiance threshold expressed in W/m², used as a reference for IVCK measurement. To set the minimum irradiance threshold, use the arrow keys (◀, ▶). The value can be set in a range **100 ÷ 1000 W/m²** in steps of **10 W/m²**



CAUTION

The “**Remote Unit**” item in the general menu is **only** present with the “**R. Unit**” option selected

- Press the **SAVE** key to save the settings made; the message “Data saved” will be displayed for a few seconds. Press the **ESC/MENU** key to exit without saving and go back to the previous screen.

5.1.5. Information

Move the cursor to **Info** by using the arrow keys (▲, ▼) and confirm with **ENTER**.

The instrument shows the initial screen as indicated in the screen to the side. Press the **ESC** key to go back to the main menu.



5.1.6. Operator name

This option allows to include the name of the operator who carried out the measurements using the instrument (**max 12 digits**). The chosen name will be included in the reports created by using the management software.

- Use the arrow keys ◀ or ▶ to move the cursor to the selected digit and press the **SAVE/ENTER** key to enter.
- Move the cursor to “DEL” and press the **SAVE/ENTER** key to delete the selected digit.
- Move the cursor to “OK” and press the **SAVE/ENTER** key to confirm the written name and go back to the previous screen.

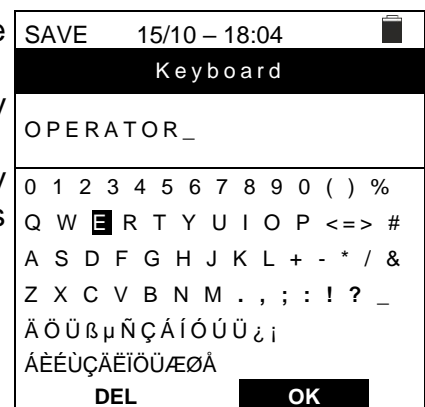

6. OPERATING INSTRUCTIONS

6.1. DMM – MULTIMETER FUNCTION

In this function, the instrument shows the RMS (root mean square) and DC (average) values of voltages between the positive (+) and negative (-) pole, between the positive (+) pole and earth connection (PE) and between the negative (-) pole and earth connection (PE), in order to check for the presence of AC components on input voltages.

1. Position the cursor onto **DMM** by using the arrow keys (**▲**, **▼**) and confirm with **ENTER**. The display shows the screen to the side.

DMM	15/10 – 18:04	
VPNrms	0	V
VPErms	0	V
VNERms	0	V
VPNdc	0	V
VPEdc	0	V
VNEdc	0	V

2. Connect the instrument to the PV string to be tested as shown in Fig. 4.

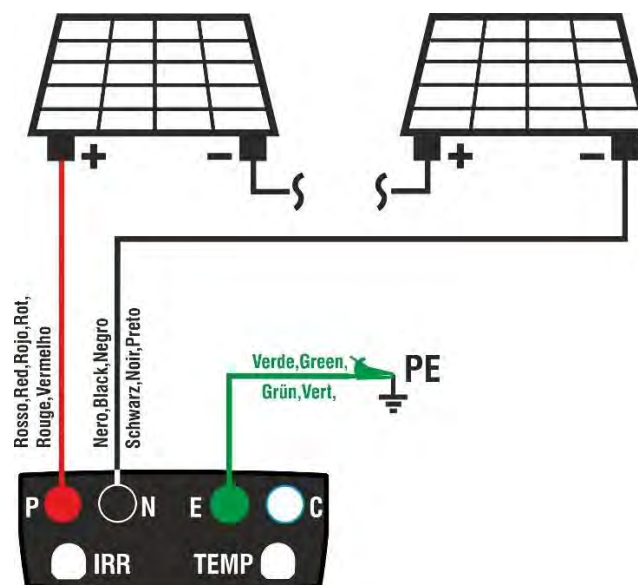

Fig. 4: Instrument connection for DMM Function

3. The voltage values are shown on the display as illustrated in the screen to the side.

DMM	15/10 – 18:04	
VPNrms	980	V
VPErms	490	V
VNERms	748	V
VPNdc	980	V
VPEdc	490	V
VNEdc	-490	V



CAUTION

The results of function DMM cannot be saved in the instrument's memory.

6.2. UREM – REMOTE UNIT

The SOLAR03 remote unit allows measuring the Irradiance and temperature values of the module, which are indispensable for the evaluation of the I-V curve, as well as the IVCK with values referenced to @STC. In general, the instrument and the SOLAR03 unit can operate in **direct connection** or **recording**.



CAUTION

- The maximum direct connection distance between the SOLAR03 unit and the instrument can be depending on the obstacles between the two units and is **up to 100m (328ft) in free air conditions**
- The maximum distance for direct connection **is indicative** as it is strongly influenced by many uncontrollable external variables. **The recommended measurement mode is always that of recording** (see § 6.8.5) which does not require an active Bluetooth connection during measurements and, regardless of the obstacles present and the extension of the field to be measured, **guarantees a reliable measurement in every situation**

This section manages all operations which can be performed by using the remote unit SOLAR03, which can also be used for IVCK measurements. In particular, it is possible to:

- **Through Bluetooth connection**, search for a remote unit **SOLAR03**, which can be managed by the instrument, adding it to the instrument's internal list (**max 5 remote units**)



CAUTION

The indicative maximum communication distance via Bluetooth (up to 100m/328ft) refers to an open field, dry environment, 1m (3ft) from the ground, in the absence of obstacles and possible electromagnetic disturbances deriving from other sources close to the instruments

- Select or cancel a remote unit SOLAR03 among those present in the list;
- Pair a remote unit SOLAR03 to/from the instrument so that it can be automatically recognized upon every connection;
- Display the information of the selected remote unit.
- Activate/stop the **recording** of environmental parameters (irradiation/temperature) on an active and connected remote unit (see § 6.8.5)

In particular, for each managed remote unit SOLAR03, the instrument displays:

- Serial number
- Item "Act" → active (symbol "✓") or inactive (no symbol) remote unit
- Item "Stat." → active connected (symbol "ⓘ") or active disconnected (symbol " ⓘ ") remote unit
- Item "Rec" → active and connected unit currently recording (symbol "Ⓜ")

To associate a **new** remote unit SOLAR03 to the instrument, proceed as follows:

1. Position the cursor onto **UREM** by using the arrow keys (▲,▼) and confirm with **ENTER**
2. Use the arrow keys ◀ or ▶ to select item “**Find**” to start searching for a remote unit SOLAR03. The message “**Please wait...**” is shown on the display.

UREM 15/10 – 18:04				
SOLAR03	Act.	Stat.	Rec	
Please wait...				
Find	Pair	Info	Start	

3. The instrument **activates the Bluetooth connection** and shows the screen to the side for a few seconds, searching for a remote unit SOLAR03

UREM 15/10 – 18:04				
SOLAR03	Act.	Stat.	Rec	
SOLAR03 SN: - - -				
Find Remote Unit				

4. On the remote unit SOLAR03, activate “**Pairing**” (refer to user manual of remote unit SOLAR03), so that it can be recognized by the instrument. Once done, the serial number of the remote unit and the message “**Remote unit detected. Pair? (ENTER/ESC)**” appear on the display as shown in the screen to the side.

UREM 15/10 – 18:04				
SOLAR03	Act	Stat.	Rec	
SOLAR03 SN: 23051203				
Remote Unit detected associate? (ENTER/ESC)				

5. **Confirm with ENTER on the instrument and on the remote unit SOLAR03 for pairing.** From now on, the instrument and the remote unit are paired and it will not be necessary to repeat these operations. To connect the instrument to the remote unit, it will be sufficient to switch them on, bring them near to each other and wait for pairing.

UREM 15/10 – 18:04				
SOLAR03	Act	Stat.	Rec	
23051203	√	(↑↓)		
U.Rem. Connected				
Find	Unpair	Info	Start	

6. To start recording on an active and connected remote unit, use the arrow keys ◀ or ▶ and select “**Start**””. The symbol “**Ⓢ**” will subsequently appear.

UREM 15/10 – 18:04			
SOLAR03	Act	Stat.	Rec
23051203	√	((↑))	
U. Rem. Connected			
Find	UnPair	Info	Start

In case the instrument has previously been associated to two or more remote units, to switch from a remote unit to another:

7. Use the arrow keys ◀ or ▶ and select “**Unpair**” and confirm with **ENTER** to unpair the current remote unit. To carry out this operation, it is not necessary that the currently associated remote unit is also connected to the instrument.
8. Use the arrow keys (▲, ▼) to select the new remote unit. The new unit must be switched on and be located within the connection range of the instrument.
9. Use the arrow keys ◀ or ▶ and select “**Pair**” and confirm with **ENTER** to connect the remote unit to the instrument.
10. The previously unpaired unit can also be deleted from the list using “**DEL**”

UREM 15/10 – 18:04			
SOLAR03	Act	Stat.	Rec
23051203	√	((↑))	
23061215		I	
U. Rem. Connected			
Find	Unpair	Info	Start

11. Use the arrow keys ◀ or ▶ to select “**Info**” to display the following information on the active and connected remote unit SOLAR03:
 - Model
 - Serial Number
 - Internal FW and HW version
 - Status of possible ongoing recording
 - Residual memory available for recordings
 - Status of internal battery

UREM 15/10 – 18:04	
Remote unit	
SOLAR03	
HT ITALIA	
SN:	23051203
HW:	1.02
FW:	1.07
Status:	No Rec.
Free mem.:	0g, 2h
Battery:	53%

6.3. RPE – CONTINUITY MEASUREMENT ON PV MODULES/STRINGS/FIELDS

The purpose of this measurement is performing a continuity test of the protective and equipotential conductors (e.g.: from rod to earth and connected foreign earth) and earth rods of SPDs on PV installations. The test must be carried out using a test current > 200mA in compliance with standards IEC/EN62446-1 and IEC/EN61557-4.



CAUTION

We recommend a preliminary check of correct functioning of the instrument before carrying out a measurement by shorting input terminals **E** and **C**, checking an almost zero continuity value and an out-of-scale value with terminals E and C open

6.3.1. Calibration of measuring cables

1. Position the cursor onto **RPE** by using the arrow keys (**▲**, **▼**) and confirm with **ENTER**. The display shows the following screen:

RPE	15/10 – 18:04		
R	- - -	Ω	
I _{test}	- - -	mA	
STD	2.00Ω	- - - Ω	
MODE	Lim.		>φ<

2. Connect the measuring cables to each other as shown in Fig. 5.

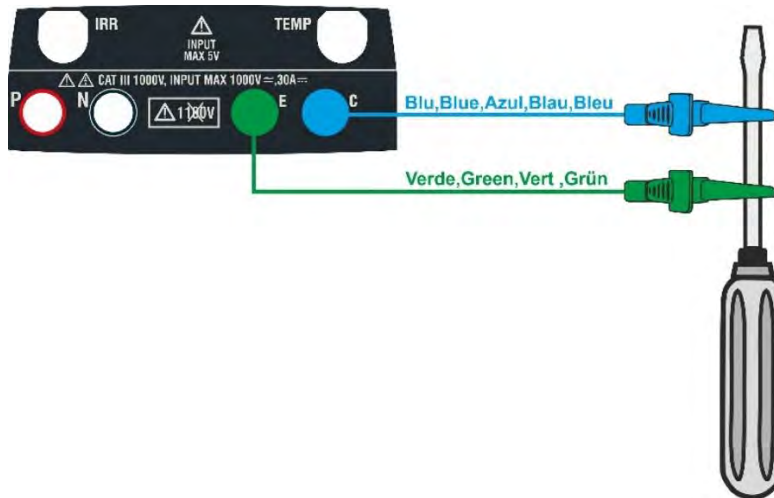

Fig. 5: Compensation of the measuring cables resistance

3. Use the arrow keys **◀** or **▶** and select the position “>φ<”. The display shows the screen to the side.

RPE	15/10 – 18:04		
R	- - -	Ω	
I _{test}	- - -	mA	
STD	2.00Ω	- - - Ω	
MODE	Lim.		>φ<

4. Press the **GO/STOP** key to start calibration. Messages “**Measuring...**” followed by “**Verification**” and “**Zeroing**” are shown in a sequence on the display.

RPE		15/10 – 18:04		
R	- - -	Ω		
I _{test}	- - -	mA		
Measuring...				
STD	2.00 Ω	- - -	Ω	
MODE	Lim.			> ϕ <

5. At the end of the compensation procedure, in case the measured resistance value is $\leq 5\Omega$, the instrument emits a double tone to signal the positive result of the test and displays the value of the compensated resistance of the cables, which will be subtracted from all the subsequent continuity measurements, at the bottom on the right side of the display.

RPE		15/10 – 18:04		
R	- - -	Ω		
I _{test}	- - -	mA		
STD	2.00 Ω		0.06 Ω	
MODE	Lim.			> ϕ <

6.3.2. Carrying out continuity measurements in Standard (STD) mode

1. Position the cursor onto **RPE** by using the arrow keys (**▲**, **▼**) and confirm with **ENTER**. The display shows the following screen. The symbol “STD” is shown on the display.

RPE	15/10 – 18:04		
R	- - -	Ω	
Itest	- - -	mA	
STD	2.00Ω	- - - Ω	
MODE	Lim.		>φ<

2. Use the arrow keys **◀** or **▶** and select the position “**Lim.**”. The display shows the screen to the side.
3. Use the arrow keys (**▲**, **▼**) to set the limit reference threshold for continuity measurement, which can be selected in a range between **0.01Ω ÷ 9.99Ω** in steps of 0.01Ω (please remember that standard IEC/EN62446-1 does not establish a limit value for resistance and typical values are approx. 1Ω or 2Ω).

RPE	15/10 – 18:04		
R	- - -	Ω	
Itest	- - -	mA	
STD	2.00Ω	- - - Ω	
MODE	Lim.		>φ<

4. Carry out the initial calibration of the measuring cables (see § 6.3.1).
5. Connect the instrument to the PV module/string being tested and to the main earth node of the system as shown in Fig. 6.

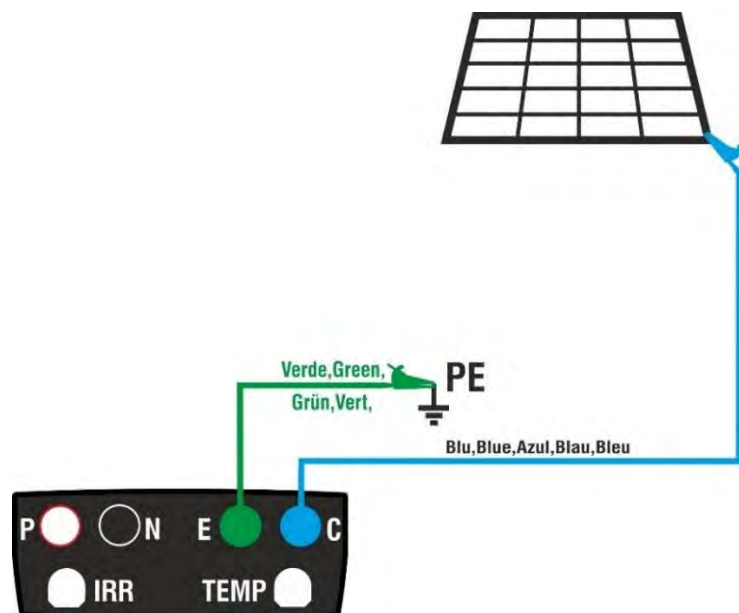



Fig. 6: Connection of instrument for continuity test on structures of the PV installation



CAUTION

Upon pressing the **GO/STOP** key, different error messages can be displayed by the instrument (§ 6.3.4) and, therefore, the test cannot be started. Check and eliminate, if possible, the problem causing the error message before going on with the test.

6. Press the GO/STOP key to start the test. In case no error conditions occur, the instrument displays the message “Measuring...” as shown in the screen to the side.

RPE	15/10 – 18:04		
R	- - -	Ω	
I _{test}	- - -	mA	
Measuring...			
STD	2.00 Ω	0.06 Ω	
MODE	Lim.		> ϕ <

7. At the end of measurement, the instrument provides the value of resistance of the object being tested. If the result is lower than the set maximum limit value, the instrument shows the message “OK” (value lower or equal to the set limit threshold), otherwise it displays the message “NO OK” (value higher than the set limit threshold) as shown in the screen to the side.
8. Press the **SAVE** key to store the test result in the instrument’s memory (see § 7.1) or the **ESC/MENU** key to exit the screen without saving and go back to the main measuring screen.

RPE	15/10 – 18:04		
R	0.23	Ω	
I _{test}	210	mA	
OK			
STD	2.00 Ω	0.06 Ω	
MODE	Lim.		> ϕ <

6.3.3. Carrying out continuity measurements in Timer (TMR) mode

1. Position the cursor onto **RPE** by using the arrow keys (**▲**,**▼**) and confirm with **ENTER**. The display shows the following screen.
2. Use the arrow keys (**▲**,**▼**) to select the Timer mode. The symbol “TMR” is shown on the display.

RPE	15/10 – 18:04			
R	- - -		Ω	
I _{test}	- - -		mA	
T	- - -		s	
TMR	2.00 Ω	12s	- - - Ω	
MODE	Lim.	Time	> ϕ <	

3. Use the arrow keys **◀** or **▶** and select the position “**Lim.**”. The display shows the screen to the side.
4. Use the arrow keys (**▲**,**▼**) to set the limit reference threshold for continuity measurement, which can be selected in a range between **0.01 Ω ÷ 9.99 Ω** in steps of 0.01 Ω (please remember that standard IEC/EN62446-1 does not establish a limit value for resistance and typical values are approx. 1 Ω or 2 Ω).

RPE	15/10 – 18:04			
R	- - -		Ω	
I _{test}	- - -		mA	
T	- - -		s	
TMR	2.00 Ω	12s	- - - Ω	
MODE	Lim.	Time	> ϕ <	

5. Use the arrow keys **◀** or **▶** and select the position “**Time**”. The display shows the screen to the side.
6. Use the arrow keys (**▲**,**▼**) to set the **duration of continuity measurement (Timer)**, which can be selected in a range between **3s ÷ 99s in steps of 3s**.

RPE	15/10 – 18:04			
R	- - -		Ω	
I _{test}	- - -		mA	
T	- - -		s	
TMR	2.00 Ω	12s	- - - Ω	
MODE	Lim.	Time	> ϕ <	

7. Carry out the initial calibration of the measuring cables (see § 6.3.1).
8. Connect the instrument to the PV module/string being tested and to the main earth node of the system as shown in Fig. 6.



CAUTION

Upon pressing the **GO/STOP** key, different error messages can be displayed by the instrument (§ 6.3.4) and, therefore, the test cannot be started. Check and eliminate, if possible, the problem causing the error message before going on with the test.

9. Press the **GO/STOP** key to start the test. In case no error conditions occur, the instrument starts a series of continuous measurements for the entire duration of the set Timer, **emitting a short sound every 3s**, and showing alternatively the messages “**Measuring...**” and “**Please wait...**” as shown in the screen to the side. In this way, the operator can move from one point to another of the place in which measurement is being carried out. During the “**Please wait**” message it is possible to move from one point to another

RPE	15/10 – 18:04			
R	0.23	Ω		
I _{test}	209	mA		
T	11	S		
Please wait...				
TMR	2.00 Ω	12s	0.06 Ω	
MODE	Lim.	Time	> ϕ <	

10. At the end of measurement, the instrument provides the maximum value among all those of the partial measurements carried out. If the result is lower than the set maximum limit value, the instrument shows the message “**OK**” (value lower or equal to the set limit threshold), otherwise it displays the message “**NO OK**” (value higher than the set limit threshold) as shown in the screen to the side.

RPE	15/10 – 18:04			
R	0.54	Ω		
I _{test}	209	mA		
T	0	S		
OK				
TMR	2.00 Ω	12s	0.06 Ω	
MODE	Lim.	Time	> ϕ <	

11. Press the **SAVE** key to store the test result in the instrument’s memory (see § 7.1) or the **ESC/MENU** key to exit the screen without saving and go back to the main measuring screen.

6.3.4. Anomalous situations

1. To zero the value of compensated resistance, carry out a new compensation procedure with a resistance higher than 5Ω as, for example, with open leads. The message “Zero reset” appears on the display.
2. In case the instrument detects a voltage **higher than 3V** at its terminals E and C, it does not carry out the test, gives out a long sound and displays the message “V.Input > 3V”.
3. In case the instrument detects that the calibrated resistance is higher than the measured resistance, the instrument gives out a long sound and displays the message: “Zeroing NOT OK”
4. In case the instrument detects a resistance higher than 5Ω at its terminals, it gives out a long sound, zeroes the compensated value and displays the message “Zero reset”.
5. In case it was detected that the calibrated resistance is higher than the measured resistance (for example because cables different from the provided ones were used), the instrument gives a long acoustic signal and displays a screen similar to the one to the side. Carry out a reset and make a new compensation of the cables.

RPE	15/10 – 18:04		
R	- - -	Ω	
Itest	- - -	mA	
Zero reset			
STD	2.00 Ω	- - - Ω	
MODE	Lim.		> ϕ <

RPE	15/10 – 18:04		
R	- - -	Ω	
Itest	- - -	mA	
V.Input > 3V			
STD	2.00 Ω	- - - Ω	
MODE	Lim.		> ϕ <

RPE	15/10 – 18:04		
R	0.03	Ω	
Itest	212	mA	
Zeroing NOT OK			
STD	2.00 Ω	0.220 Ω	
MODE	Lim.		> ϕ <

RPE	15/10 – 18:04		
R	> 4.99	Ω	
Itest	49	mA	
Zero reset			
STD	2.00 Ω	- - - Ω	
MODE	Lim.		> ϕ <

RPE	15/10 – 18:04		
R	- - -	Ω	
Itest	- - -	mA	
Rcal > Rmeas			
STD	2.00 Ω	- - - Ω	
MODE	Lim.		> ϕ <

6.4. $M\Omega$ – MEASUREMENT OF INSULATION ON PV MODULES/STRINGS/FIELDS

The purpose of this function is measuring the insulation resistance of the active conductors of PV modules, strings and fields according to the prescriptions of standards IEC/EN62446-1 and IEC/EN61557-2, **with no need to use an external switch to short-circuit the positive and negative terminals** (see § 11.4)



CAUTION

- **DO NOT use this function to perform insulation measurements on PV strings or modules that integrate MLPE devices** (microinverters, power optimizers, or rapid shutdown devices – RSD). Performing insulation tests on such configurations may result in **damage to both the MLPE devices and the instrument**. **Refer to the “OPT” mode (see § 6.6) to manage such situations**
- Do not touch the masses of the modules during the measurement as they could be at dangerous potential even with the system disconnected due to the voltage generated by the instrument
- The measurement could give incorrect results if the earth reference is not correctly connected to input **E**
- We recommend a preliminary check of correct functioning of the instrument before carrying out a measurement, **setting the TMR function** by short-circuiting the **N** and **E** terminals, verifying an almost zero insulation value and an out-of-scale value with open **N** and **E** terminals



CAUTION

- **Insulation measurement can be performed on a single module, string or on an installation consisting in more strings connected in parallel.**
- Separate the string/installation from the inverter and from possible overvoltage protections.
- If the module/string has a pole connected to earth, this connection must be temporarily interrupted.
- Standard IEC/EN62446-1 sets $1M\Omega$ as a minimum value of insulation resistance for installations with a rated voltage higher than 120V.
- We recommend measuring insulation directly on the module/string/field located upstream of possible blocking diodes.

The instrument measures insulation in the following modes:

- **DUAL** mode → the instrument measures insulation in a sequence between the positive pole (+) and the PE reference and between the negative pole (-) and the PE reference of PV modules, strings or fields, and calculates overall parallel resistance R_p
- **TMR** mode → the instrument measures continuously (with a max duration of 999s) between terminal “N” and the PE reference, displaying the minimum value obtained of the **parallel resistance between the (+) and (-) poles** of strings/modules or a generic insulation resistance of **non-live cables** obtained at the end of the selected time. In this way, the instrument also calculates the DAR (Dielectric Absorption Ratio) and PI (Polarization Index) parameters, if the duration of the test is suitable for these parameters' calculation

6.4.1. Measuring insulation – DUAL mode

1. Position the cursor onto **MΩ** by using the arrow keys (**▲**, **▼**) and confirm with **ENTER**. The display shows the screen to the side. By using the arrow keys (**▲**, **▼**) again, select the “**DUAL**” measuring mode, in position “**MODE**”.

MΩ	15/10 – 18:04		
	(+)	(-)	
Vtest	- - -	- - -	V
Riso	- - -	- - -	MΩ
	Rp	- - -	MΩ
	VPN	VPE	VNE
	0V	0V	0V
DUAL	1000V	1.00MΩ	
MODE	Vtest.	Lim.	

2. Use the arrow keys **◀** or **▶** and select the position “**Vtest**” to set the test voltage.
3. Use the arrow keys (**▲**, **▼**) to select one of the following test voltages (Vnom): **250, 500, 1000VDC**. Please remember that, in compliance with standard IEC/EN 62446-1, test voltage Vtest must be \geq rated voltage of the installation.

MΩ	15/10 – 18:04		
	(+)	(-)	
Vtest	- - -	- - -	V
Riso	- - -	- - -	MΩ
	Rp	- - -	MΩ
	VPN	VPE	VNE
	0V	0V	0V
DUAL	1000V	1.00MΩ	
MODE	Vtest.	Lim.	

4. Use the arrow keys **◀** or **▶** and select the position “**Lim.**”.
5. Use the arrow keys (**▲**, **▼**) to set the **minimum** limit threshold for insulation measurement, which can be selected among the values **0.05, 0.10, 0.23, 0.25, 0.50, 1.00, 50MΩ**. Please remember that standard IEC/EN62446-1 sets 1MΩ as a minimum value of insulation resistance for installations with a rated voltage higher than 120V.

MΩ	15/10 – 18:04		
	(+)	(-)	
Vtest	- - -	- - -	V
Riso	- - -	- - -	MΩ
	Rp	- - -	MΩ
	VPN	VPE	VNE
	0V	0V	0V
DUAL	1000V	1.00MΩ	
MODE	Vtest.	Lim.	

6. Connect the instrument to the PV string to be tested as shown in Fig. 7. **The test can be carried out also on more strings connected in parallel to each other. Please remember that it is also necessary to separate possible overvoltage protections connected to the cables of the string(s) and that it is recommended to measure upstream of possible blocking diodes.**

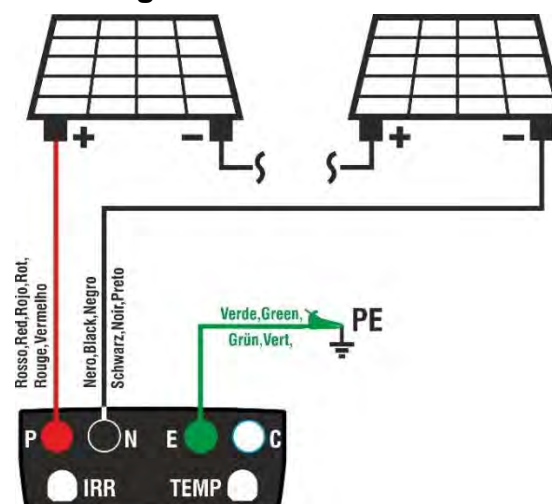

Fig. 7: Instrument connection for insulation measurement in DUAL mode



CAUTION

Upon pressing the **GO/STOP** key, different error messages can be displayed by the instrument (§ 6.4.3) and, therefore, the test cannot be started. Check and eliminate, if possible, the problem before going on with the test

7. **Press and hold the GO/STOP key for at least 3s** in order to start the test. In case no error conditions occur, the instrument displays the message **“Measuring...”** as shown in the screen to the side. In field “Vtest”, the real test voltage generated by the instrument is shown. **Test duration may vary according to the presence of stray capacitances**

MΩ	15/10 – 18:04		■
	(+)	(-)	
Vtest	- - -	- - -	V
Riso	- - -	- - -	MΩ
	Rp	- - -	MΩ
	VPN	VPE	VNE
	980V	490V	-490V
Measuring...			
DUAL	1000V	1.00MΩ	
MODE	Vtest.	Lim.	

8. The instrument carries out the following measurements in a sequence:
 - Insulation between positive pole (+) of the string and earth connection
 - Insulation between negative pole (-) of the string and earth connection
 - Calculation of the value of resistance **Rp** given by the parallel of measurements (+) and (-)

MΩ	15/10 – 18:04		■
	(+)	(-)	
Vtest	1010	1015	V
Riso	>100	>100	MΩ
	Rp	>100	MΩ
	VPN	VPE	VNE
	980V	490V	-490V
OK			
DUAL	1000V	1.00MΩ	
MODE	Vtest.	Lim.	

If **“Rp ≥ Lim”**, the instrument shows the message **“OK”**, to indicate a **positive** result of measurement. Press the **SAVE** key to store the test result in the instrument’s memory (see § 7.1) or the **ESC/MENU** key to exit the screen without saving and go back to the main measuring screen.

6.4.2. Measuring insulation – TMR mode

1. Position the cursor onto **MΩ** by using the arrow keys (▲, ▼) and confirm with **ENTER**. The display shows the screen to the side. By using the arrow keys (▲, ▼) again, select the **“TMR”** measuring mode, in position **“MODE”**.
2. Use the arrow keys ◀ or ▶ and select the position **“Vtest”** to set the test voltage.
3. Use the arrow keys (▲, ▼) to select one of the following test voltages (Vnom): **250, 500, 1000VDC**. Please remember that, in compliance with standard IEC/EN 62446-1, test voltage Vtest must be ≥ rated voltage of the installation.

MΩ	15/10 – 18:04		■
Vtest(-)	- - -	- - -	V
Ri(-)	- - -	- - -	MΩ
Time	- - -	- - -	s
DAR	- - -	PI	- - -
	VPN	VPE	VNE
	---V	---V	0V
TMR	1000V	1.00MΩ	3s
MODE	Vtest.	Lim.	Time

MΩ	15/10 – 18:04		■
Vtest(-)	- - -	- - -	V
Ri(-)	- - -	- - -	MΩ
Time	- - -	- - -	s
DAR	- - -	PI	- - -
	VPN	VPE	VNE
	---V	---V	---V
TMR	1000V	1.00MΩ	3s
MODE	Vtest.	Lim.	Time

4. Use the arrow keys ◀ or ▶ and select the position “Lim.”. The display shows the screen to the side.
5. Use the arrow keys (▲, ▼) to set the **minimum** limit threshold for insulation measurement, which can be selected among the values **0.05,0.10,0.23,0.25,0.50,1.00,50,100,200MΩ**. Please remember that standard IEC/EN62446-1 sets 1MΩ as a minimum value of insulation resistance for installations with a rated voltage higher than 120V.
6. Use the arrow keys ◀ or ▶ and select the position “Time”. The display shows the screen to the side.
7. Use the arrow keys (▲, ▼) to set the measuring time in the range: **3s ÷ 999s**

MΩ	15/10 – 18:04		
Vtest(-)	- - -	V	
Ri(-)	- - -	MΩ	
Time	- - -	s	
DAR	- - -	PI	- - -
	VPN	VPE	VNE
	---V	---V	0V
TMR	1000V	1.00MΩ	3s
MODE	Vtest.	Lim.	Time

MΩ	15/10 – 18:04		
Vtest(-)	- - -	V	
Ri(-)	- - -	MΩ	
Time	- - -	s	
DAR	- - -	PI	- - -
	VPN	VPE	VNE
	---V	---V	0V
TMR	1000V	1.00MΩ	3s
MODE	Vtest.	Lim.	Time

8. Connect the instrument to the PV string to be tested as shown in Fig. 8. **The test can be carried out also on more strings connected in parallel to each other. Please remember that it is also necessary to separate possible overvoltage protections connected to the cables of the string(s) and that it is recommended to measure upstream of possible blocking diodes.**

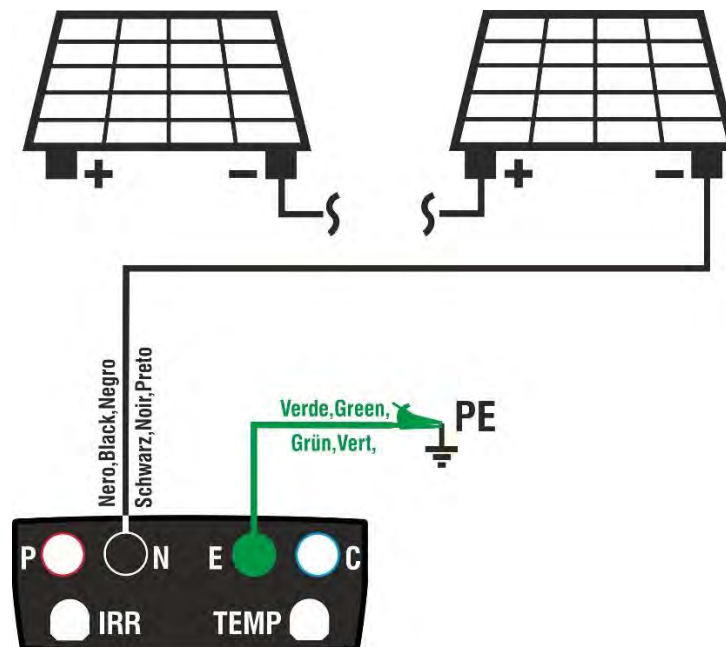

Fig. 8: Instrument connection for insulation measurement in TMR mode

CAUTION



Upon pressing the **GO/STOP** key, different error messages can be displayed by the instrument (§ 6.4.3) and, therefore, the test cannot be started. Check and eliminate, if possible, the problem causing the error message before going on with the test.

9. **Press and hold the GO/STOP key for at least 3s** in order to start the test. In case no error conditions occur, the instrument displays the message **“Measuring...”** as shown in the screen to the side. In field “Vtest (-)”, the real test voltage generated by the instrument is shown.

MΩ	15/10 – 18:04		
Vtest(-)	- - -	V	
Ri(-)	- - -	MΩ	
Time	- - -	s	
DAR	- - -	PI	- - -
	VPN	VPE	VNE
	---V	---V	- 632V
Measuring...			
TMR	1000V	1.00MΩ	700s
MODE	Vtest.	Lim.	Time

10. If **“Ri(-) ≥ Lim”**, the instrument shows the message **“OK”** to indicate the **positive** result of measurement.
If the measuring time is $\geq 60s$, the instrument shows on the display the value of parameter **DAR** ((Dielectric Absorption Ratio) (see § 11.2).
If the measuring time is $\geq 600s$, the instrument shows on the display both the value of parameter **DAR** ((Dielectric Absorption Ratio) and the value of parameter **PI** (Polarization Index) (see § 11.1).

MΩ	15/10 – 18:04		
Vtest(-)	1040	V	
Ri(-)	>100	MΩ	
Time	600	s	
DAR	1.41	PI	1.02
	VPN	VPE	VNE
	---V	---V	- 632V
OK			
TMR	1000V	1.00MΩ	700s
MODE	Vtest.	Lim.	Time

Press the **SAVE** key to store the test result in the instrument’s memory (see § 7.1) or the **ESC/MENU** key to exit the screen without saving and go back to the main measuring screen.

6.4.3. Anomalous situations

- In case the instrument detects one of the following conditions: “ $|VPN| > 1000V$ ”, “ $|VPE| > 1000V$ ” or “ $|VNE| > 1000V$ ”, it stops measuring, gives out a long sound, and the message “**V.Input > 1000VDC**” appears on the display. Check the output voltage from the PV string.

MΩ	15/10 – 18:04		
	(+)	(-)	
Vtest	- - -	- - -	V
Riso	- - -	- - -	MΩ
	Rp	- - -	MΩ
	VPN	VPE	VNE
	>1000V	500V	-500V
V.Input > 1000VDC			
DUAL	1000V	1.00MΩ	
MODE	Vtest.	Lim.	

- In DUAL mode, in case the instrument, upon pressing the **GO/STOP** key, detects a voltage **VPN <0V**, it stops measuring, gives out a long sound and the message **Reverse P-N**” appears on the display. Check polarity and the instrument's connections to the PV string.

MΩ	15/10 – 18:04		
	(+)	(-)	
Vtest	- - -	- - -	V
Riso	- - -	- - -	MΩ
	Rp	- - -	MΩ
	VPN	VPE	VNE
	-980V	-500V	480V
Reverse P-N			
DUAL	1000V	1.00MΩ	
MODE	Vtest.	Lim.	

- In DUAL mode, in case the instrument, upon pressing the **GO/STOP** key, detects a voltage **VPN<15V**, it stops measuring, gives out a long sound and the message “**V.Input < 15VDC**” appears on the display. Check the output voltage from the PV string, which must be $\geq 15V$.

MΩ	15/10 – 18:04		
	(+)	(-)	
Vtest	- - -	- - -	V
Riso	- - -	- - -	MΩ
	Rp	- - -	MΩ
	VPN	VPE	VNE
	10V	5V	-5V
V.Input < 15VDC			
DUAL	1000V	1.00MΩ	
MODE	Vtest.	Lim.	

- In DUAL mode, in case the instrument, upon pressing the **GO/STOP** key, detects that one of the following conditions on measured voltages:

$$\text{RMS}(VPN) - |(VPN) \text{ DC}| < 10$$

$$\text{RMS}(VPE) - |(VPE) \text{ DC}| < 10$$

$$\text{RMS}(VNE) - |(VNE) \text{ DC}| < 10$$

is not satisfied (**presence of AC components on input voltages**), it stops measuring, gives out a long sound and the message “**V.Input > 10VAC**” is shown on the display. Check that the string should be disconnected from the inverter and that the respective cables should be separated from any other auxiliary AC voltage source

MΩ	15/10 – 18:04		
	(+)	(-)	
Vtest	- - -	- - -	V
Riso	- - -	- - -	MΩ
	Rp	- - -	MΩ
	VPN	VPE	VNE
	980V	500V	-480V
V.Input > 10VAC			
DUAL	1000V	1.00MΩ	
MODE	Vtest.	Lim.	

5. In case the instrument detects that the voltage between the positive and the negative pole is higher than the set test voltage, the message “**VPN>Vtest**” appears on the display and the instrument stops the test because it does not comply with standard IEC/EN62446-1. Check the rated voltage of the installation, change the parameter Vtest, if necessary, and repeat the test.

MΩ	15/10 – 18:04			
	(+)	(-)		
Vtest	920	910	V	
Riso	- - -	- - -	MΩ	
	Rp	- - -	MΩ	
	VPN	VPE	VNE	
	980V	500V	-480V	
VPN>Vtest				
DUAL	1000V	1.00MΩ		
MODE	Vtest.	Lim.		

6. In case the instrument detects that **Rp<Lim**, the message “**NOT OK**” is shown on the display.

MΩ	15/10 – 18:04			
	(+)	(-)		
Vtest	1040	1020	V	
Riso	0.1	>100	MΩ	
	Rp	0.1	MΩ	
	VPN	VPE	VNE	
	980V	500V	-480V	
NOT OK				
DUAL	1000V	1.00MΩ		
MODE	Vtest.	Lim.		

7. In TMR mode if the instrument detects a **positive** voltage between the **N** and **E** terminals, the message “**Reverse E-N**” is shown on the display and the test is not carried out. Reverse the connections on the instrument inputs, remembering that a **negative potential must always be present on the N terminal**

MΩ	15/10 – 18:04			
Vtest(-)	- - -		V	
Ri(-)	- - -		MΩ	
Time	- - -		s	
DAR	- - -	PI	- - -	
	VPN	VPE	VNE	
	---V	---V	632V	
Reverse E-N				
TMR	1000V	1.00MΩ	700s	
MOD0	Vtest.	Lim.	Time	

8. In TMR mode if the measured VNE voltage is greater than the test voltage, the instrument shows the message “**VEN > Vtest**” when the test is activated. Select a test voltage **greater** than the measured voltage in order to perform the test correctly

MΩ	15/10 – 18:04			
Vtest(-)	- - -		V	
Ri(-)	- - -		MΩ	
Time	- - -		s	
DAR	- - -	PI	- - -	
	VPN	VPE	VNE	
	---V	---V	-632V	
VEN > Vtest				
TMR	500V	1.00MΩ	3s	
MOD0	Vtest.	Lim.	Time	

6.5. GFL – SEARCHING FOR CONDITIONS OF LOW INSULATION ON PV STRINGS

In GFL (Ground Fault Locator) function, the instrument can provide an indication about the position of a possible single fault of low insulation located in a string of the installation due, for example, to infiltrations of water or humidity in the junction boxes of PV modules. The instrument measures input voltages and, according to the unbalance between V(+) and V(-) with respect to earth, it detects the assumed position of the fault on the string. For more details see § 11.3.

CAUTION



- **DO NOT use this function on PV strings or modules that integrate MLPE devices** (microinverters, power optimizers, or rapid shutdown devices – RSDs). Performing the GFL test on such configurations may result in **damage to both the MLPE devices and the instrument (see § 11.5)**
- Do not touch the masses of the modules during the measurement as they could be at dangerous potential even with the system disconnected due to the voltage generated by the instrument
- The measurement could give incorrect results if the earth reference is not correctly connected to input **E**
- We recommend a preliminary check of correct functioning of the instrument before carrying out a measurement, setting the TMR function by short-circuiting the **N** and **E** terminals, verifying an almost zero insulation value and an out-of-scale value with open **N** and **E** terminals

CAUTION



The GFL function allows obtaining correct results **ONLY** with the following conditions:

- Test carried out **upstream of possible blocking diodes**, on a **single string** disconnected from the inverter, from possible overvoltage protections and from functional connections to earth.
- **Single fault** of low insulation located at any position in the string
- Insulation resistance of the single fault **<1.00MΩ**
- Given the random nature of these faults, **we recommend** carrying out measurements in environmental conditions similar to those in which the fault has been detected.

1. Position the cursor onto **GFL** by using the arrow keys (▲, ▼) and confirm with **ENTER**. The display shows the screen to the side. The indication “Rp” indicates the parallel of the insulation resistances of the positive (+) and negative (-) poles of the string being tested.

GFL	15/10 – 18:04		
Rp	- - -	MΩ	
VPN	VPE	VNE	
0V	0V	0V	
10	1000V	0.23MΩ	
NMOD	Vtest.	Lim.	

2. Use the arrow keys ◀ or ▶ and select the position “**NMOD**” to set the number of modules of the string being tested.
3. Use the arrow keys (▲, ▼) to select a number of modules between: **4 ÷ 60**

GFL	15/10 – 18:04		
Rp	- - -	MΩ	
VPN	VPE	VNE	
0V	0V	0V	
10	1000V	0.23MΩ	
NMOD	Vtest.	Lim.	

4. Use the arrow keys ◀ or ▶ and select the position “**Vtest**” to set the test voltage.
5. Use the arrow keys (▲, ▼) to select one of the following test voltages (Vnom): **250, 500, 1000VDC**. **In compliance with IEC/EN62446-1, we recommend setting the test voltage of the installation $V_{test} \geq V_{nom}$**

GFL	15/10 – 18:04		
Rp	- - -	MΩ	
VPN	VPE	VNE	
0V	0V	0V	
10	1000V	0.23MΩ	
NMOD	Vtest.	Lim.	

6. Use the arrow keys ◀ or ▶ and select the position “**Lim.**”.
7. Use the arrow keys (▲, ▼) to set the **minimum** limit threshold for insulation measurement, which can be selected among the following values: **0.05MΩ, 0.1MΩ, 0.23MΩ, 0.25MΩ, 0.50MΩ., 1.00MΩ**

GFL	15/10 – 18:04		
Rp	- - -	MΩ	
VPN	VPE	VNE	
0V	0V	0V	
10	1000V	0.23MΩ	
NMOD	Vtest.	Lim.	

8. Connect the instrument to the PV string to be tested as shown in Fig. 9. **Please remember that it is also necessary to separate possible overvoltage protections connected to the cables of the string, and that it is recommended to measure upstream of possible blocking diodes.**

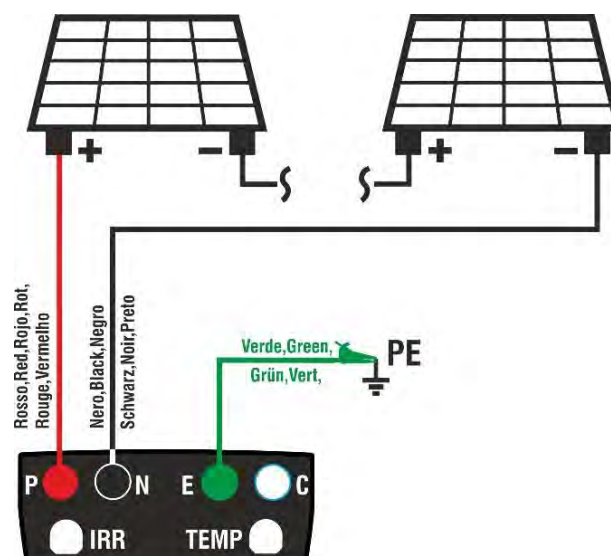

Fig. 9: Instrument connection for insulation measurement in GFL mod

CAUTION



- Upon pressing the **GO/STOP** key, different error messages can be displayed by the instrument (§ 6.4.3) and, therefore, the test cannot be started. Check and eliminate, if possible, the problem causing the error message before going on with the test
- The GFL function **must be used** only after performed the main insulation measurement (DUAL test) on modules and/or strings with negative results

9. **Press and hold the GO/STOP key for at least 3s** in order to start the test. In case no error conditions occur, the instrument displays the message “**Measuring...**” as shown in the screen to the side.

GFL 15/10 – 18:04			
R _p	- - -	MΩ	
V _{PN}	V _{PE}	V _{NE}	
0V	0V	0V	
Measuring...			
10	1000V	0.23MΩ	
NMOD	Vtest.	Lim.	

10. **With no fault conditions ($R_p \geq Lim$)**, the instrument shows the screen to the side and the message “**OK**” appears on the display.

The “OK” condition can also occur in the presence of **more than one fault** present on the string (highlighted by a failed test previously performed with the DUAL function), a condition which makes **ineffective** the GFL function

GFL 15/10 – 18:04			
R _p	> 100	MΩ	
V _{PN}	V _{PE}	V _{NE}	
980V	490V	-490V	
OK			
14	1000V	0.23MΩ	
NMOD	Vtest.	Lim.	

CAUTION



With presence of a verified fault condition, the GFL function shows:

- The position of the faulty module with tolerance **± 1 module** for **NMOD ≤ 34**
- The position of the faulty module with tolerance **± 3 modules** for **NMOD > 34**
- It is **recommended** to divide the string into sub-strings **having a lower number of modules** to obtain better test results

11. **In case a fault is present ($R_p < Lim$) in position 0 (upstream of the first module)**, the instrument shows the screen to the side and the message “**GND: Fault (+)..1 $\pm N$** ” on the display. Check the condition of the insulation of the conductor (+) which comes from the string. In the case of the figure, with NMOD=24 \rightarrow Tolerance = ± 1 , the fault can be found before or after the first module

GFL 15/10 – 18:04			
R _p	0.20	MΩ	
V _{PN}	V _{PE}	V _{NE}	
980V	970V	-10V	
GND: Fault (+)..1 ± 1			
24	1000V	0.23MΩ	
NMOD	Vtest.	Lim.	

12. **In case a fault is present ($R_p < Lim$) in position $NMOD+1$ (downstream of the last module),** the instrument shows the screen to the side and the message “**GND: Fault $NMOD..(-) \pm N$** ” on the display. Check the condition of the insulation of the conductor (-) which comes from the string. In the case of the figure, with $NMOD=24 \rightarrow$ Tolerance = ± 1 , the fault can be found before or after the last module

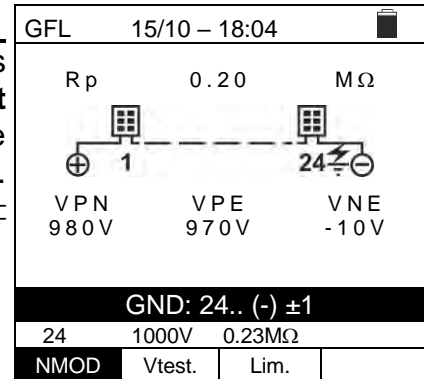

13. **In case a fault is present ($R_p < Lim$) in position 1 (between module 1 and 2),** the instrument shows the screen to the side and the message “**GND: Fault 1..2 $\pm N$** ” on the display. Check the condition of the insulation of the junction boxes of the indicated modules (1 and 2, in the example) and the relevant connection cables. In the case of the figure, having $NMOD=24 \rightarrow$ Tolerance = ± 1 , the fault can be found before the 1st module or between the 1st and 3rd module

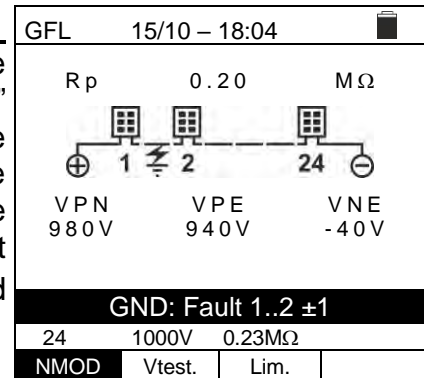

14. **In case a fault is present ($R_p < Lim$) in position $NMOD$ (between the second last and the last module),** the instrument shows the screen to the side and the message “**GND: Fault $NMOD-1..NMOD \pm N$** ” on the display. Check the condition of the insulation of the junction boxes of the indicated modules and the relevant connection cables. In the case of the figure, having $NMOD=24 \rightarrow$ Tolerance = ± 1 , the fault can be found before the 23th module and after last module

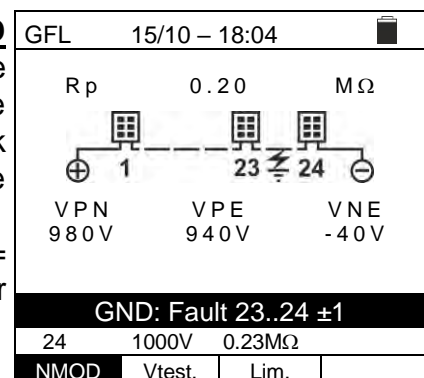

15. In case a fault is present ($R_p < Lim$) within the string, the instrument shows the screen to the side and the message (relevant to the example with $NMOD = 36$) “**GND: Fault 8..9 $\pm N$** ” on the display. Check the condition of the insulation of the junction boxes of the indicated modules and the relevant connection cables. In the case of the figure, having $NMOD=36(>35) \rightarrow$ Tolerance = ± 3 , the fault can be found between the 5th module and 12th module

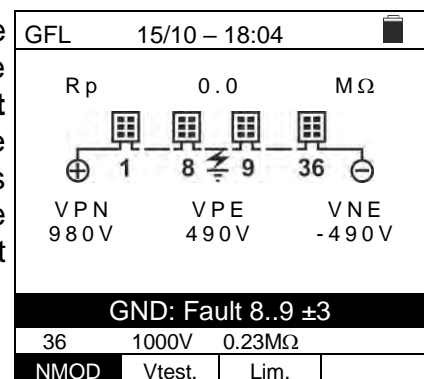

CAUTION

The results of function GFL cannot be saved in the instrument's memory.

6.6. OPT – INSULATION MEASUREMENT WITH POWER OPTIMIZERS

The purpose of this measurement is to perform insulation resistance measurements of active conductors on PV strings in compliance with requirements of the IEC/EN62446-1 and IEC/EN61557-2 guidelines **in presence of MLPE (power optimizers, rapid shutdown devices RSD) without the need to disconnect them from the PV modules** (see § 11.5)



CAUTION

- Do not touch the masses of the modules during the measurement as they could be at dangerous potential even with the system disconnected due to the voltage generated by the instrument
- The measurement could give incorrect results if the earth reference is not correctly connected to input **E**
- We recommend a preliminary check of correct functioning of the instrument before carrying out a measurement, setting the TMR function by short-circuiting the **N** and **E** terminals, verifying an almost zero insulation value and an out-of-scale value with open **N** and **E** terminals



CAUTION

- **Insulation measurement can be performed on a single module, string or on an installation consisting in more strings connected in parallel.**
- Separate the string/installation from the inverter and from possible overvoltage protections.
- If the module/string has a pole connected to earth, this connection must be temporarily interrupted.
- Standard IEC/EN62446-1 sets $1M\Omega$ as a minimum value of insulation resistance for installations with a rated voltage higher than 120V
- We recommend measuring insulation directly on the module/string/field located upstream of possible blocking diodes

The instrument performs insulation measurement with presence of optimizers in the following ways:

- **Measurements with optimizers equipped with a rapid shutdown device (RSD)** → the instrument performs the test in compliance with the US **NEC 690.12** standard, which regulates the requirements for this type of device (see § 11.5.1)
- **Measurements with optimizers NOT equipped with a rapid shutdown device (RSD)** → the instrument performs the test quite similar to the DUAL test (see § 6.4.1)

In both modes, the result is always the parameter **Rp = parallel resistance of the insulation resistances between the positive and negative poles** of the string + optimizers under test. This value is then compared with the minimum limit set on the instrument, and this comparison determines whether the test is passed or failed.



CAUTION

Always refer preliminarily to the manufacturer's technical data sheet regarding the test mode and any limitations of the MLPE device under test

6.6.1. Insulation measurement with optimizers having RSD function

1. Move the cursor on the **OPT** item using the arrow keys (**▲**, **▼**) and confirm with **ENTER**. The screen shown alongside appears on the display. The message “**Optimizer with Rapid Shutdown**” indicates that the measurement is performed on optimizers equipped with the **rapid shutdown (RSD = Rapid ShutDown) function**. The following parameters are shown:

OPT				15/10 – 18:04					
Rp				---				MΩ	
Optimizer with Rapid Shutdown									
V P N		V P E		V N E					
0V		0V		0V					
250V		0.6MΩ		10		1.0V			
VTest		RLim		OPT.N		Vlim			

- **VTest** → test voltage for insulation measurement
- **RLim** → minimum limit for insulation measurement
- **OPT.N** → number of optimizers present in the string
- **Vlim** → output voltage limit value from each optimizer
- Values of voltages VPn, VPE and VNE

2. Use the arrow keys (**▲**, **▼**) to access the setting of measurement parameters. The screen on the side appears on the display. Use the arrow keys (**◀**, **▶**) to set the values. The following options are available:

OPT				15/10 – 18:04					
Test Volt	:	◀	250	▶	V				
RLim	:	◀	0.6	▶	MΩ				
R.Shutdown	:	◀	ON	▶					
N. Optimizer	:	◀	10	▶					
Vlim	:	◀	1.0	▶	V				
▼									

- **Test Volt** → Set the test voltage for insulation measurement from the following options: **100V, 250V, 500V, 1000VDC**. **If the MLPE (optimizer) manufacturer does not specify a test voltage, it is recommended to set 100V**
- **RLim** → set the minimum reference threshold for the insulation measurement between the values: **0.25, 0.50, 0.60, 1.00, 50, 100, 200MΩ**
- **R.Shutdown** → set the type of optimizers under consideration with option: **ON (RSD function included)**
- **N. Optimizer** → set the number of optimizers present on the string being tested in the range: **1 ÷ 60**
- **Vlim** → set the output voltage value of each optimizer in the range: **0.1V ÷ 2.0V** steps of **0.1V**

3. Press **SAVE** key to save the settings
4. Disconnect the string(s) under test from the combiner box/inverter and wait **at least 30 s** (the maximum time specified by US **NEC 690.12** standard for all optimizers to be effectively in RSD activated state)
5. Connect the instrument to the output of the series of optimizers associated with the string under test as shown in Fig. 10. Specifically, connect the positive pole output from the **first optimizer** to terminal P, the negative pole output from **the last optimizer** to terminal N, and terminal E to the system's main ground reference

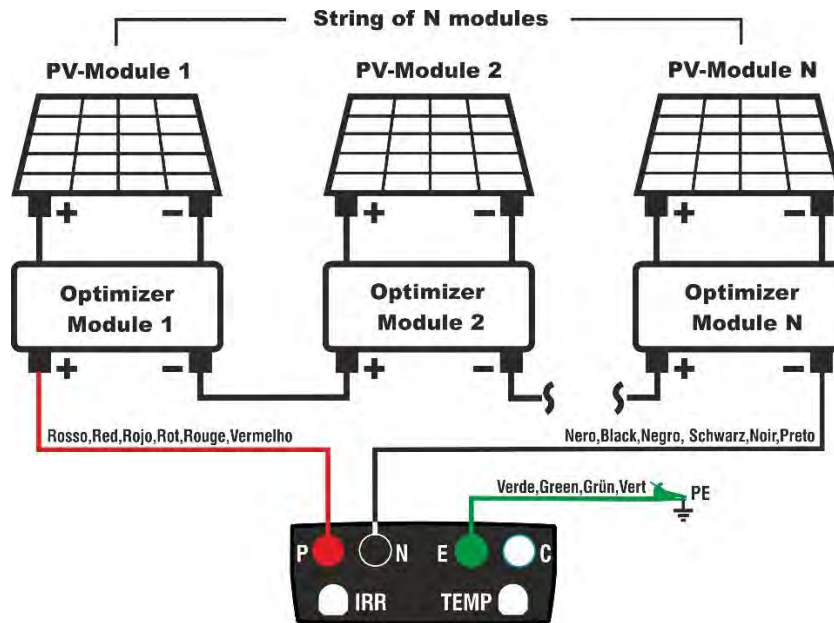

Fig. 10: Connection instrument for insulation measurement with optimizers



CAUTION

Upon pressing the **GO/STOP** key, different error messages can be displayed by the instrument (see § 6.6.3) and, therefore, the test cannot be started. Check and eliminate, if possible, the problem causing the error message before going on with the test

- Press **GO/STOP** key to activate the test. If there are no error conditions, the instrument measures the voltage between the P and N terminals between the first and last optimizer, verifying that **$V_{PN} \leq 30V$** (in accordance with **NEC 690.12 standard**) and, if so, the message "Measuring..." as shown as indicated in the screen on the side.

OPT		15/10 – 18:04	
Rp --- MΩ			
Optimizer with Rapid Shutdown			
V _{PN}	V _{PE}	V _{NE}	
10V	5V	-5V	
Measuring...			
250V	0.6MΩ	10	1.0V
V _{Test}	RLim	OPT.N	Vlim

- At the end of the measurement, the value of the insulation resistance **R_p** obtained from the **parallel resistances of the string/optimizer chain** is shown on the display. If this value is **$\geq R_{Lim}$** , the message "OK" is displayed in case of a positive test result. If this value is **$\leq R_{Lim}$** , the test has failed and the message "NOT OK" is shown on the display

OPT		15/10 – 18:04	
Rp 92 MΩ			
Optimizer with Rapid Shutdown			
V _{PN}	V _{PE}	V _{NE}	
10V	5V	-5V	
OK			
250V	0.6MΩ	10	1.0V
V _{Test}	RLim	OPT.N	Vlim



CAUTION

The results of function OPT cannot be saved in the instrument's memory

6.6.2. Insulation measurement with optimizers without RSD function

1. Move the cursor on the **OPT** item using the arrow keys (**▲**, **▼**) and confirm with **ENTER**. The screen shown alongside appears on the display. The message “**Optimizer without Rapid Shutdown**” indicates that the measurement is performed on optimizers **not equipped with the rapid shutdown (RSD = Rapid ShutDown) function**. The following parameters are shown:
 - **VTest** → test voltage for insulation measurement
 - **RLim** → minimum limit for insulation measurement
 - Values of voltages VPN, VPE and VNE

OPT		15/10 – 18:04		
Rp --- MΩ				
Optimizer without Rapid Shutdown				
VPN	VPE	VNE		
0V	0V	0V		
1000V	1.0MΩ			
VTest	RLim			

2. **Use the arrow keys (▲,▼)** to access the setting of measurement parameters. The screen on the side appears on the display. Use the arrow keys (◀, ▶) to set the values. The following options are available:
 - **Test Volt** → For safety reasons the test voltage is **fixed to 100VDC**
 - **RLim** → set the minimum reference threshold for the insulation measurement between the values: **0.25, 0.50, 0.60, 1.00, 50MΩ**
 - **R.Shutdown** → set the type of optimizers under consideration with option: **OFF (RSD function not included)**

OPT		15/10 – 18:04		
Test Volt	:	◀	100	▶ V
RLim	:	◀	0.6	▶ MΩ
R.Shutdown	:	◀	OFF	▶
▼				

3. Press **SAVE** key to save the settings
4. Connect the instrument to the output of the series of optimizers associated with the string under test as shown in Fig. 10. Specifically, connect the positive pole output from the **first optimizer** to terminal P, the negative pole output from **the last optimizer** to terminal N, and terminal E to the system's main ground reference



CAUTION

Upon pressing the **GO/STOP** key, different error messages can be displayed by the instrument (see § 6.6.3) and, therefore, the test cannot be started. Check and eliminate, if possible, the problem causing the error message before going on with the test

5. Press **GO/STOP** key to activate the test. In the absence of error conditions and with **VPN voltage ≥ 15V between the P and N terminals**, the message “**Measuring...**” is displayed as shown in the screen on the side.

OPT		15/10 – 18:04		
Rp --- MΩ				
Optimizer without Rapid Shutdown				
VPN	VPE	VNE		
840V	430V	-410V		
Measuring...				
100V	1.0MΩ			
VTest	RLim			

6. At the end of the measurement, the value of the insulation resistance **R_p** obtained from the **parallel resistances of the string/optimizer chain** is shown on the display. If this value is $\geq \mathbf{RLim}$, the message “**OK**” is displayed in case of a positive test result. If this value is $\leq \mathbf{RLim}$, the test has failed and the message “**NOT OK**” is shown on the display

OPT		15/10 – 18:04		
Rp 76 MΩ				
Optimizer without Rapid Shutdown				
V P N	V P E	V N E		
840V	430V	-410V		
OK				
100V	1.0MΩ			
VTest	RLim			



CAUTION

The results of function OPT cannot be saved in the instrument's memory

6.6.3. Anomalous situations

1. **In Rapid Shutdown mode ON**, if the instrument detects a voltage $VPN < 0V$ when pressing **GO/STOP** key, it stops the measurement, emits a long tone, and the message “**Reverse P-N**” is shown on the display. Check the polarity and connections of the instrument to the string + optimizers

OPT 15/10 – 18:04			
Rp --- MΩ			
Optimizer with Rapid Shutdown			
VPN	VPE	VNE	
-10V	-5V	5V	
Reverse P-N			
250V	0.6MΩ	10	1.0V
VTest	RLim	OPT.N	Vlim

2. **In Rapid Shutdown mode ON**, if the instrument detects that the ratio $VPN/N.Opt. > Vlim$ when pressing the **GO/STOP** key, it stops the measurement, emits a long tone and the message “**Optimizer Volt. > Vlim**” is shown on the display. Check the settings and characteristics of the output voltage supplied by each optimizer

OPT 15/10 – 18:04			
Rp --- MΩ			
Optimizer with Rapid Shutdown			
VPN	VPE	VNE	
25V	11V	-14V	
Optimizer Volt. > Vlim			
250V	0.6MΩ	10	1.0V
VTest	RLim	OPT.N	Vlim

3. **In Rapid Shutdown mode ON**, if the instrument detects a voltage $VPN > 30V$ when pressing **GO/STOP** key, it stops the measurement, emits a long tone and the message “**VTot. Optimizer > 30V**” is shown on the display. Check the settings and characteristics of the output voltage supplied by each optimizer

OPT 15/10 – 18:04			
Rp --- MΩ			
Optimizer with Rapid Shutdown			
VPN	VPE	VNE	
65V	31V	-34V	
V.Tot Optimizer. > 30V			
250V	0.6MΩ	10	1.0V
VTest	RLim	OPT.N	Vlim

4. If the instrument detects one of the following conditions on the measured voltages when **GO/STOP** key is pressed:

$$||(\text{AVG}(VPN) - \text{RMS}(VPN))/\text{AVG}(VPN)|| < 0.05$$

$$||(\text{AVG}(VPE) - \text{RMS}(VPE))/\text{AVG}(VPE)|| < 0.05$$

$$||(\text{AVG}(VNE) - \text{RMS}(VNE))/\text{AVG}(VNE)|| < 0.05$$

not satisfied (**presence of AC components on the input voltages**), it stops the measurement, emits a long tone and the message “**VAC > LIM**” is displayed. Check that the string is disconnected from the inverter and that the respective cables are separated from any auxiliary AC voltage sources

OPT 15/10 – 18:04			
Rp --- MΩ			
Optimizer with Rapid Shutdown			
VPN	VPE	VNE	
0V	0V	0V	
VAC > LIM			
250V	0.6MΩ	10	1.0V
VTest	RLim	OPT.N	Vlim

5. **In Rapid Shutdown mode ON** if the instrument detects a short-circuit current **greater than 1A** when pressing **GO/STOP** key, it stops the measurement, emits a long tone and the message “**Isc > Ilim**” is shown on the display. Check the instrument connections to the string+ optimizers

OPT		15/10 – 18:04		
Rp --- MΩ				
Optimizer with Rapid Shutdown				
VPN	VPE	VNE		
10V	5V	-5V		
Isc > Ilim				
250V	0.6MΩ	10	1.0V	
VTest	RLim	OPT.N	Vlim	

6. **In Rapid Shutdown mode OFF**, if the instrument detects a voltage **VPN < 15V** when pressing **GO/STOP** key, it stops the measurement, emits a long tone and the message “**V. Input < 15VDC**” is shown on the display. Check the output voltage from the string + optimizers which must be $\geq 15V$

OPT		15/10 – 18:04		
Rp --- MΩ				
Optimizer without Rapid Shutdown				
VPN	VPE	VNE		
10V	5V	-5V		
V.Input < 15VDC				
100V	1.0MΩ			
VTest	RLim			

6.7. DB – MODULE DATABASE MANAGEMENT

The instrument allows managing **up to a maximum of 63 PV modules Monofacial or Bifacial**, further to a DEFAULT module which can be used as reference case when no information about the type of module being tested is available.

The parameters, **referred to 1 module**, which can be set in the definition are reported in the following Table 1 together with the measuring ranges, resolution and validity conditions:

Item	Description	Range	Resolution	Notes
Prod	Manufacturer's name of module	Max 15 digits		Only CAPITAL
Name	Module name	Max 15 digits		Only CAPITAL
Type	Type of module	Monofacial Bifacial		
Voc	Open-circuit voltage	15.00 ÷ 199.99V	0.01V	$V_{oc} \geq V_{mpp}$
Isc	Short-circuit current	0.50 ÷ 40.00A	0.01A	$I_{sc} \geq I_{mpp}$
Vmpp	Voltage on maximum power point	15.00 ÷ 199.99V	0.01V	$V_{oc} \geq V_{mpp}$
Imp	Current on maximum power point	0.50 ÷ 40.00A	0.01A	$I_{sc} \geq I_{mp}$
Tmp.Isc (α)	Isc temperature coefficient	-0.100÷0.100 %/°C	0.001%/°C	$100 \cdot \alpha / I_{sc} \leq 0.1$
Tmp.Isc (β)	Voc temperature coefficient	-0.999÷-0.001 %/°C	0.001%/°C	$100 \cdot \beta / V_{oc} \leq 0.999$
Coef. Bif.	Coefficient of bifaciality (Bifacial modules only)	0.0 ÷ 100.0%	0.1%	

Table 1: Parameters associated to a PV module

6.7.1. How to define a new PV module

1. Position the cursor onto **DB** by using the arrow keys (**▲**, **▼**) and confirm with **ENTER**. The display shows the screen which contains the type of module selected and the values of the parameters associated to the module

DB		15/10 – 18:04	
Man.	◀	SENEC	▶
Name:	◀	M 4 2 0	▶
Type	:	Bifacial	
Voc	:	38.00 V	
Isc	:	13.99 A	
Tmp.Isc(α)	:	0,046 %/°C	
Tmp.Voc(β)	:	-0,260 %/°C	
Bif.Coef.	:	90.0 %	
37 / 64			
New		Edit	Delete Free

2. Use the arrow keys (**◀**, **▶**) to select the manufacturer of the module (field "**Man.**") and the name of the module (field "**Name**"). Choose by scrolling down the lists of those previously defined and saved.

DB		15/10 – 18:04	
Prod.	◀	SENEC	▶
Name:	◀	M 4 2 0	▶
Type	:	Bifacial	
Voc	:	38.00 V	
Isc	:	13.99 A	
Tmp.Isc(α)	:	0,046 %/°C	
Tmp.Voc(β)	:	-0,260 %/°C	
Bif.Coef.	:	90.0 %	
37 / 64			
New		Edit	Delete Free

3. Press “**New**” (which allows defining a new module) and confirm with **ENTER**. Use the arrow keys of the virtual keyboard to define a name for the module’s manufacturer. Confirm with “**OK**”

SAVE	15/10 – 18:04	
Manufacturer		
SUNPOWER_		
0 1 2 3 4 5 6 7 8 9 0 () % Q W E R T Y U I O P <=> # A S D F G H J K L + - * / & Z X C V B N M . , ; : ! ? _ Ä Ö Ü ß μ Ñ Ç Á Í Ó Ú Û ¿ ÿ Á È É Û Ç Ä Ë Ì Ö Ù Æ Ø Å		
DEL OK NEW		

4. Use the arrow keys of the virtual keyboard to define a name for the module. Confirm with “**OK**”

SAVE	15/10 – 18:04	
Module name		
318WTH_		
0 1 2 3 4 5 6 7 8 9 0 () % Q W E R T Y U I O P <=> # A S D F G H J K L + - * / & Z X C V B N M . , ; : ! ? _ Ä Ö Ü ß μ Ñ Ç Á Í Ó Ú Û ¿ ÿ Á È É Û Ç Ä Ë Ì Ö Ù Æ Ø Å		
DEL OK NEW		

5. Enter the value of each parameter (see Table 1) according to the manufacturer’s data sheet. Position the cursor onto the parameter to be defined by using the arrow keys (▲, ▼) and set the value using the arrow keys (◀, ▶). Keep the arrow keys (◀, ▶) pressed to carry out a quick setting of the values.

6. Press the **SAVE** key to save the settings or the **ESC/MENU** key to exit without saving.

DB	15/10 – 18:04	
Man.	SUNPOWER	
Name:	318WTH	
Type	: ◀ Monofacial ▶	
Voc	: ◀ 64.70 ▶V	
Isc	: ◀ 6.20 ▶A	
Vmpp	: ◀ 54.70 ▶V	
Impp	: ◀ 5.82 ▶A	
Tmp.Isc(α)	: ◀ 0,057 ▶%/°C	
Tmp.Voc(β)	: ◀ -0,127 ▶%/°C	



CAUTION

Upon pressing the **SAVE** key, the instrument checks the conditions indicated in Table 1 and, if one or more of these conditions are not fulfilled, one of the error messages listed in § 6.9 is shown on the display. The instrument does not save the configuration set before any error is solved.

6.7.2. How to modify an existing PV module

1. Select the PV module to be modified from the database by means of the arrow keys (◀, ▶).
2. Select the “**Edit**” command using the arrow key (▼) and confirm selection with **ENTER**.
3. By using the internal virtual keyboard, it is possible to define again the name of the module or leave it unchanged by means of the arrow keys ▲, ▼, ◀, ▶). Confirm with “**OK**” at the bottom of the screen to access the selection of parameters to be modified Press **ENTER** to digit any character of the desired name
4. Press the **SAVE** key to save the modifies

DB		15/10 – 18:04		
Man.	◀	SENEC	▶	
Name:	◀	M 4 3 0	▶	
Type	:	Bifacial		
Voc	:	38.00	V	
Isc	:	14.33	A	
Vmpp	:	31.80	V	
Imp	:	13.53	A	
Temp.Isc(α)	:	0,046	%/°C	
Temp.Voc(β)	:	-0,260	%/°C	
Bif.Coef.	:	90.0	%	
				37 / 64
New		Edit		Delete Free

6.7.3. How to delete an existing PV module

1. Select the PV module from the database by means of the arrow keys (◀, ▶).
2. Press the **ENTER** key and select the “**Delete**” command by means of the arrow key (▼) to delete the selected module.
3. Confirm the selection with **ENTER** or press **ESC/MENU** to exit.
4. The position “**Free**” indicates the residual number of modules which can still be entered into the database with reference to maximum allowed number (**64 modules**)

DB		15/10 – 18:04		
Prod.	◀	SENEC	▶	
Name:	◀	M 4 3 0	▶	
Type	:	Bifacial		
Voc	:	38.00	V	
Isc	:	14.33	A	
Vmpp	:	31.80	V	
Imp	:	13.53	A	
Temp.Isc(α)	:	0,046	%/°C	
Temp.Voc(β)	:	-0,260	%/°C	
Bif.Coef.	:	90.0	%	
				37 / 64
New		Edit		Delete Free



CAUTION

If you delete the last module present in the DB, the instrument automatically generates the DEFAULT module

6.8. IVCK - TEST ON PV MODULES AND STRINGS

6.8.1. Foreword

This function carries out a series of tests on a PV module/string, measuring in a sequence:

- **Open-circuit voltage Voc** of the PV string/module being tested, in compliance with standard IEC/EN62446-1, measured in **OPC** condition (**OP**erative **C**ondition), i.e. in the real conditions in which the installation is, with or without irradiance and temperature measurement.
- **Open-circuit voltage Isc** of the PV string/module being tested, in compliance with standard IEC/EN62446-1, measured in **OPC** condition (**OP**erative **C**ondition), i.e. in the real conditions in which the installation is, with or without irradiance and temperature measurement.
- **Insulation resistance in DUAL mode**, with measurement of values R(+), R(-) and Rp.
- **Continuity of protective conductors with 200mA**

CAUTION



DO NOT perform IVCK measurements on PV strings or modules that integrate MLPEs devices (microinverters, power optimizers, or rapid disconnect devices – RSDs). Performing tests on such configurations **may damage both MLPEs and the instrument** (see § 11.5.3)

CAUTION



- The measurement options “Insulation resistance” and “Continuity of protective conductors” **can be disabled** in the IVCK test (see § 6.8.3)
- With irradiance measurement set to **“OFF” mode** (see § 5.1.4), the measures of Voc and Isc are performed **WITHOUT measuring irradiance and temperature**. In this case, the instrument only given OPC values, compares them to **average values** (rolling average of the last 10 measurements) and displays the result for a comparison with average values
- With the irradiation measurement set to **“Direct” mode** (see § 5.1.4), it can be performed **ONLY on Monofacial modules**
- With irradiance measurement set to **“R. Unit” mode** (see § 5.1.4), it can be carried out through one or more reference cells **HT305 (in case of Bifacial modules)** and with possible temperature probe **PT305**, connected to the remote unit **SOLAR03**, which communicates data in real time to the instrument **via Bluetooth connection**
- When measuring Voc and Isc **WITH measuring irradiance and temperature**, the instrument automatically “converts” the data in OPC conditions to **STC** conditions (**S**tandard **T**est **C**ondition – Irradiance = 1000W/m², Module temperature = 25°C, spectrum distribution AM=1.5) for a comparison to the characteristics declared by the module’s manufacturer
- Irradiation and temperature measurements are recommended when unstable irradiation conditions are present or when comparison with the module’s nominal values declared by the manufacturer is required. In this case, the instrument directly provides the measurement results @ STC

CAUTION



- For the irradiation measurements carried out with the **HT305** reference cell(s) **it is not necessary** to set the relative sensitivity and alpha values which are **automatically** read by the SOLAR03 after connecting these accessories to this remote unit
- In case the Bluetooth connection between instrument and remote unit becomes difficult (too high distance or transmission through walls/obstacles), it is **recommended** to carry out measurements converted to STC conditions activating the **recording** of the irradiation/temperature values read by the SOLAR03 unit (see § 6.8.5)

CAUTION



- The **recommended minimum irradiance threshold is 700W/m²** → the instrument carries out all tests included in I-V test, manages all conditions and error messages of I-V test (wrong numb. of mod., temp. out of range, cell presence, min. irr., etc.) and calculates the STC values of Voc and Isc. This mode is recommended whenever accurate tests are to be carried out on modules/strings being examined
- In general, the result page will include:
 - Irradiance and temperature values (if available)
 - Average values of Voc and Isc calculated as average of the corresponding values under OPC on the last 10 tests saved in the memory. If the number of tests is < 10, the average is calculated on the number of available tests. The first test will display dashes in the field “average values” as there are no previous tests on which to calculate an average.
 - The values of Voc and Isc measured under OPC as well as any partial result (only available if STC values are not available) obtained by comparison with average values.
 - The values of Voc and Isc calculated under STC (if available) and any partial result obtained by comparing the values calculated under STC with the nominal ones (inserted in DB modules)
 - **The overall test outcome (OK/NO). The overall test outcome will be calculated basing on the partial outcomes in STC (if available) or basing on the partial outcomes in OPC (if STC values are not available)**
 - **The instrument will not display any overall outcome if no partial outcome is available**

6.8.2. IVCK Tests without remote unit and without irradiance measurement



CAUTION

- The maximum voltage between inputs P, N, E and C is 1000VDC. Do not measure voltages exceeding the limits given in this manual.
- Do not perform test on PV modules/strings connected to the inverter
- **The maximum current measurable by the instrument is 30A**
- Standard IEC/EN62446-1 requires that measurements are performed string by string. Even if the instrument is designed to manage short circuit current for single strings or strings connected in parallel, we **recommend testing one string at a time** according to the standard's prescriptions.

3. Select "**OFF**" mode in the "**Irr.&Temp**" menu (see § 5.1.4)
4. Position the cursor onto **IVCK** by using the arrow keys (**▲**, **▼**) and confirm with **ENTER**. The display shows the screen to the side: The message "**Irr. Meas. not active**" indicates that no irradiation measurement is required. The following parameters are shown:
 - **VTest** → test voltage for insulation measurement
 - **ISO** → minimum limit for insulation measurement
 - **RPE** → maximum limit for continuity test
 - **>φ<** → calibration resistance of cables for RPE test
 - Values of voltages VPN, VPE and VNE

IVCK	15/10 – 18:04	
Irr. Meas. not active		
Module	318WTH	
VPN	VPE	VNE
980 V	490 V	-490 V
1000V	1.00MΩ	2Ω
VTest	ISO	RPE >φ<

5. Use the arrow keys (▲, ▼) to access the setting of measurement parameters. The screen on the side appears on the display. Use the arrow keys (◀, ▶) to set the values. The following options are available:
 - **Man.** → Set the manufacturer included in the internal DB
 - **Name** → Set the module included in the internal DB
 - **N.Mod x Str** → set the number of modules of the string in range: **1 ÷ 60**
 - **N. Str.par.** → Set the number of strings connected in parallel in range: **1 ÷ 10**
 - **Temp. Mod.** → set the measuring mode of module temperature by choosing among the options:
 - **AUTO** → temperature calculated by the instrument based on the measured Voc (no probe connected) – **recommended option**
 - **MEAS** → temperature measured via probe PT305 connected to remote unit
 - **MAN** → manual setting of module temperature if known in the subsequent range
 - **Tol. Voc** → set percentage tolerance for Voc measurement in range: **1% ÷ 15%** (typical 5%)
 - **Tol. Isc** → set percentage tolerance for Isc measurement in range: **1% ÷ 15%** (typical 10%)
 - **Iso V. Test** → set test voltage for insulation measurement among the options: **OFF** (measurement excluded), **250V, 500V, 1000VDC**

IVCK	15/10 – 18:04	
Man.:	◀ SUNPOWER ▶	
Name:	◀ 318WTH ▶	
N.Mod. x Str.	: ◀ 12 ▶	
N.Str.par.	: ◀ 01 ▶	
Temp.Mod:	: ◀ AUTO ▶	
	: ◀ --- ▶	°C
Tol. Voc	: ◀ 05 ▶	%
Tol. Isc	: ◀ 10 ▶	%
Start&Save	: ◀ MAN ▶	
Start&Save	: RESTART	
Ins V.Test	: ◀ 1000 ▶	V
Ins R.Lim	: ◀ 1.00 ▶	MΩ
RPE lim	: ◀ 2 ▶	Ω
Irr. & Temp.	: ◀ OFF ▶	
Min.Irrad. [W/m2]	: ◀ 700 ▶	
Avg Values	: RESET	
Avg Voc	: ---	V
Avg Isc	: ---	A

- **Start&Save** → set the autostart function mode between the options: **AUTO (function active)** or **MAN (function not active)**
- **Start&Save** → **RESTART** → press **SAVE** key and confirm the restart of the test only if an AutoSave sequence is already in progress and you wish to modify the markers to which to associate the subsequent measurements to be stored
- **Iso R.Lim** → set the minimum reference threshold for insulation measurement among the values: **0.05,0.10,0.23,0.25,0.50,1.00,50,100MΩ**
- **RPE Lim** → set the maximum limit for continuity test among the values: **OFF (measurement excluded), 1,2,3,4,5Ω**
- **Irr. & Temp.** → set irradiance measurement type for IVCK test with the “**OFF**” option (see § 5.1.4)
- **Min. Irrad. [W/m²]** → set the minimum irradiation threshold (for “Direct” and “U. Rem.” modes) (see § 5.1.4)
- **Avg values** → the function “**RESET**” allows zeroing the average values of Voc and Isc parameters before starting a new measurement.
- **Avg Voc, Avg Isc** → average Voc and Isc values in the 10 previously saved tests.

6. Press the **SAVE** key to save settings
7. If necessary, select option “>φ<” and confirm with **ENTER**. Carry out this operation as indicated in § 6.3.1.
8. Connect the instrument to the PV module/string being tested and to the main earth node of the system, and to the metal masses connected to earth as shown in Fig. 11. In particular, connect the negative output pole of the PV module/string to terminal N and the positive output pole of the PV module/string to terminal P.

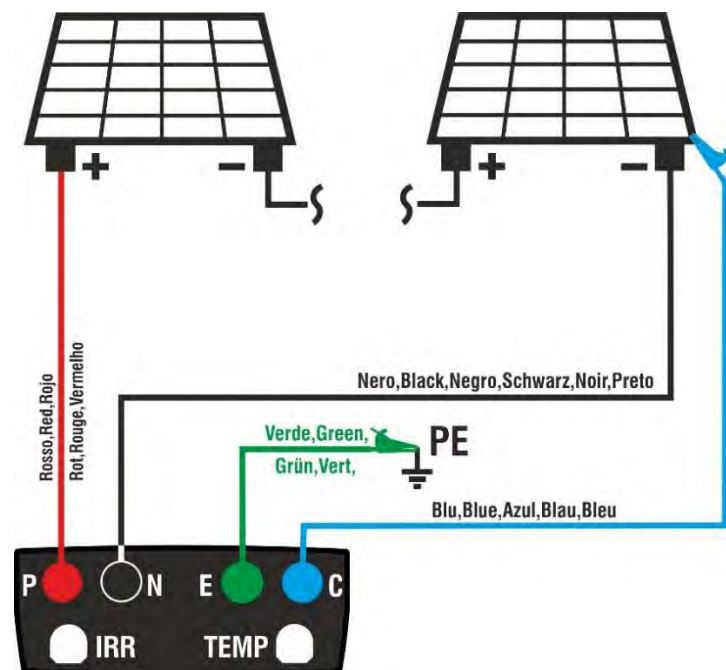

Fig. 11: Connection for IVCK tests without remote unit and without irradiance



CAUTION

Upon pressing the **GO/STOP** key, different error messages can be displayed by the instrument (§ 6.9) and, therefore, the test cannot be started. Check and eliminate, if possible, the problem causing the error message before going on with the test.



CAUTION

In case of tests carried out on a number **N>1** of strings in parallel, the **maximum manageable current** by the instrument is **30A/N**

9. Press the **GO/STOP** key to start the test. In case no error conditions occur, the instrument displays the message **“Measuring...”** and the measure of open-circuit voltage between terminals P and N and of short-circuit current (for Isc values $\leq 30A$)

IVCK		15/10 – 18:04		
Voc@OPC	---	V		
Isc@OPC	---	A		
Avg Voc	---	V		
Avg Isc	---	A		
Rp	---	MΩ		
R+	---	R-	---	MΩ
RPE	---			Ω
Measuring...				
1000V	1.00MΩ	2Ω	---	Ω
VTest	ISO	RPE	>φ<	

10. When Voc@OPC and Isc@OPC measurements are complete, the message **“OK”** is shown in case the result of the test is positive (**measured values within the tolerance values set on the instrument**).

11. With insulation measurement selected, the instrument goes on with the test, keeping terminals P and N short-circuited, and carrying out the test between this point and terminal E for the time necessary to obtain a steady value. The value of insulation resistance is shown in field “Rp” (parallel resistance between values R+ and R-) and the message **“OK”** appears in case the result of the test is positive (**measured value higher than the minimum limit value set on the instrument**).

IVCK		15/10 – 18:04		
Voc@OPC	985	V	OK	
Isc@OPC	11.25	A	OK	
Avg Voc	985	V		
Avg Isc	11.25	A		
Rp	>100	MΩ	OK	
R+	>100	R-	>100	MΩ
RPE	1.1	Ω	OK	
OK				
1000V	1.00MΩ	2Ω	0.2 Ω	
VTest	ISO	RPE	>φ<	

12. With continuity measurement selected, the instrument goes on by opening the short-circuit and carrying out the test between terminals E and C. The value of resistance in the continuity test is shown in field “RPE” and the message **“OK”** appears in case the result of the test is positive (**measured value lower than the maximum limit value set on the instrument**).

13. The message **“Result OK”** is finally shown by the instrument in case the result of all performed tests is positive. For the interpretation of the results see § 6.8.7

14. Press the **SAVE** key to store the test result in the instrument’s memory (see § 7.1) or the **ESC/MENU** key to exit the screen without saving and go back to the main measuring screen.

CAUTION

- The average values of Voc and Isc are displayed in the results page. These values include the **average values of Voc and Isc under OPC conditions calculated as a rolling average of the last 10 tests previously saved**. If the user has carried out and saved a number of tests <10 or reset the average values, the average value displayed during test N+1 will be calculated on the available N values.
- When using the instrument like this, the average values previously calculated are particularly important. In case a new measurement campaign is started with significant variations in irradiance or temperature, **it is advisable to set the average reference values (“RESET”) to zero** to make new calculations based on new measurements. Average values are reset only manually

6.8.3. IVCK Tests without remote unit and irradiance measurement in direct mode

CAUTION



- The maximum voltage between inputs P, N, E and C is 1000VDC. Do not measure voltages exceeding the limits given in this manual.
- Do not perform test on PV modules/strings connected to the inverter
- **The maximum current measurable by the instrument is 30A**
- Standard IEC/EN62446-1 requires that measurements are performed string by string. Even if the instrument is designed to manage inrush current for single strings or strings connected in parallel, we **recommend testing one string at a time** according to the standard's prescriptions.



CAUTION

This mode is valid ONLY for Monofacial modules

1. Select "**Direct**" mode in the "**Irr. & Temperature**" section (see § 5.1.4)
2. Position the cursor onto **IVCK** by using the arrow keys (**▲**, **▼**) and confirm with **ENTER**. The following parameters are shown:

IVCK		15/10 – 18:04		
Irr.	---	W/m2		
Temp.	---	°C		
Module		318WTH		
VPN	VPE	VNE		
980 V	490 V	-490 V		
1000V	1.00MΩ	2Ω	0.25Ω	
VTest	ISO	RPE	>φ<	

- **Irr.** → irradiance values measured by the HT305 cell connected to the "**IRR**" input of the instrument
- **Temp.** → temperature value of the module with PT305 probe connected to the "**TEMP**" input of the instrument or with temperature measurement in "**AUTO**" or "**MAN**" mode without an external probe connected
- **VTest** → test voltage for insulation measurement
- **ISO** → minimum limit for insulation measurement
- **RPE** → maximum limit for continuity test
- **>φ<** → calibration resistance of cables for RPE test
- Values of voltages VPN, VPE and VNE

3. **Use the arrow keys (▲, ▼)** to access the setting of measurement parameters. The screen on the side appears on the display. Use the arrow keys (◀, ▶) to set the values. The following options are available:

IVCK		15/10 – 18:04		
Man.:	◀	SUNPOWER	▶	
Name:	◀	318WTH	▶	
N.Mod. x Str.	:	12	▶	
N.Str.par.	:	01	▶	
Temp.Mod.	:	AUTO	▶	
	:	---	▶ °C	
Tol. Voc	:	05	▶ %	
Tol. Isc	:	10	▶ %	
Start&Save	:	MAN	▶	
Start&Save	:	RESTART	▶	
Iso V.Test	:	1000	▶ V	
Iso R.Lim	:	1.00	▶ MΩ	
RPE lim	:	2	▶ Ω	
Irr. & Temp.	:	Direct	▶	
Min.Irrad. [W/m2]	:	700	▶	
Avg Values	:	RESET	▶	
Avg Voc	:	---	▶ V	
Avg Isc	:	---	▶ A	
		▼		

- **Man.** → Set the manufacturer included in the internal DB
- **Name** → Set the module included in the internal DB
- **N. Mod x STR** → set the number of modules of the string in range: **1 ÷ 60**
- **N. Str.par.** → Set the number of strings connected in parallel in range: **1 ÷ 10**
- **Temp. Mod.** → set the measuring mode of module temperature by choosing among the options:
 - **AUTO** → temperature calculated by the instrument based on the measured Voc (no probe connected) – **recommended option**
 - **MEAS** → temperature measured via probe PT305 connected to remote unit
 - **MAN** → manual setting of module temperature if known in the subsequent range

- **Tol. Voc** → set percentage tolerance for Voc measurement in range: **1% ÷ 15% (typical 5%)**
- **Tol. Isc** → set percentage tolerance for Isc measurement in range: **1% ÷ 15% (typical 10%)**
- **Start&Save** → set the autostart function mode between the options: **AUTO (function active) or MAN (function not active)**
- **Start&Save** → **RESTART** → press **SAVE** key and confirm the restart of the test only if an AutoSave sequence is already in progress and you wish to modify the markers to which to associate the subsequent measurements to be stored
- **Iso V. Test** → set test voltage for insulation measurement among the options: **OFF (measurement excluded), 250V, 500V, 1000VDC**
- **Iso R.Lim** → set the minimum reference threshold for insulation measurement among the values: **0.05,0.10,0.23,0.25,0.50,1.00,50,100MΩ**
- **RPE Lim** → set the maximum limit for continuity test among the values: **OFF (measurement excluded), 1,2,3,4,5Ω**
- **Irr. & Temp.** → set irradiance measurement type for IVCK test with the “**Direct**” option (see § 5.1.4)
- **Min. Irrad. [W/m2]** → set the minimum irradiation threshold (for “Direct” and “U. Rem.” modes) (see § 5.1.4)
- **Avg values** → the function “**RESET**” allows zeroing the average values of Voc and Isc parameters before starting a new measurement.
- **Avg Voc, Avg Isc** → average Voc and Isc values in the 10 previously saved tests.

4. Press the **SAVE** key to save settings

5. If necessary, select option “>φ<” and confirm with **ENTER**. Carry out this operation as indicated in § 6.3.1

6. Assemble the stem onto the disk of the optional accessory **M304** and keep it resting on the module’s surface. **Check that the shadow of the stem on the disk falls within the internal “limit concentric circle” of the disk itself (see picture).** Otherwise, the angle between the sun strays and the module’s surface is too big and, therefore, the measurements carried out by the instrument are NOT to be trusted. **Repeat the operations at other times of the day**

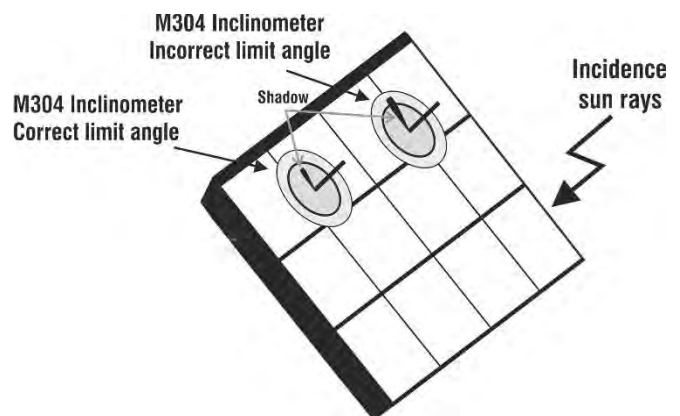

7. Connect the instrument to the PV module/string being tested and to the main earth node of the system, and to the metal masses connected to earth as shown in Fig. 12. In particular, connect the Negative pole output from the module/string to the **N** terminal, the Positive pole output from the module/string to the **P** terminal, the HT305 reference cell **on the front of the module** and the possible PT305 temperature probe on the rear of the module

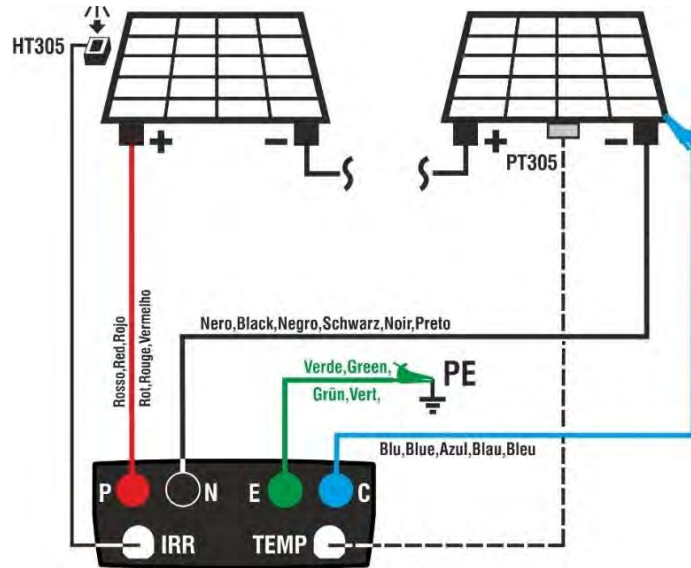

Fig. 12: Connection for IVCK tests without remote unit and direct irradiation measurement



CAUTION

Upon pressing the **GO/STOP** key, different error messages can be displayed by the instrument (§ 6.9) and, therefore, the test cannot be started. Check and eliminate, if possible, the problem causing the error message before going on with the test.



CAUTION

In case of tests carried out on a number **N>1** of strings in parallel, the maximum current manageable by the instrument is **30A/N**

8. Press the **GO/STOP** key to start the test. In case no error conditions occur, the instrument displays the message “**Measuring...**” and the measure of open-circuit voltage between terminals P and N and of short-circuit current (for Isc values $\leq 30A$).

IVCK	15/10 – 18:04			
Voc@STC	---	V		
Isc@STC	---	A		
Avg Voc	---	V		
Avg Isc	---	A		
Rp	---	MΩ		
R+	---	R- ---	MΩ	
RPE	---	Ω		
Measuring...				
1000V	1.00MΩ	2Ω	---	Ω
VTest	ISO	RPE	>φ<	

9. When Voc and Isc measurements are complete, the message “OK” is shown in case the result of the test is positive (**measured values within the tolerance values set on the instrument**). The following parameters are shown:

- Voc voltage at STC conditions with relevant outcome
- Isc current at STC conditions with relevant outcome
- Rated value of voltage Voc@STC used as a reference for outcome
- Rated value of current Isc@STC used as a reference for outcome

IVCK	15/10 – 18:04			
Voc@STC	985	V	OK	
Isc@STC	11.25	A	OK	
Avg Voc	985	V		
Avg Isc	11.25	A		
Rp	>100	MΩ	OK	
R+	>100	R- >100	MΩ	
RPE	1.1	Ω	OK	
OK				
1000V	1.00MΩ	2Ω	0.2 Ω	
VTest	ISO	RPE	>φ<	

10. With insulation measurement selected, the instrument goes on with the test, keeping terminals P and N short-circuited, and carrying out the test between this point and terminal E for the time necessary to obtain a steady value. The value of insulation resistance is shown in field “Rp” (parallel resistance between values R+ and R-) and the message “OK” appears in case the result of the test is positive (**measured value higher than the minimum limit value set on the instrument**).
11. With continuity measurement selected, the instrument goes on by opening the short-circuit and carrying out the test between terminals E and C. The value of resistance in the continuity test is shown in field “RPE” and the message “OK” appears in case the result of the test is positive (**measured value lower than the maximum limit value set on the instrument**).
12. The message “**Result OK**” is finally shown by the instrument in case the result of all performed tests is positive. For the interpretation of the results see § 6.8.7
13. Press the **SAVE** key to store the test result in the instrument’s memory (see § 7.1) or the **ESC/MENU** key to exit the screen without saving and go back to the main measuring screen
14. For the interpretation of the results see § 6.8.7

6.8.4. IVCK Tests with remote unit in direct connection



CAUTION

- Check that no remote unit is currently activated. In case it is not, please carry out the connecting procedure described in § 6.2.
- The maximum voltage between inputs P, N, E and C is 1000VDC. Do not measure voltages exceeding the limits given in this manual.
- Do not perform tests on PV modules/strings connected to the inverter
- **The maximum current measured by the instrument is 30A**
- Standard IEC/EN62446-1 requires that measurements are performed **string by string**. Even if the instrument is designed to manage inrush current for single strings or strings connected in parallel, it is **recommended** testing **one string at a time** according to the standard's prescriptions.

1. Select the “**R. Unit**” mode in the “**Irrad. & Temperature**” section (see § 5.1.4)
2. Select the **UREM** option in the main menu to pair and connect the SOLAR03 remote unit via Bluetooth as shown in § 6.2
3. Connect the instrument to the PV module/string being tested and to the main earth node of the system, and to the metal masses connected to earth as shown in Fig. 13. In detail:
 - Connect the negative output pole of the PV module/string to terminal **N** and the positive output pole of the PV module/string to terminal **P**.
 - **In case of Monofacial modules** → position the reference cell **HT305** respectively onto the front surface of module (**F**) and at input “**INP1**” and **possibly** temperature probe **PT305** at input “**INP4**” of the remote unit
 - **In case of Bifacial modules** → position the **3 reference cells HT305** respectively onto the front surface of module (**F**), onto the back top part (**BH=BackHigh**) and onto the back bottom part (**BL=BackLow**) of the module. Connect the front reference cell (F) to input “**INP1**”, BH reference cell to input “**INP2**”, BL reference cell to input “**INP3**” and **possibly** the temperature probe **PT305** to input “**INP4**” of the remote unit. In accordance with the IEC/EN60904-1-2 standard, the instrument calculates the equivalent front-side Irradiance (**Irr_{eq}**) value, which corresponds to the Irradiance on the front surface only, which produces the same effects as the Irradiance measured on both sides, considering the **bifaciality factor** (φ) of the module according to the following relationship:

$$Irr_{Eq} = Irr_F + \varphi \times Irr_R$$

In which $Irr_R = \min(Irr_{BL}, Irr_{BH})$

4. If necessary, select option “> ϕ <” and confirm with **ENTER**. Carry out a possible calibration of cables as described in § 6.3.1.

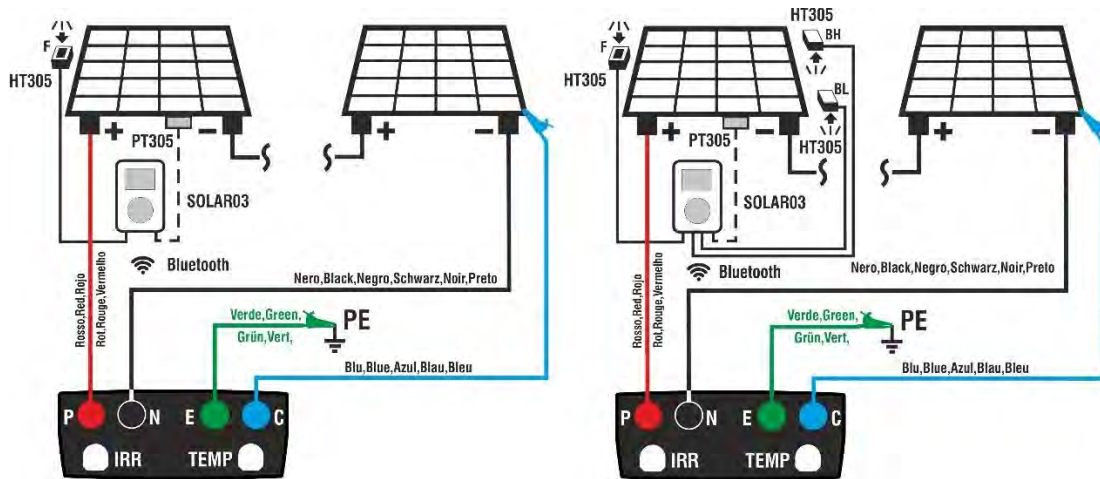

Fig. 13: Connection of SOLAR03 in direct connection on Mono/Bifacial PV modules

5. Position the cursor onto **IVCK** by using the arrow keys (**▲**, **▼**) and confirm with **ENTER**. The display shows the screen to the side: The following parameters are shown in case of **Monofacial** modules:

- **Irr.** → Irradiance values measured by cell HT305 connected to the remote unit
- **Temp.** → Temperature value of module
- **Remote unit** → indications on the serial number, connection status “**ⓘ**”
- **VTest** → test voltage for insulation measurement
- **ISO** → minimum limit for insulation measurement
- **RPE** → maximum limit for continuity test
- **>φ<** → calibration resistance of cables for continuity
- Values of voltages VPN, VPE and VNE

IVCK	15/10 – 18:04		
Irr.	720	W/m ²	
Temp.	45.3	°C	
SOLAR03	23051203	ⓘ	
Module:	318WTH		
VPN	VPE	VNE	
980V	490V	-490V	
1000V	1.00MΩ	2Ω	0.25Ω
VTest	ISO	RPE	>φ<

6. The following parameters are shown in case of **Bifacial** modules:

- **Irr.** → irradiance values measured by the HT305 cells connected to the remote unit (**Front** = front, **Btop** = rear upper part, **Bbot.** = rear lower part)
- **Temp.** → Temperature value of module
- **Remote unit** → indications on the serial number, connection status “**ⓘ**”
- **VTest** → test voltage for insulation measurement
- **ISO** → minimum limit for insulation measurement
- **RPE** → maximum limit for continuity test
- **>φ<** → calibration resistance of cables for continuity
- Values of voltages VPN, VPE and VNE

IVCK	15/10 – 18:04		
Irr.	Front	Btop	Bbot
Temp.	920	125	95
			W/m ²
			°C
SOLAR03	23051203	ⓘ	
Module:	JKM575N-72HL4-BDV		
VPN	VPE	VNE	
980V	490V	-490V	
1000V	1.00MΩ	2Ω	0.25Ω
VTest	ISO	RPE	>φ<

IVCK	15/10 – 18:04	
------	---------------	--

7. Use the arrow keys (▲,▼) to access the setting of measurement parameters. The screen on the side appears on the display. Use the arrow keys (◀, ▶) to set the values. The following options are available:

- **Man.** → Set the manufacturer of the module found in the internal DB
- **Name** → Set the module found in the internal DB. If the modules has been defined as “**Bifacial**”, the instrument and the remote unit will automatically read 3 irradiance values.
- **N. Mod x Str.** → set the number of modules of the string in range: **1 ÷ 60**
- **N. Str par.** → Set the number of strings connected in parallel in range: **1 ÷ 10**

Man.	◀	SUNPOWER	▶
Name:	◀	318WTH	▶
N.Mod. x Str.	:	◀ 12 ▶	▶
N.Str.par.	:	◀ 01 ▶	▶
Temp.Mod.	:	◀ AUTO ▶	▶
	:	◀ --- ▶	°C
Tol. Voc	:	◀ 05 ▶	%
Tol.Isc	:	◀ 10 ▶	%
Start&Save	:	◀ MAN ▶	▶
Start&Save	:	RESTART	▶
Iso V.Test	:	◀ 1000 ▶	V
Iso R.Lim	:	◀ 1.00 ▶	MΩ
RPE lim	:	◀ 2 ▶	Ω
Irr. & Temp	:	◀ R.Unit ▶	▶
Min.Irrad. [W/m2]	:	◀ 700 ▶	▶
Avg Values	:	RESET	▶
Avg Voc	:	---	V
Avg Isc	:	---	A
		▼	

- **Temp. Mod.** → set the measuring mode of module temperature by choosing among the options:
 - **AUTO** → temperature calculated by the instrument based on the measured Voc (no probe connected) – **recommended option**
 - **MEAS** → temperature measured via probe PT305 connected to remote unit
 - **MAN** → manual setting of module temperature if known in the subsequent range
- **Tol. Voc** → set percentage tolerance for Voc measurement in range: **1% ÷ 15%** (typical 5%)
- **Tol. Isc** → set percentage tolerance for Isc measurement in range: **1% ÷ 15%** (typical 10%)
- **Start&Save** → set the autostart function mode between the options: **AUTO (function active)** or **MAN (function not active)**
- **Start&Save** → **RESTART** → press **SAVE** key and confirm the restart of the test only if an AutoSave sequence is already in progress and you wish to modify the markers to which to associate the subsequent measurements to be stored
- **Iso V. Test** → set test voltage for insulation measurement among the options: **OFF (measurement excluded), 250V, 500V, 1000V, 1000VDC**
- **Iso R.Lim** → set the minimum reference threshold for insulation measurement among the values: **0.05,0.10,0.23,0.25,0.50,1.00,50,100MΩ**
- **RPE Lim** → set the maximum limit for continuity test among the values: **OFF (measurement excluded), 1,2,3,4,5Ω**
- **Irr. & Temp.** → set irradiance measurement type for IVCK test with the “**R. Unit**” option (see § 5.1.4)
- **Min. Irrad. [W/m2]** → set the minimum irradiation threshold (for “Direct” and “R.Unit” modes) (see § 5.1.4)
- **Avg values** → the function “**RESET**” allows zeroing the average values of Voc and Isc parameters before starting a new measurement.
- **Avg Voc, Avg Isc** → average Voc and Isc values in the 10 previously saved tests

8. Press the **SAVE** key to save settings and go back to the previous screen.

9. Assemble the stem onto the disk of the optional accessory **M304** and keep it resting on the module's surface. **Check that the shadow of the stem on the disk falls within the internal "limit concentric circle" of the disk itself (see picture).** Otherwise, the angle between the sun strays and the module's surface is too big and, therefore, the measurements carried out by the instrument are NOT to be trusted. **Repeat the operations at other times of the day**

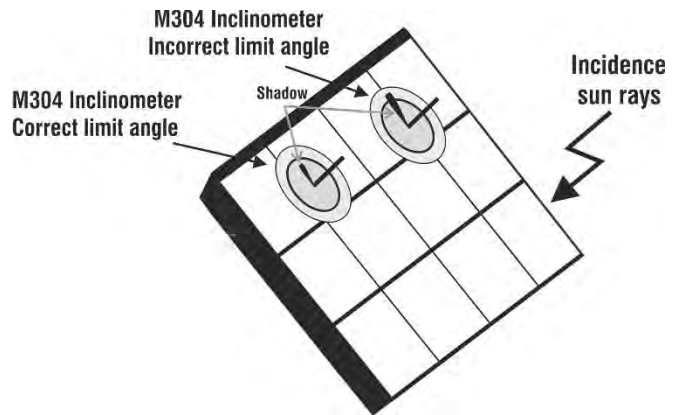

CAUTION

Upon pressing the **GO/STOP** key, different error messages can be displayed by the instrument (§ 6.9) and, therefore, the test cannot be started. Check and eliminate, if possible, the problem causing the error message before going on with the test.



CAUTION

In case of tests carried out on a number **N>1** of strings in parallel, the maximum current manageable by the instrument is **30A/N**

10. Press the **GO/STOP** key to start the test. In case no error conditions occur, the instrument displays the message "**Measuring...**" and the measure of open-circuit voltage between terminals P and N and of short-circuit current (for Isc values $\leq 30A$).

IVCK	15/10 – 18:04			
Voc@STC	---		V	
Isc@STC	---		A	
Voc Nom	---		V	
Isc Nom	---		A	
Rp	---		MΩ	
R+	---	R- ---	MΩ	
RPE	---		Ω	
Measuring...				
1000V	1.00MΩ	2Ω	0.25Ω	
VTest	ISO	RPE	>φ<	

11. At the end of Voc and Isc measurements are complete, the message "OK" is shown in case the result of the test is positive (**measured values within the tolerance values set on the instrument**). The following parameters are shown:

- Voc voltage at STC conditions with relevant outcome
- Isc current at STC conditions with relevant outcome
- Rated value of voltage Voc@STC used as a reference for outcome
- Rated value of current Isc@STC used as a reference for outcome

IVCK	15/10 – 18:04			
Voc@STC	985		V	OK
Isc@STC	11.25		A	OK
Voc Nom	985		V	
Isc Nom	11.25		A	
Rp	>100		MΩ	OK
R+	>100	R- >100	MΩ	OK
RPE	1.1		Ω	OK
OK				
1000V	1.00MΩ	2Ω	0.2 Ω	
VTest	ISO	RPE	>φ<	

12. With insulation measurement selected, the instrument goes on with the test, keeping terminals P and N short-circuited, and carrying out the test between this point and terminal E for the time necessary to obtain a steady value. The value of insulation resistance is shown in field "Rp" (parallel resistance between values R+ and R-) and the message "OK" appears in case the result of the test is positive (**measured value higher than the minimum limit value set on the instrument**)
13. With continuity measurement selected, the instrument goes on by opening the short-circuit and carrying out the test between terminals E and C. The value of resistance in the continuity test is shown in field "RPE" and the message "OK" appears in case the result of the test is positive (**measured value lower than the maximum limit value set on the instrument**)
14. The message **OK** is finally shown by the instrument in case the result of all tests is positive
15. Press the **SAVE** key to store the test result in the instrument's memory (see § 7.1) or the **ESC/MENU** key to exit the screen without saving and go back to the main measuring screen
16. For the interpretation of the results see § 6.8.7

6.8.5. IVCK Tests with remote unit in recording

In this mode, the active SOLAR03 remote unit must be connected via Bluetooth only at the BEGINNING and to the ENDING of the operations and NOT DURING the real irradiation and temperature measurements. The instrument provides the results of measurements @OPC condition without outcome then performs the automatic and simultaneous STC condition translation **only after the data transfer from the remote unit at the end of the recording and the subsequent reconnection.**



CAUTION

- Check that no remote unit is currently activated. In case it is not, please carry out the connecting procedure described in § 6.2.
- The maximum voltage between inputs P, N, E and C is 1000VDC. Do not measure voltages exceeding the limits given in this manual.
- Do not perform tests on PV modules/strings connected to the DC/AC converter
- **The maximum current measured by the instrument is 30A**
- Standard IEC/EN62446-1 requires that measurements are performed **string by string**. Even if the instrument is designed to manage inrush current for single strings or strings connected in parallel, it is **recommend** testing **one string at a time** according to the standard's prescriptions.

1. Select the "**R. Unit**" mode in the "**Irrad. & Temperature**" section (see § 5.1.4)
2. Connect the instrument to the PV module/string being tested and to the main earth node of the system, and to the metal masses connected to earth as shown in Fig. 14 (Mono-facial modules) or Fig. 15 (Bifacial modules) In detail:
 - Connect the negative output pole of the PV module/string to terminal **N** and the positive output pole of the PV module/string to terminal **P**.
 - **In case of Mono-facial modules** → position the reference cell **HT305** onto the front surface of module (**F**) and at input "**INP1**" and **possibly** temperature probe **PT305** at input "**INP4**" of the remote unit.
 - **In case of Bifacial modules** → position the **3 reference cells HT305** respectively onto the front surface of module (**F**), onto the back top part (**BH=BackHigh**) and onto the back bottom part (**BL=BackLow**) of the module. Connect the front reference cell (F) to input "**INP1**", BH reference cell to input "**INP2**", BL reference cell to input "**INP3**" and **possibly** the temperature probe **PT305** to input "**INP4**" of the remote unit. In accordance with the IEC/EN60904-1-2 standard, the instrument calculates the equivalent front-side Irradiance (**Irreq**) value, which corresponds to the Irradiance on the front surface only, which produces the same effects as the Irradiance measured on both sides, considering the **bifaciality factor** (φ) of the module according to the following relationship:

$$Irr_{Eq} = Irr_F + \varphi \times Irr_R$$

In which $Irr_R = \min(Irr_{BL}, Irr_{BH})$

3. If necessary, select option "> ϕ <" and confirm with **ENTER**. Carry out a possible calibration of cables as described in § 6.3.1.

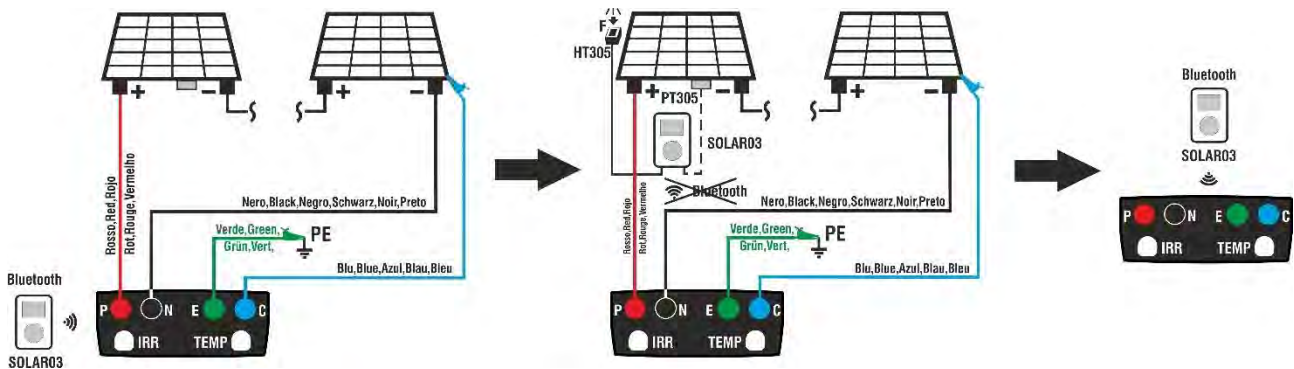

Fig. 14: Connection of SOLAR03 in recording on Monofacial PV modules

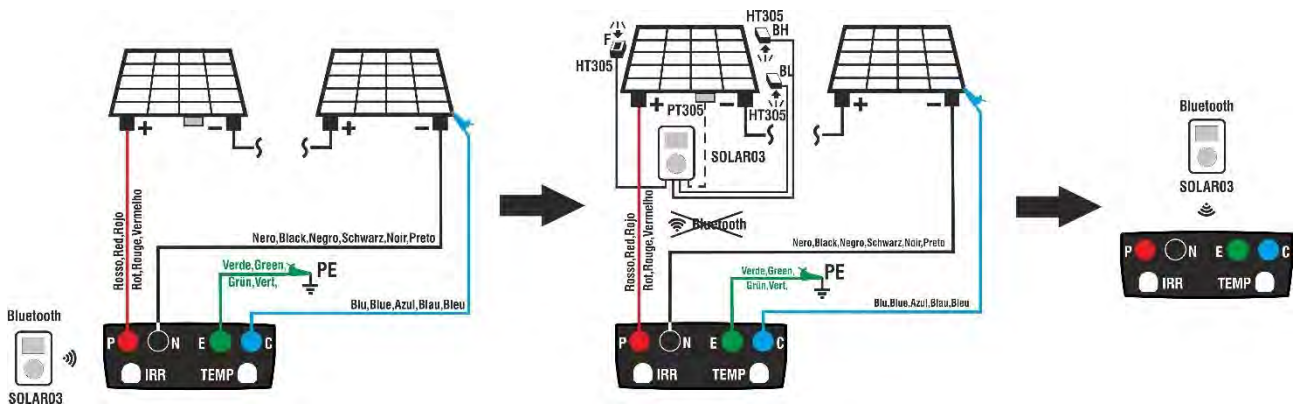

Fig. 15: Connection of SOLAR03 in recording on Bifacial PV modules

Step 1

4. Move the SOLAR03 remote unit close to the instrument as shown in Fig. 14 or Fig. 15 – left side part
5. Select option **UREM** from the main menu, pair and connect the remote unit SOLAR03 to the instrument as shown in step 6 of § 6.2
6. Use the arrow keys ◀ or ▶ to select “**Start**” to start the instrument’s recording (**with non-modifiable 1s scan**) with the remote unit. The screen on the side appears on the display. In this condition, the instrument sends its system date / time to the remote unit SOLAR03, which is **time synchronized** with it. The symbol “**∞**” appears on the display and the message “**REC**” appears on the remote unit’s display to indicate that recording is in progress.

UREM 15/10 – 18:04			
SOLAR03	Act	Status	Rec.
23051204	✓	(∞)	∞
U. Rem. Connected			
Find	Unpair	Delete	Start

Step 2

7. Move the remote unit close the modules and connect the irradiance/temperature probes as shown Fig. 14 or Fig. 15 – middle side part. **Since recording has already been activated on remote unit SOLAR03, it is not necessary to maintain the Bluetooth connection anymore.** Maintaining the connection (if possible) will only allow to immediately obtain the outcome of the test without waiting for the measuring campaign to be completed.

8. Position the cursor onto **IVCK** by using the arrow keys (**▲**, **▼**) and confirm with **ENTER**. The following parameters are shown (case of Monofacial module):

- **Irr.** → irradiation value not indicated “- - -” as remote unit not connected to the instrument
- **Temp.** → Temperature value of module not indicated “- - -” as remote unit not connected to the instrument
- **Remote unit** → indications on the serial number, connection status “**1**” and recording in progress “**∞**” of the SOLAR03 remote unit connected and active
- **VTest** → test voltage for insulation measurement
- **ISO** → minimum limit for insulation measurement
- **RPE** → maximum limit for continuity test
- **>φ<** → calibration resistance of cables for continuity test
- Values of voltages VPN, VPE and VNE

IVCK 15/10 – 18:04			
Irr.	---	W/m ²	
Temp.	---	°C	
SOLAR03	23051203	1	∞
Module:	318WTH		
V PN	V PE	V NE	
980 V	490 V	-490 V	
1000V	1.00MΩ	2Ω	0.25Ω
VTest	ISO	RPE	>φ<

9. Use the arrow keys (▲,▼) to access the setting of measurement parameters. The screen on the side appears on the display. Use keys (◀, ▶) to set the values:

- **Man.** → Set the manufacturer of the module found in the internal DB
- **Name** → Set the module found in the internal DB. If the modules have been defined as “**Bifacial**”, the instrument and the remote unit will automatically read 3 irradiance values
- **N. Mod x Str.** → set the number of modules of the string in range: **1 ÷ 60**
- **N. Str.par.** → Set the number of strings connected in parallel in range: **1 ÷ 10**
- **Mod. Temp** → set the measuring mode of module temperature by choosing between the options:

IVCK 15/10 – 18:04			
Man.	◀	SUNPOWER	▶
Name:	◀	318WTH	▶
N.Mod. x Str.	: ◀	12	▶
N.Str.par.	: ◀	01	▶
Temp.Mod.	: ◀	AUTO	▶
	: ◀	---	▶
Tol. Voc	: ◀	05	▶ %
Tol. Isc	: ◀	10	▶ %
Start&Save	: ◀	MAN	▶
Start&Save	:	RESTART	
Iso V. Test	: ◀	1000	▶ V
Iso R.Lim	: ◀	1.00	▶ MΩ
RPE lim	: ◀	2	▶ Ω
Irr. & Temp.	: ◀	R.Unit	▶
Min.Irrad. [W/m ²]	: ◀	700	▶
Avg Values	:	RESET	
Avg Voc	: ◀	---	▶ V
Avg Isc	: ◀	---	▶ A

- **AUTO** → temperature calculated by the instrument based on the measured Voc (no probe connected) – **recommended option**
- **MEAS** → temperature measured via probe PT305 connected to remote unit
- **MAN** → manual setting of module temperature if known in the subsequent range
- **Tol. Voc** → set percentage tolerance for Voc in range: **1% ÷ 15% (typical 5%)**
- **Tol. Isc** → set percentage tolerance for Isc in range: **1% ÷ 15% (typical 10%)**
- **Start&Save** → set the autostart function mode between the options: **AUTO (function active)** or **MAN (function not active)**
- **Start&Save** → **RESTART** → press **SAVE** key and confirm the restart of the test only if an AutoSave sequence is already in progress and you wish to modify the markers to which to associate the subsequent measurements to be stored
- **Iso V. Test** → set test voltage for insulation in the options: **OFF, 250V, 500V, 1000VDC**
- **Iso R.Lim** → set the minimum reference threshold for insulation measurement among the values: **0.05, 0.10, 0.23, 0.25, 0.50, 1.00, 50, 100MΩ**
- **RPE Lim** → set maximum limit for continuity test between options: **OFF, 1, 2, 3, 4, 5Ω**
- **Irr. & Temp.** → set irradiance measure type for IVCK test with the “**R. Unit**” option
- **Min. Irrad. [W/m²]** → set the minimum irradiation threshold (see § 5.1.4)
- **Avg values** → the function “**RESET**” allows zeroing the average values of Voc and Isc parameters before starting a new measurement
- **Avg Voc, Avg Isc** → average Voc and Isc values in the 10 previously saved tests

10. Press the **SAVE** key to save settings and go back to the previous screen
11. Assemble the stem onto the disk of the optional accessory **M304** and keep it resting on the module's surface. **Check that the shadow of the stem on the disk falls within the internal "limit concentric circle" of the disk itself (see picture).** Otherwise, the angle between the sun strays and the module's surface is too big and, therefore, the measurements carried out by the instrument are NOT to be trusted. **Repeat the operations at other times of the day**

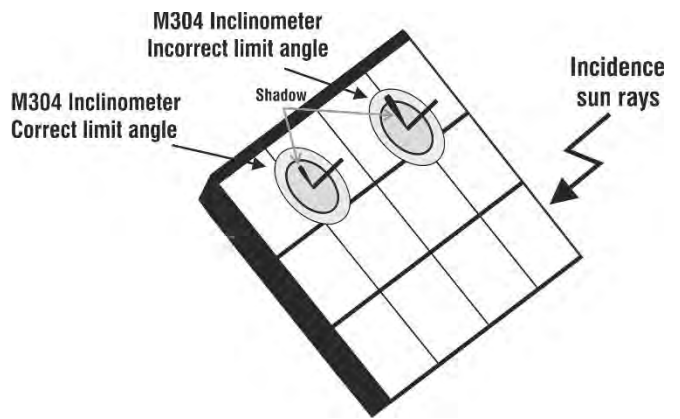

CAUTION

- Upon pressing the **GO/STOP** key, different error messages can be displayed by the instrument (§ 6.9) and, therefore, the test cannot be started. Check and eliminate, if possible, the problem causing the error message before going on with the test
- The settings made on the instrument control parameters can be modified at any time even while recording is in progress



CAUTION

In case of tests carried out on a number **N>1** of strings in parallel, the **maximum current manageable** by the instrument is **30A/N**

12. Press the **GO/STOP** key to activate the desired tests on the strings under examination. In case no error conditions occur, the instrument displays the message "**Measuring...**" and the measure of open-circuit voltage between terminals P and N and of short-circuit current (for Isc values $\leq 30A$).

IVCK		15/10 – 18:04			
Voc@STC	---	V			
Isc@STC	---	A			
Voc Nom	---	V			
Isc Nom	---	A			
Rp	---	MΩ			
R+	---	R-	---	MΩ	
RPE	---	Ω			
Measuring...					
1000V	1.00MΩ	2Ω	0.25Ω		
VTest	ISO	RPE	>φ<		
Voc@OPC	085	V			
Isc@OPC	11.25	A			
Voc Nom	985	V			
Isc Nom	11.25	A			
Rp	>100	MΩ	OK		
R+	>100	R- >100	MΩ	OK	
RPE	1.1	Ω	OK		
1000V	1.00MΩ	2Ω	0.2 Ω		
VTest	ISO	RPE	>φ<		

13. With insulation measurement selected, the instrument goes on with the test, keeping terminals P and N short-circuited, and carrying out the test between this point and terminal E for the time necessary to obtain a steady value. The value of insulation resistance is shown in field "Rp" (parallel resistance between values R+ and R-) and the message "OK" appears in case the result of the test is positive (**measured value higher than the minimum limit value set on the instrument**)
14. With continuity measurement selected, the instrument goes on by opening the short-circuit and carrying out the test between terminals E and C. The value of resistance in the continuity test is shown in field "RPE" and the message "OK" appears in case the result of the test is positive (**measured value lower than the maximum limit value set on the instrument**)
15. Press the **SAVE** key to store the test result in the instrument's memory (see § 7.1) or the **ESC/MENU** key to exit the screen without saving and go back to the main measuring screen.

Step 3

17. Once testing has ended, disconnect the remote unit SOLAR03, move it back close to the instrument (see Fig. 14 or Fig. 15 – right side part) and check that the connection to the instrument is active again (symbol "⌘" on **and steady** on the remote unit's display).

18. Enter in the **UREM** section and by using arrow keys ◀ or ▶ to select "**Stop**" to stop the instrument's recording with the remote unit. The screen on the side appears on the display. The symbol "∞" disappears from the display and the message "REC" disappears from the remote unit's display. In this phase, the remote unit downloads the irradiance/temperature recorded during the measuring campaign. These values are used by the instrument for an automatic conversion of Voc and Isc values to STC conditions.

UREM 15/10 – 18:04			
SOLAR03	Act	Status	Rec.
23051204	√	((↑))	
U.Rem. Connected			
Find	Unpair	Delete	Stop

19. The data present in the measurements previously saved in memory will be updated with the values calculated under STC conditions and the "OK" message will consequently be available in the event of a positive outcome of all the tests performed (**values measured within the tolerances set on the instrument**)

IVCK 15/10 – 18:04			
Voc@STC	985	V	OK
Isc@STC	11.25	A	OK
Voc Nom	985	V	
Isc Nom	11.25	A	
Rp	>100	MΩ	OK
R+	>100	R- >100 MΩ	
RPE	1.1	Ω	OK
OK			
1000V	1.00MΩ	2Ω	0.2 Ω
VTest	ISO	RPE	>φ<

20. For the interpretation of the results see § 6.8.7

CAUTION

The instrument translates @OPC results to @STC values when the following conditions occur:



- Voltage **Voc** > **Voc minimum = 15V**
- **Frontal** irradiance values (also valid for bifacial modules) detected as greater than the minimum threshold set on the instrument (>100W/m²) and **stable** (variation between the start and end of the measurement campaign **±20 W/m²**)
- Open voltage Voc measured consistent with expected value indicated in the module datasheet
- Module temperature value included in the range: **-40°C ÷ 100°C (-40°F ÷ 212°F)**
- Short-circuit current value **Isc** > **Iscmin = 0.2A**

6.8.6. IVCK Tests with Start&Save function



CAUTION

- The maximum voltage between inputs P, N, E and C is 1000VDC. Do not measure voltages exceeding the limits given in this manual.
- Do not perform test on PV modules/strings connected to the inverter
- **The maximum current measurable by the instrument is 30A**
- Standard IEC/EN62446-1 requires that measurements are performed **string by string**. Even if the instrument is designed to manage inrush current for single strings or strings connected in parallel, we **recommend** testing **one string at a time** according to the standard's prescriptions.



CAUTION

- The Start&Save function can be used in any measurement configuration for the environmental parameters of irradiance and temperature.
- The Start&Save function is available **ONLY for IVCK tests** and **not for individual RPE, MΩ, or GFL tests**
- The Start&Save function is **automatically disabled** when the IVCK function exits and/or if the instrument is turned off
- The purpose of the Start&Save function is to **minimize IVCK test execution times** in repetitive situations and with closely spaced circuits, such as fuse elements. This function is **strongly discouraged if string protection fuses are not present in field panels and/or PV combiner panels**

1. For simplicity, the following procedure refers to the **IVCK test without a remote unit and without irradiance measurement**. Similar considerations apply to all other modes

2. Position the cursor onto **IVCK** by using the arrow keys (▲, ▼) and confirm with **ENTER**. The following parameters are shown:

- **VTest** → test voltage for insulation measurement
- **ISO** → minimum limit for insulation measurement
- **RPE** → maximum limit for continuity test
- **>φ<** → calibration resistance of cables for RPE test
- Values of voltages VPN, VPE and VNE

IVCK	15/10 – 18:04	AS&S	
Irr. Meas. not active			
Module	318WTH		
VPN	VPE	VNE	
0V	0V	0V	
1000V	1.00MΩ	2Ω	
VTest	ISO	RPE	>φ<

3. **Use the arrow keys (▲,▼)** to access the setting of measurement parameters. The screen on the side appears on the display. Use the arrow keys (◀, ▶) to set the values. The following options are available:

- **Man.** → Set the module manufacturer name included in the internal DB
- **Name** → Set the module included in the internal DB
- **N.Mod x Str** → set the number of modules of the string in range: **1 ÷ 60**
- **N. Str.par.** → Set the number of strings connected in parallel in range: **1 ÷ 10**
- **Temp. Mod.** → set the measuring mode of module temperature by choosing among the options:
 - **AUTO** → temperature calculated by the instrument based on the measured Voc (no probe connected) – **recommended option**
 - **MEAS** → temperature measured via probe PT305 connected to remote unit
 - **MAN** → manual setting of module temperature if known in the subsequent range

IVCK 15/10 – 18:04		AS&S	
Man.:	◀	SUNPOWER	▶
Name:	◀	318WTH	▶
N.Mod. x Str.	:	◀ 12 ▶	
N.Str.par.	:	◀ 01 ▶	
Temp.Mod:	:	◀ AUTO ▶	
	:	◀ --- ▶	°C
Tol. Voc	:	◀ 05 ▶	%
Tol.Isc	:	◀ 10 ▶	%
Start&Save	:	◀ AUTO ▶	
Start&Save	:	RESTART	
Ins V.Test	:	◀ 1000 ▶	V
Ins R.Lim	:	◀ 1.00 ▶	MΩ
RPE lim	:	◀ 2 ▶	Ω
Irr. & Temp.	:	◀ OFF ▶	
Min.Irrad. [W/m2]	:	◀ 700 ▶	
Avg Values	:	RESET	
Avg Voc	:	---	V
Avg Isc	:	---	A

- **Tol. Voc** → set percentage tolerance for Voc measurement in range: **1% ÷ 15% (typical 5%)**
 - **Tol. Isc** → set percentage tolerance for Isc measurement in range: **1% ÷ 15% (typical 10%)**
 - **Iso V. Test** → set test voltage for insulation test between: **OFF, 250V, 500V, 1000VDC**
 - **Start&Save** → set the autostart function in **AUTO** mode (**function active**). The “AS&S” symbol is shown on the display
 - **Start&Save** → **RESTART** → press **SAVE** key and confirm the restart of the test only if an AutoSave sequence is already in progress and you wish to modify the markers to which to associate the subsequent measurements to be stored
 - **Iso R.Lim** → set the minimum reference threshold for insulation measurement among the values: **0.05, 0.10, 0.23, 0.25, 0.50, 1.00, 50, 100MΩ**
 - **RPE Lim** → set the maximum limit for continuity test among the values: **OFF (measurement excluded), 1, 2, 3, 4, 5Ω**
 - **Irr. & Temp.** → set irradiance measurement with the “OFF” option (see § 5.1.4)
 - **Min. Irrad. [W/m2]** → set the minimum irradiation threshold (for “Direct” and “U. Rem.” modes) (see § 5.1.4)
 - **Avg values** → the function “RESET” allows zeroing the average values of Voc and Isc parameters before starting a new measurement.
 - **Avg Voc, Avg Isc** → average Voc and Isc values in the 10 previously saved tests.
4. Press the **SAVE** key to save settings
5. If necessary, select option “>φ<” and confirm with **ENTER** (see § 6.3.1)
6. Inside a **PV combiner panel**, **disconnect all fuses** associated with the **positive poles of the strings**. For safety reason, disconnect the fuses connected to both poles
7. Connect the instrument as shown in Fig. 16. In particular, connect the negative pole of the bar to the **N** input via a fixed connection with a crocodile terminal, the positive pole of the bar to the **P** input via a fixed connection with a crocodile terminal, the main earth node of the system (for MΩ and RPE tests) to the **E** input and, if necessary, the **C** input to the metal masses (for RPE tests).

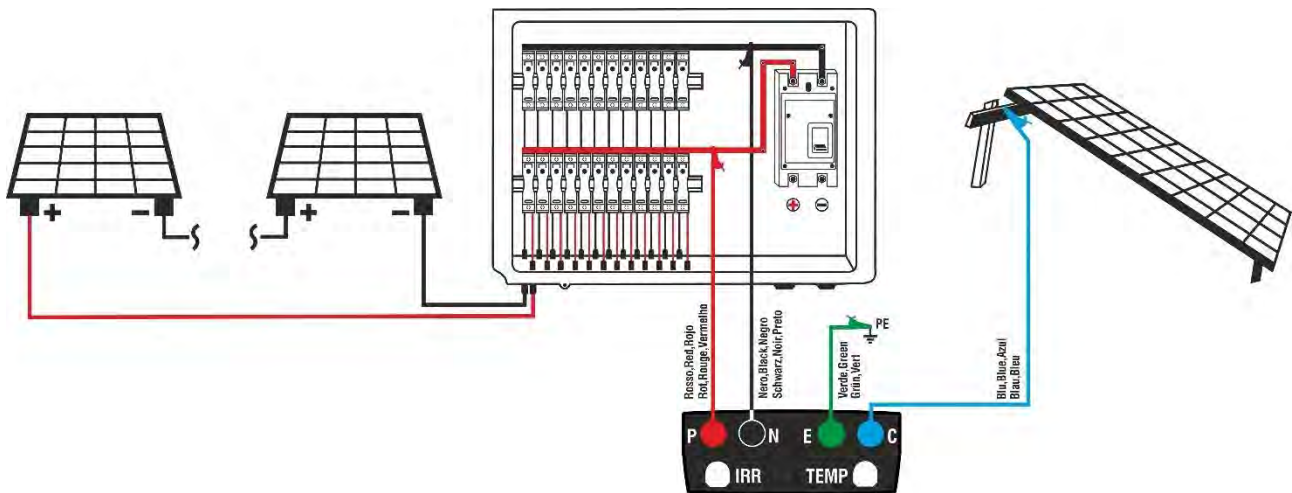

Fig. 16: Connection for IVCK tests with Start&Save function

8. Restore the fuse associated to the FIRST string under test

9. Starts the IVCK test sequence (with possible $M\Omega$ and RPE) by using the **GO/STOP** key
10. If the test sequence is completed correctly, the instrument displays:
 - The outcome page for a few seconds as shown in the following screen
 - The memory area page with the marker display (see § 7.1). Modify the marker values and any comments in a manner consistent with the position of the measurement just taken
 - Press the **SAVE** key to save the test results

IVCK	15/10 – 18:04	AS&S	
Irr. Meas. not active			
Module	318WTH		
VPN	VPE	VNE	
980 V	490 V	-490 V	
Disconnect circuit			
1000V	1.00M Ω	2 Ω	
VTest	ISO	RPE	> ϕ <

11. After saving the test, the instrument returns to the initial screen and displays the **“Disconnect circuit”** message
12. Disconnect the fuse of the string just tested
13. **Restore the fuse associated with the next string to be tested**
14. **When the instrument detects a stable VPN voltage >30V**, it automatically starts the new IVCK test sequence at the end of which it will **automatically save** the results by associating them with the previous marker configuration

IVCK	15/10 – 18:04		
Voc@OPC	985	V	
Isc@OPC	11.25	A	
Avg Voc	985	V	
Avg Isc	11.25	A	
Rp	>100	M Ω	
R+	>100	R- >100 M Ω	
RPE	---	Ω	
OK			
1000V	1.00M Ω	2 Ω	--- Ω
VTest	ISO	RPE	> ϕ <

15. Repeat the steps indicated from point 12 to point 14 for all the strings to be tested
16. The instrument automatically exits the Start&Save sequence when one of the following conditions occurs:
 - Exiting the IVCK function
 - Turning off the instrument
 - Disabling the Start&Save function
 - Reaching the maximum number of saved tests for each marker (max 999)
 - Any hardware error conditions during a measurement

6.8.7. Interpretation of measurement results

In general, the result of a test on a Voc and Isc measurement is determined by the following relationships:

Measurements without remote unit (no irradiation and temperature)

Note the following parameters:

VocAve → average open voltage value calculated in the last 10 saved measurements

IscAve → average short circuit current value calculated in the last 10 saved measurements

Voc (Tol+) = Tol%(+)Voc * VocAve → Positive tolerance value on Voc

Voc (Tol-) = Tol%(-)Voc * VocAve → Negative tolerance value on Voc

Isc (Tol+) = Tol%(+)Isc * IscAve → Positive tolerance value on Isc

Isc (Tol-) = Tol%(-)Isc * IscAve → Negative tolerance value on Isc

$\epsilon_{\text{InstrumVoc}}$ → Maximum instrumental error declared on the Voc @OPC (see § 10.1)

$\epsilon_{\text{InstrumIsc}}$ → Maximum instrumental error declared on the Isc @OPC (see § 10.1)

The following check parameters are calculated by the instrument:

$\epsilon_{\text{MeasVoc}}$ = Voc (@OPC) – VocAve → Error on the measurement of Voc @ OPC

$\epsilon_{\text{MeasIsc}}$ = Isc (@OPC) – IscAve → Error on the measurement of Isc @ OPC

The following conditions on the measurement outcome are managed by the instrument:

N	CONDITION	OUTCOME
1	<ul style="list-style-type: none"> ➤ - Voc (Tol-) + $\epsilon_{\text{InstrumVoc}} \leq \epsilon_{\text{MeasVoc}} \leq \text{Voc (Tol+) - } \epsilon_{\text{InstrumVoc}}$ ➤ - Isc (Tol-) + $\epsilon_{\text{InstrumIsc}} \leq \epsilon_{\text{MeasIsc}} \leq \text{Isc (Tol+) - } \epsilon_{\text{InstrumIsc}}$ ➤ $R_p \geq R_p \text{ Lim}$ → if INSULATION test selected ➤ $RPE_{\text{mis}} \leq RPE_{\text{Lim}}$ → if RPE test selected 	OK
2	<ul style="list-style-type: none"> ➤ - Voc (Tol-) ≤ $\epsilon_{\text{MeasVoc}} \leq \text{Voc (Tol+)}$ ➤ - Isc (Tol-) ≤ $\epsilon_{\text{MeasIsc}} \leq \text{Isc (Tol+)}$ ➤ $R_p \geq R_p \text{ Lim}$ → if INSULATION test selected ➤ $RPE_{\text{mis}} \leq RPE_{\text{Lim}}$ → if RPE test selected 	OK*
3	<ul style="list-style-type: none"> ➤ - Voc (Tol-) – $\epsilon_{\text{InstrumVoc}} \leq \epsilon_{\text{MeasVoc}} \leq \text{Voc (Tol+) + } \epsilon_{\text{InstrumVoc}}$ ➤ - Isc (Tol-) – $\epsilon_{\text{InstrumIsc}} \leq \epsilon_{\text{MeasIsc}} \leq \text{Isc (Tol+) + } \epsilon_{\text{InstrumIsc}}$ ➤ $R_p \geq R_p \text{ Lim}$ → if INSULATION test selected ➤ $RPE_{\text{mis}} \leq RPE_{\text{Lim}}$ → if RPE test selected 	NO OK*
4	Previous conditions (1), (2) and (3) are not verified	NO OK

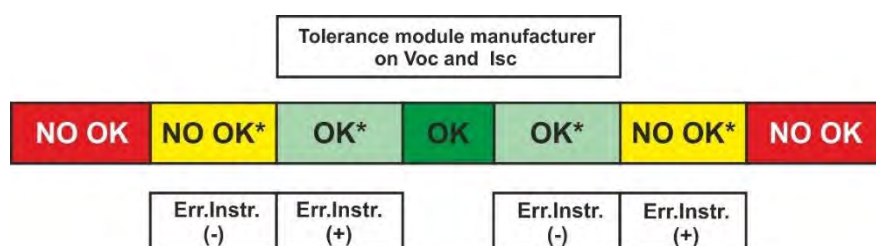

Measurements with remote unit (irradiation and temperature)

Note the following parameters:

VocNom → nominal open voltage value of Voc (declared by the manufacturer)

IscNom → nominal short circuit current value of Isc (declared by the manufacturer)

Voc (Tol+) = Tol%(+)Voc * VocNom → Positive tolerance value on Voc

Voc (Tol-) = Tol%(-)Voc * VocNom → Negative tolerance value on Voc

Isc (Tol+) = Tol%(+)Isc * IscNom → Positive tolerance value on Isc

Isc (Tol-) = Tol%(-)Isc * IscNom → Negative tolerance value on Isc

$\epsilon_{\text{InstrumVoc}}$ → Maximum instrumental error declared on the Voc @STC (see § 10.1)

$\epsilon_{\text{InstrumIsc}}$ → Maximum instrumental error declared on the Isc @STC (see § 10.1)

The following check parameters are calculated by the instrument:

$\epsilon_{\text{MeasVoc}}$ = Voc (@STC) – VocNom → Error on the measurement of Voc @ STC

$\epsilon_{\text{MeasIsc}}$ = Isc (@STC) – IscNom → Error on the measurement of Isc @ STC

NOTE: Voc (@STC) and Isc (@OPC) values are obtained in accordance with IEC/EN60891

The following conditions on the measurement outcome are managed by the instrument:

N	CONDITION	OUTCOME
1	<ul style="list-style-type: none"> ➤ - Voc (Tol-) + $\epsilon_{\text{InstrumVoc}} \leq \epsilon_{\text{MeasVoc}} \leq \text{Voc (Tol+) - } \epsilon_{\text{InstrumVoc}}$ ➤ - Isc (Tol-) + $\epsilon_{\text{InstrumIsc}} \leq \epsilon_{\text{MeasIsc}} \leq \text{Isc (Tol+) - } \epsilon_{\text{InstrumIsc}}$ ➤ Rp ≥ Rp Lim → if INSULATION test selected ➤ RPEmis ≤ RPELim → if RPE test selected 	OK
2	<ul style="list-style-type: none"> ➤ - Voc (Tol-) ≤ $\epsilon_{\text{MeasVoc}} \leq \text{Voc (Tol+)}$ ➤ - Isc (Tol-) ≤ $\epsilon_{\text{MeasIsc}} \leq \text{Isc (Tol+)}$ ➤ Rp ≥ Rp Lim → if INSULATION test selected ➤ RPEmis ≤ RPELim → if RPE test selected 	OK*
3	<ul style="list-style-type: none"> ➤ - Voc (Tol-) – $\epsilon_{\text{InstrumVoc}} \leq \epsilon_{\text{MeasVoc}} \leq \text{Voc (Tol+) + } \epsilon_{\text{InstrumVoc}}$ ➤ - Isc (Tol-) – $\epsilon_{\text{InstrumIsc}} \leq \epsilon_{\text{MeasIsc}} \leq \text{Isc (Tol+) + } \epsilon_{\text{InstrumIsc}}$ ➤ Rp ≥ Rp Lim → if INSULATION test selected ➤ RPEmis ≤ RPELim → if RPE test selected 	NO OK*
4	Previous conditions (1), (2) and (3) are not verified	NO OK

Tolerance module manufacturer
on Voc and Isc



Err.Instr. (-)	Err.Instr. (+)
-------------------	-------------------

Err.Instr. (-)	Err.Instr. (+)
-------------------	-------------------

Application example (measurement with remote unit)

- Module name: **LR5-54HIH-410M (LONGI manufacturer)**
- Module type: Mono-facial
- Declared nominal Voc voltage (@STC): 37.3V
- Declared nominal short circuit current Isc (@ STC): 13.88A
- Tolerance Voc: ±5%
- Tolerance Isc: ±10%
- Frontal irradiance measured: 577 W/m²
- Module temperature (@STC): 25°C
- Voltage Voc calculated by the instrument (@STC): 37.1V
- Short circuit current Isc calculated by the instrument (@STC): 10.53A

$$Voc (Tol+) = Tol\%(+)Voc * VocNom = 0.05 * 37.3V = 1.9V$$

$$Voc (Tol-) = Tol\%(-)Voc * VocNom = 0.05 * 37.3V = 1.9V$$

$$Isc (Tol+) = Tol\%(+)Isc * IscNom \rightarrow = 0.1 * 13.88 = 1.39A$$

$$Isc (Tol-) = Tol\%(-)Isc * IscNom \rightarrow = 0.1 * 13.88 = 1.39A$$

$$\epsilon_{Instrum}Voc = \pm(37.1 * 0.04 + 0.2) = \pm 1.7V$$

$$\epsilon_{Instrum}Isc = \pm(10.53 * 0.04 + 0.02) = \pm 0.44A$$

$$\epsilon_{Meas}Voc = Voc (@STC) - VocNom = 37.1 - 37.3 = - 0.2V$$

$$\epsilon_{Meas}Isc = Isc (@STC) - IscNom = 10.53 - 13.88 = - 3.35A$$

Comparison conditions:

Voc Voltage $\rightarrow -1.9 + 1.7 \leq -0.2 \leq 1.9 - 1.7 \rightarrow$ Verified condition 1 \rightarrow **Outcome OK**

Isc Current $\rightarrow -1.39 + 0.44 \leq -3.35 \leq 1.39 - 0.44 \rightarrow$ Condition 1 NOT verified

Isc Current $\rightarrow -1.39 \leq -3.35 \leq 1.39 \rightarrow$ Condition 2 NOT verified

Isc Current $\rightarrow -1.39 - 0.44 \leq -3.35 \leq 1.39 + 0.44 \rightarrow$ Condition 3 NOT verified

Isc Current \rightarrow Verified condition 4 \rightarrow **Outcome NO OK**

6.8.8. Anomalous situations

1. In case the instrument detects a **voltage higher than 1000VDC** at terminals P-N, P-E and N-E, it does not carry out the test, gives out a long sound and displays the message “**V.Input > 1000VDC**”

IVCK	15/10 – 18:04			
Remote U. not active				
VPN	VPE	VNE		
0V	0V	0V		
V.Input >1000VDC				
1000V	1.00MΩ	2Ω	--- Ω	
VTest	ISO	RPE	>φ<	

2. In case the instrument detects a **voltage lower than - 0.5VDC** at terminals P-N, it does not carry out the test, gives out a long sound and displays the message “**Reverse P-N**”.

IVCK	15/10 – 18:04			
Remote U. not active				
VPN	VPE	VNE		
0V	0V	0V		
Reverse P-N				
1000V	1.00MΩ	2Ω	--- Ω	
VTest	ISO	RPE	>φ<	

3. In case the instrument detects a voltage - **$0.5V \leq VPN \leq 15VDC$** at terminals P-N, it does not carry out the test, gives out a long sound and displays the message “**V.Input < 15VDC**”.

IVCK	15/10 – 18:04			
Remote U. not active				
VPN	VPE	VNE		
11V	6V	-5V		
V.Input < 15VDC				
1000V	1.00MΩ	2Ω	--- Ω	
VTest	ISO	RPE	>φ<	

4. In case the instrument detects an AC voltage **higher than 10V** at terminals P-N, P-E and N-E, it does not carry out the test, gives out a long sound and displays the message “**V.Input > 10VAC**”.

IVCK	15/10 – 18:04			
Remote U. not active				
VPN	VPE	VNE		
11V	6V	-5V		
V.Input > 10VAC				
1000V	1.00MΩ	2Ω	--- Ω	
VTest	ISO	RPE	>φ<	

5. In case the instrument detects a **voltage >3V** at its terminals E and C, it does not carry out the test, gives out a long sound and displays the message “**V.Input > 3V**”.

IVCK	15/10 – 18:04		
Remote U. not active			
VPN	VPE	VNE	
0V	0V	0V	
V.Input > 3V			
1000V	1.00MΩ	2Ω	--- Ω
VTest	ISO	RPE	>φ<

6. In case the instrument detects a **current <0.1A** while measuring Isc current, the message to the side appears on the display. Check the connections of the instrument to the circuit being tested.

IVCK	15/10 – 18:04		
Remote U. not active			
VPN	VPE	VNE	
0V	0V	0V	
ISC < 0.1A			
1000V	1.00MΩ	2Ω	--- Ω
VTest	ISO	RPE	>φ<

7. In case the instrument detects a blown fuse while measuring Isc current, the message to the side appears on the display. Please contact HT’s After-sales Service.

IVCK	15/10 – 18:04		
Remote U. not active			
VPN	VPE	VNE	
0V	0V	0V	
Blown fuse			
1000V	1.00MΩ	2Ω	--- Ω
VTest	ISO	RPE	>φ<

8. In case no recording has been activated on remote unit SOLAR03, the message to the side is shown on the display. Check the status of the remote unit SOLAR03

IVCK	15/10 – 18:04		
Front			
Irr.	---	W/m2	
Temp.	---	°C	
SOLAR03 23051203			
Module: SUNPOWER318WTH			
VPN	VPE	VNE	
98.0V	490V	-490V	
Rem.Unit not connected			
1000V	1.00MΩ	2Ω	0.25Ω
VTest	ISO	RPE	>φ<

9. Once Voc and Isc measurements are completed, the message “**Waiting for irradiance values**” is shown in case a remote unit SOLAR03 is recording but not connected to the instrument. Wait for the remote unit to download the data to display the measurement results @STC

IVCK 15/10 – 18:04			
Voc@STC	---	V	
Isc@STC	---	A	
Voc Nom	985	V	
Isc Nom	11.25	A	
Rp	>100	MΩ	OK
R+	>100	R- >100 MΩ	
RPE	1.1	Ω	OK
Waiting for irradiance values			
1000V	1.00MΩ	2Ω	0.2 Ω
VTest	ISO	RPE	>φ<

10. In case the remote unit SOLAR03 has been activated and connected, but the irradiance value is not valid, the message to the side is shown on the display. Check the status of the remote unit

IVCK 15/10 – 18:04			
Irr.	---	W/m ²	
Temp.	---	°C	
SOLAR03	23051203	I	
Module:	318WTH		
VPN	VPE	VNE	
980 V	490 V	-490 V	
Check inputs of Rem.Unit			
1000V	1.00MΩ	2Ω	0.25Ω
VTest	ISO	RPE	>φ<

11. **In case measurements are carried out without remote unit** (see § 6.8.3), but the instrument has previously been paired to a remote unit, the message to the side appears on the display. Enter the remote unit’s configuration menu (see § 6.2) and select “**Unpair**” to unpair the remote unit.

IVCK 15/10 – 18:04			
Irr.	---	W/m ²	
Temp.	---	°C	
SOLAR03	23051203	I	
Module:	318WTH		
VPN	VPE	VNE	
980 V	490 V	-490 V	
Rem.Unit not connected			
1000V	1.00MΩ	2Ω	0.25Ω
VTest	ISO	RPE	>φ<

6.9. LIST OF ERROR MESSAGES ON THE DISPLAY

NUMBER	MESSAGE	DESCRIPTION	ACTIONS
1	Error EEPROM	Internal error	Send instrument for assistance
2	Error ADP5587		
3	Error System Init		
4	Vtest not correct	Resistive load too low in insulation	Rins control greater than the set limit and possible low battery level
5	Low battery	Low battery level	Replace batteries
6	Reverse P-N	P-N inputs reversed in the IVCK test	Check the connections indicated in the user manual
7	Forced exit	Forced interruption of the test with STOP key	Repeat the test without interrupting the measurement
8	V.Input > 1000VDC	Voltage too high between P and N inputs in IVCK test	Disconnect instrument and check the voltage between the P and N poles of the string
9	V.Input > 10VAC	AC voltage detected beyond limits between P and N inputs in IVCK test	Check if the string is disconnected from the inverter. Check whether the string connection cables are close to existing live cables. In this case, de-energize these cables and/or field panels
10	V.Input < 15VDC	Minimum voltage for IVCK test starts too low	Check if PV modules under test meet the minimum requirements indicated in the manual
11	V.Input > 3VDC	Voltage above limit detected between RPE function inputs	Check the connections as indicated in the user manual, check voltage between inputs E and C, update FW to the latest version
12	Zeroing NOT OK	Instrument does not perform tip calibration in RPE measurement	Check the continuity of the cables, check that they are regularly short-circuited and that they are original HT
13	Retry	Unreliable measured data	Repeat the measurement considering the user manual
14	Warning: Residual Volt.	Presence of voltage between the probes at the end of the ISO test due to high parasitic capacitances	Be careful when disconnecting the measurement terminals and follow the warnings in the user manual
15	Rcal > Rmeas	Test cable resistance reset procedure in RPE operation failed	Check the continuity of the cables, check that they are regularly short-circuited and that they are original HT
16	Flash Memory Error	Internal error	Send instrument for assistance
17	HOT	Internal circuit temperature too high	Waiting cooling circuits before performing new tests
18	lbatt too high	Internal error	Send instrument for assistance
19	VPN > Vtest	String voltage greater than test voltage in ISO test	Select a higher test voltage in the ISO test
20	Check wirings	Incorrect voltage detected in the P-N-E terminals	Check the connections indicated in the user manual
21	WiFi error	WiFi module does not respond to commands	Turn the instrument off and on again and try again. If the error persists, send the instrument for assistance
22	BT not work	Bluetooth module does not respond to commands	
23	Connection lost	Bluetooth module does not respond to commands	
24	IGBT damaged	Internal error	Send instrument for assistance
25	Remote U.: Low batt	SOLAR03 battery level low	Replace SOLAR03 batteries with others of the same type
26	Isc peak too high	Peak current too high due to high parasitic capacitances	Perform tests on the half string or tests on individual modules
27	Isc too high	Isc current >30A	Check the instrument connections, disconnect any strings in parallel and verify that the instrument is not connected to the PV inverter
28	Isc peak too long	Peak current too long maintained	
29	Check Remote U. Inputs	Values received from SOLAR03 are unrealistic	Check the SOLAR03 inputs and the position of the reference cells
30	Isc<0.1A	Isc measured value too low (<0.1A)	Check the connection cables and characteristics of the PV module considered
31	Irradiance < Lim.	Measured irradiance values lower than the set limit	Check the set limit and the position of the reference cells

7. STORING RESULTS

The instrument allows saving max 999 measured values. The saved data can be recalled at display and deleted at any moment and can be associated to reference numerical markers relevant to the installation (**max 3 levels**), the string and the PV module (**max 250**).

7.1. SAVING MEASURES

1. Press the **SAVE** key with a measured result shown on the display. The instrument shows the screen to the side, containing the following items:
 - The first memory location available (“Measure”)
 - 1st-level marker (e.g.: Plant). Up to 20 free custom different labels can be associated to each marker. Select the marker of the desired level with the arrow keys (◀, ▶) and press the **ENTER** key to select one of the available labels.
 - 2nd-level marker (e.g.: String). Up to 20 free custom different labels). Select the marker of the desired level with the arrow keys ◀, ▶.
 - 3rd-level marker (e.g.: Module). Up to 20 free custom different labels. Select the marker of the desired level with the arrow keys ◀, ▶.
 - The field “Comment” in which the operator can include a short description (max 30 char.) using the virtual keyboard. The entered comment is shown in the line underneath.

MEM	15/10 – 18:04	
Measure:		001
Plant		001
String		001
Module		- - -
Comment:		
Installation		
Smith		



CAUTION

- Custom names of marker labels can be defined **by using the TopView software** and uploaded onto the instrument through PC connection (section “Connection PC-Instrument → Marker management”)
- The names of the markers used in the measurements saved in memory cannot be deleted or modified
- The names of the default markers cannot be eliminated. Deletion of custom names can only occur through the **TopView software**.

2. Press the **SAVE** key again to confirm data saving or **ESC/MENU** to exit without saving.

7.2. RECALLING AND DELETION OF SAVED DATA

- Press the **ESC/MENU** key to go back to the main menu, select "**MEM**" and confirm with **ENTER** to access the section where saved values are displayed. The screen to the side is shown by the instrument and contains the list of saved tests.
- Use the arrow keys **▲, ▼** to select the saved measure which is to be shown on the display, and use the arrow keys **◀, ▶** to select "**Rec**". Confirm with **ENTER**. The following screen appears on the display:

MEM 15/10 – 18:04		
N.	Date	Type
001	15/05/23	RPE
002	15/05/23	MΩ
003	15/05/23	IVCK
004	12/04/23	RPE
005	12/04/23	IVCK
Tot: 5		Free: 994
▲		▼
Last		
Rec	Pag	Delete

- For **IVCK** test, there are the values of the following parameters:
 - Voc @STC voltage value with relative outcome
 - Isc @STC current value with relative outcome
 - Voc nominal value
 - Isc nominal value
 - Rp value with relative outcome (if test selected) otherwise indication "- - -" if test not selected (OFF)
 - R+ and R- values with related results (if test selected) otherwise indication "- - -" if test not selected (OFF)
 - RPE value with relative outcome (if test selected) otherwise indication "- - -" if test not selected (OFF)

IVCK 15/10 – 18:04			
Voc@STC	43.0	V	OK
Isc@STC	1.76	A	OK
Voc Nom	42.9	V	
Isc Nom	1.80	A	
Rp	---	MΩ	
R+	---	R-	---
RPE	---		Ω
OK			
OFF	OFF	OFF	--- Ω
VTest	ISO	RPE	>φ<

- Use the **◀, ▶** arrow keys to select values **@OPC**. The screen to the side is shown on the display

IVCK 15/10 – 18:04			
Voc@OPC	985	V	
Isc@OPC	1.77	A	
VocMed	985	V	
IscMed	1.81	A	
Rp	---	MΩ	
R+	---	R-	---
RPE	---		Ω
OK			
OFF	OFF	OFF	--- Ω
VTest	ISO	RPE	>φ<

- Use the **◀, ▶** arrow keys to select the values of **Irradiation** and **PV module Temperature**. The screen on the side is shown on the display
- Use the **▲, ▼** arrow keys to quickly move to the next or previous measurement within the list of saved measurements

IVCK 15/10 – 18:04				
Irr.	Front	Btop	Bbot.	W/m2
	920	125	95	
Temp	54.7			°C
Rp			>100	MΩ OK
R+	>100	R-	>100	MΩ
RPE				Ω
OK				
1000V	1.00MΩ	OFF	---	Ω
VTest	ISO	RPE		>φ<

7. For **RPE** test, there are the values of the following parameters:

- Limit threshold set for continuity measurement
- Value of calibration resistance of test cables
- The value of resistance of the object being tested
- The real value of the applied test current
- Measured result

RPE		15/10 – 18:04		
R	0.02	Ω		
I _{test}	212	mA		
OK				
STD	2.00 Ω	0.06 Ω		
MODE	Lim.		> ϕ <	

8. Use the arrow keys **▲**, **▼** to select the saved measure which is to be deleted, and use the arrow keys **◀**, **▶** to select “**Del**”. Confirm with **ENTER**. The following screen appears on the display:

MEM		15/10 – 18:04		
N.	Date	Type		
001	15/05/23	RPE		
002	15/05/23	M Ω		
003	15/05/23	IVCK		
004	12/04/23	RPE		
005	12/04/23	IVCK		
Tot: 5		Free: 994		
▲	▲	Last		
▼	▼			
Rec	Pag	Delete		

9. Press the **ENTER** key to confirm and the **ESC** key to exit without confirming and to go back to the main menu. **The instrument always deletes the last saved measure**

MEM		15/10 – 18:04		
DELETE LAST?				
ENTER / ESC				

8. CONNECTING THE INSTRUMENT TO THE PC

The connection between a PC and the instrument can be done via an optical serial port (see Fig. 3) by means of the optical/USB cable C2006, or via WiFi connection. The choice of the type of connection must be done via the management software **TopView** freely downloadable from the HT website starting from the link: <https://www.ht-instruments.com/en/product-download/>



CAUTION

- In order to transfer the data onto a PC through an optical/USB cable, it is necessary to install the management software on the PC itself beforehand.
- Before connecting, it is necessary to select the port to be used and the correct baud rate (57600 bps) on the PC. To set these parameters, launch the management software provided and refer to the program's on-line help.
- The selected port must not be engaged by other devices or applications, e.g. a mouse, a modem, etc. Close any applications running using the Microsoft Windows Task Manager function, if necessary.
- The optical port emits invisible LED radiations. Do not directly observe with optical instruments. Class 1M LED apparatus according to standard IEC/EN 60825-1.

To transfer data to the PC, follow this procedure:

1. Switch on the instrument by pressing the **ON/OFF** key.
2. Connect the instrument to the PC via the provided optical/USB cable **C2006**.
3. Use the arrow keys (**▲**, **▼**) to select "**PC**", to access data transfer mode and confirm with **SAVE/ENTER**.

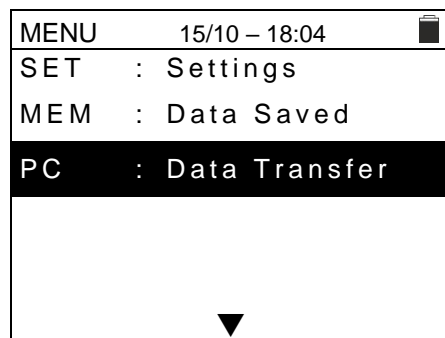

4. If using the WiFi connection is necessary, activate the internal module (see § 5.1.3). The instrument shows the following screen:

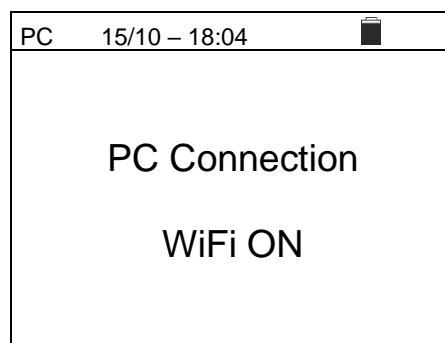

6. Use the software controls to activate data transfer (please refer to the on-line help of the program).

9. MAINTENANCE

9.1. GENERAL INFORMATION

The instrument you purchased is a precision instrument. While using and storing the instrument, carefully observe the recommendations listed in this manual in order to prevent possible damage or danger during use.

Do not use the instrument in environments with high humidity levels or high temperatures. Do not expose to direct sunlight.

Always switch off the instrument after use. In case the instrument is not to be used for a long time, remove the batteries to avoid liquid leaks that could damage the instrument's internal circuits.

9.2. BATTERY REPLACEMENT

When the low battery symbol “” appears on the LCD display, or if during a test the instrument shows the message “low battery”, it is necessary to replace the internal batteries.



CAUTION

Only expert and trained technicians should perform this operation. Before carrying out this operation, make sure you have disconnected all cables from the input terminals.

1. Switch off the instrument by pressing and holding the **ON/OFF** key.
2. Remove the cables from the inputs.
3. Loosen the battery compartment cover fastening screw and remove the cover.
4. Remove all the batteries from the battery compartment and replace them with new batteries of the same type only (see § 0), making sure to respect the indicated polarities.
5. Restore the battery compartment cover into place and fasten it by means of the relevant screw.
6. Do not scatter old batteries into the environment. Use the relevant containers for disposal.

9.3. CLEANING THE INSTRUMENT

Use a soft and dry cloth to clean the instrument. Never use wet cloths, solvents, water, etc.

9.4. END OF LIFE



CAUTION: this symbol indicates that the appliance, its accessories, and the internal batteries must be collected separately and correctly disposed of.

10. TECHNICAL SPECIFICATIONS

10.1. TECHNICAL CHARACTERISTICS

Accuracy is indicated as $\pm[\% \text{reading} + (\text{num. dgt} \times \text{resolution})]$ at $23^\circ\text{C} \pm 5^\circ\text{C}$, $< 80\% \text{RH}$

ELECTRICAL SAFETY

DMM – DC Voltage

Range [V]	Resolution [V]	Accuracy
3 ÷ 1000	1	$\pm(1.0\% \text{rdg} + 2 \text{dgt})$

DMM – AC TRMS Voltage

Range [V]	Resolution [V]	Accuracy
3 ÷ 1000	1	$\pm(1.0\% \text{rdg} + 3 \text{dgt})$

Frequency range: $42.5 \div 69 \text{Hz}$; Voltages zeroed for measured value $< 3 \text{V}$

MΩ - Insulation resistance R(+), R(-), Rp – DUAL Mode

Test voltage DC [V]	Range [MΩ]	Resolution [MΩ]	Accuracy (*)
250, 500, 1000	0.1 ÷ 0.99	0.01	$\pm(5.0\% \text{rdg} + 5 \text{dgt})$
	1.0 ÷ 19.9	0.1	
	20 ÷ 100	1	

(*) Accuracy declared for $\text{VPN} \geq 240 \text{V}$, $\text{R}_{\text{fault}} \geq 10 \text{M}\Omega$; Accuracy of R_p and $R(+)$ not declared if $R(+)$ $\geq 0.2 \text{M}\Omega$ and $R(-)$ $< 0.2 \text{M}\Omega$ →, Accuracy of R_p and $R(-)$ not declared if $R(+)$ $< 0.2 \text{M}\Omega$ and $R(-)$ $\geq 0.2 \text{M}\Omega$.

Open circuit voltage $< 1.25 \times$ rated test voltage
 Short-circuit current $< 15 \text{mA}$ (peak) for each test voltage
 Rated test current $> 1 \text{mA}$ on $R = 1 \text{k}\Omega \times V_{\text{nom}}$ (with VPN, VPE, VNE= 0)
 Managed capacity per poles: $2 \mu\text{F}$

Insulation resistance (MΩ) – TMR mode

Test voltage DC [V]	Range [MΩ]	Resolution [MΩ]	Accuracy
250, 500, 1000	0.01 ÷ 9.99	0.01	$\pm(5.0\% \text{rdg} + 5 \text{dgt})$
	10.0 ÷ 99.9	0.1	
	100 ÷ 250	1	

Open circuit voltage $< 1.25 \times$ rated test voltage
 Short-circuit current $< 15 \text{mA}$ (peak) for each test voltage
 Rated test current $> 1 \text{mA}$ on $R = 1 \text{k}\Omega \times V_{\text{nom}}$ (with VPN, VPE, VNE= 0)
 Selectable Timer: $3 \text{s} \div 999 \text{s}$

Continuity of protective conductors (RPE)

Range [Ω]	Resolution [Ω]	Accuracy
0.00 ÷ 9.99	0.01	$\pm(2.0\% \text{rdg} + 2 \text{dgt})$
10.0 ÷ 99.9	0.1	
100 ÷ 1999	1	

Test current: $> 200 \text{mA}$ DC up to 5Ω (cables included), resolution 1mA , accuracy $\pm(5.0\% \text{reading} + 5 \text{digits})$
 Open-circuit voltage $4 < V_0 < 10 \text{V}$

GFL– Ground Fault Locator

Test voltage DC [V]	Range [MΩ]	Resolution [MΩ]	Accuracy Rp(*)	Accuracy Position
250,500,1000	0.1 ÷ 0.99	0.01	$\pm(5.0\% \text{rdg} + 5 \text{dgt})$	$\pm 1 \text{mod. (NMOD} \leq 34)$ $\pm 3 \text{mod. (NMOD} > 34)$
	1.0 ÷ 19.9	0.1		
	20 ÷ 100	1		

(*) Accuracy declared for $\text{VPN} \geq 240 \text{V}$, $\text{R}_{\text{fault}} \geq 10 \text{M}\Omega$; Accuracy of R_p and $R(+)$ not declared if $R(+)$ $\geq 0.2 \text{M}\Omega$ and $R(-)$ $< 0.2 \text{M}\Omega$ →, Accuracy of R_p and $R(-)$ not declared if $R(+)$ $< 0.2 \text{M}\Omega$ and $R(-)$ $\geq 0.2 \text{M}\Omega$.

Open circuit voltage $< 1.25 \times$ rated test voltage
 Short-circuit current $< 15 \text{mA}$ (peak) for each test voltage
 Rated test current $> 1 \text{mA}$ on $R = 1 \text{k}\Omega \times V_{\text{nom}}$ (with VPN, VPE, VNE= 0)
 Managed capacity per poles: $2 \mu\text{F}$
 Measuring limit: $0.05 \text{M}\Omega$, $0.1 \text{M}\Omega$, $0.23 \text{M}\Omega$, $0.25 \text{M}\Omega$, $0.50 \text{M}\Omega$, $1.00 \text{M}\Omega$
 Number of modules (NMOD): $4 \div 60$

The GFL function provides correct results with the following conditions:

- Test carried out with $V_{\text{test}} \geq V_{\text{nom}}$ on a **single string** disconnected from inverter, from overvoltage protections and earth connections.
- Test carried out upstream of possible blocking diodes
- **Single fault** of low insulation located at any position in the string
- Insulation resistance of the single fault: $< 1.00 \text{M}\Omega$
- Environmental conditions similar to those in which the fault occurred

OPT – Insulation test with optimizers and MLPE devices

Test voltage DC [V]	Range [MΩ]	Resolution [MΩ]	Accuracy Rp(*)
100, 250, 500,1000 (MLPE with RSD)	0.1 ÷ 0.99	0.01	±(5.0%rdg + 10dgt)
	1.0 ÷ 19.9	0.1	
	20 ÷ 250	1	
100 (MLPE without RSD)	0.1 ÷ 0.99	0.01	
	1.0 ÷ 19.9	0.1	
	20 ÷ 100	1	

(*) Accuracy declared for $VPN \geq 240V$, $R_{fault} \geq 10\Omega$; Accuracy of R_p and $R(+)$ not declared if $R(+)\geq 0.2M\Omega$ and $R(-)<0.2M\Omega$ →, Accuracy of R_p and $R(-)$ not declared if $R(+)<0.2M\Omega$ and $R(-)\geq 0.2M\Omega$.

Open circuit voltage	<1.25 x rated test voltage
Short-circuit current	<15mA (peak) for each test voltage
Rated test current	> 1mA on R = 1kΩ x Vnom (with VPN, VPE, VNE= 0)
Managed capacity per poles:	2μF
Measuring limit:	0.10MΩ, 0.25MΩ, 0.60MΩ, 1.00MΩ, 100MΩ, 200MΩ (MLPE with RSD) 0.10MΩ, 0.25MΩ, 0.60MΩ, 1.00MΩ, 50MΩ (MLPE without RSD)
Number optimizers:	1 ÷ 60
Max current in RSD mode:	1A

IVCK FUNCTION

Accuracy is indicated as ±[%reading + (number of digits*resolution)] at 23°C±5°C, <80%RH

DC Voltage @ OPC

Range [V]	Resolution [V]	Accuracy
3.0 ÷ 1000.0	0.1	±(1.0%rdg + 2dgt)

Minimum VPN voltage to start the test: 15V; With Start&Save function active, the minimum VPN voltage is 30V

DC Current @ OPC

Range [A]	Resolution [A]	Accuracy
0.10 ÷ 30.00	0.01	±(1.0%rdg + 2dgt)

DC Voltage @ STC

Range [V]	Resolution [V]	Accuracy
3.0 ÷ 1000.0	0.1	±(4.0%rdg + 2dgt)

DC Current @ STC

Range [A]	Resolution [A]	Accuracy
0.10 ÷ 30.00	0.01	±(4.0%rdg + 2dgt)

Irradiation with connection to HT305 reference cell

Voltage range [mV]	Resolution [mV]	Accuracy (*)
0.00 ÷ 99.99	0.01	±(1.0%rdg + 0.02mV)

Measurement range [W/m ²]	Resolution [W/m ²]	Accuracy (*)
0 ÷ 1400	1	±(1.0%rdg + 1dgt)

(*) Accuracy of instrument without cell

Module temperature with connection to PT305 probe

Resistance range [Ω]	Resolution [Ω]	Accuracy (*)
846 ÷ 1385	0.385	±(1.0%rdg + 3.85Ω)

Measurement range [°C]	Resolution [°C]	Accuracy (*)
-40.0 ÷ 99.9	0.1	±(1.0%rdg + 1°C)

(*) Accuracy of instrument without probe

10.2. GENERAL CHARACTERISTICS

Reference guidelines

Instrument safety:	IEC/EN61010-1, IEC/EN61010-2-030 IEC/EN61010-2-033, IEC/EN61010-2-034
EMC:	IEC/EN61326-1, IEC/EN61326-2-2
Safety of measuring accessories:	IEC/EN61010-031
Measurements:	IEC/EN62446-1, IEC/EN60891 (IVCK) IEC/EN61557-1-10, IEC/EN61557-2 (MΩ) IEC/EN61557-4 (RPE)
Bifacial module measurements :	IEC/EN60904-1-2
Temperature module calculation :	IEC/EN60904-5
EMC environment of use :	portable, Class A, Group 1
Insulation:	double insulation
Pollution level:	2
Measurement category:	CAT III 1000V to earth, Max 1000VAC, 1000VDC between inputs

Radio

Compliance with RED directive :	ETSI EN300328, ETSI EN301489-1, ETSI EN301489-17
---------------------------------	---

Display, memory and PC interface

Type of display:	LCD custom, 240x240pxl, with backlight
Saved data:	max 999, 3 marker levels
Internal database:	max 64 modules
PC interface:	optical/USB and WiFi
Interface with SOLAR03:	Bluetooth connection (up to 100m/328ft in free space)

Power supply

Battery type:	6x1.5V alkaline type AA LR06 or 6x1.2V rechargeable batteries NiMH type AA LR06
Low battery indication:	symbol "☐" on the display
Battery duration (@Temp = 20°C):	RPE: >500 Tests (RPE ≥ 0.1Ω) GFL, MΩ: >500 tests (Riso ≥ 1kΩxVTest) IVCK: >500 tests (no SOLAR03)
Auto power off:	after 5 minutes' idling

Mechanical characteristics

Dimensions (L x W x H)	235 x 165 x 75mm (9 x 6 x 3in)
Weight (batteries included):	1.2kg (25lv)
Mechanical protection:	IP40

10.3. ENVIRONMENTAL CONDITIONS FOR USE

Reference temperature:	23°C ± 5°C (73°F ± 41°F)
Operating temperature:	-10°C ÷ 50°C (14°F ± 122°F)
Allowable relative humidity:	<80%RH (without condensation)
Storage temperature:	-10°C ÷ 60°C (14°F ± 140°F)
Storage humidity:	<80%RH (without condensation)
Max operating altitude:	2000m (6562ft)

**This instrument satisfies the requirements of Low Voltage Directive 2014/35/EU (LVD) and of Directive 2014/30/EU (EMC) and RED 2014/53/EU
This instrument satisfies the requirements of European Directive 2011/65/EU (RoHS) and 2012/19/EU (WEEE)**

10.4. ACCESSORIES

See the attached packing list

**CAUTION**

Only the accessories provided together with the instrument will guarantee safety standards. They must be in good conditions and replaced with identical models, when necessary

11. APPENDIX – THEORETICAL OUTLINE

11.1. MEASUREMENT OF POLARIZATION INDEX (PI)

The purpose of this diagnostic test is to evaluate the influence of the polarization effects. Upon the application of a high voltage to insulation, the electric dipoles distributed in the insulation align in the direction of the applied electric field. This phenomenon is called polarization. Because of the polarized molecules, a polarization (absorption) current generates, which lowers the total value of insulation resistance.

Parameter **PI** consists in the ratio between the value of insulation resistance measured after 1 minute and after 10 minutes. The test voltage is maintained throughout the whole duration of the test and, at the end, the instrument provides the value of ratio:

$$PI = \frac{R (10 \text{ min})}{R (1 \text{ min})}$$

Some reference values:

PI Value	Insulation condition
<1.0	Not acceptable
from 1.0 to 2.0	Dangerous
from 2.0 to 4.0	Good
> 4.0	Excellent

11.2. DIELECTRIC ABSORPTION RATIO (DAR)

Parameter **DAR** consists in the ratio between the value of insulation resistance measured after 30s and after 1 minute. The test voltage is maintained throughout the whole duration of the test and, at the end, the instrument provides the value of ratio:

$$DAR = \frac{R (1 \text{ min})}{R (30s)}$$

Some reference values:

DAR Value	Insulation condition
< 1.0	Not acceptable
from 1.0 to 1.25	Dangerous
from 1.25 to 1.6	Good
> 1.6	Excellent

11.3. GFL FUNCTION – THEORETICAL ASPECTS AND REFERENCES GUIDELINES

The GFL function performed by the instrument on a string of PV modules (see § 6.5) is capable of:

- Identify the presence of a **single fault** on the string disconnected from the inverter, from other strings, from any arresters and from functional earth connections
- Identify the position of this **single fault** within the string by setting a **minimum** limit in the insulation resistance control between the options: **0.05MΩ**, **0.1MΩ**, **0.23MΩ**, **0.25MΩ**, **0.50MΩ** or **1.00MΩ**

In the field of insulation measurement, there is a “contrast” between the regulations for the verification of photovoltaic installations (IEC/EN62446-1) and the product regulations with which the PV modules are built (IEC 61646 and IEC 61215) which define the following verification limits

- IEC/EN62446-1 → minimum insulation limit = **1MΩ**
- IEC 61646/IEC61215 → minimum insulation of a single module equal to **40MΩ/m²** therefore for a typical module of approximately 2m² → minimum insulation of approximately **20MΩ**. Therefore, a single PV module with earth insulation of **20MΩ** is to be considered as a module that complies with the type tests, i.e. "not faulty".

To fix ideas on the situation present in the field, we refer to the followed example (see Fig. 17): let's consider a string made up of **31 PV modules**, each with an insulation to earth of 20MΩ. The "overall" insulation of the string is therefore given by the parallel of the 31 resistors, i.e. $20\text{M}\Omega/31 = \mathbf{0.64\text{M}\Omega}$

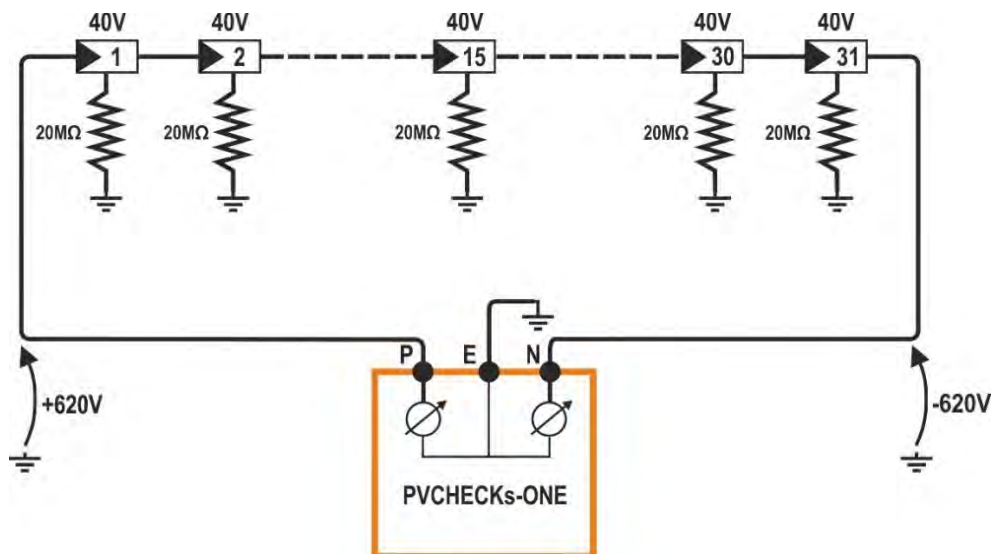

Fig. 17: Example of using the GFL function

This insulation value, measured by the PVCHECKS-ONE instrument, would be acceptable according to the product standards of PV modules, but is however in contrast with the IEC/EN62446-1 verification standard which provides for a minimum insulation of **1MΩ**

This regulatory "difference" is known to inverter manufacturers who in fact make the minimum value allowed for insulation (normally) settable and suggest approximately 100kΩ = 0.1MΩ as the value below which the inverter locks out (this value depends on the manufacturers, for example SMA "suggests" 200kΩ)

If it were decided to accept a minimum limit value of 1MΩ, **this would make fault localization critical**

In fact, in the example previously reported, since none of the PV modules is actually faulty, the potentials of the positive and negative poles are substantially symmetrical with respect to earth (+620V and -620V) therefore the instrument would erroneously detect a "fault" in a module with resistance insulation equal to $0.64\text{M}\Omega$, whose position is calculated as follows (in compliance with the requirements of IEC/EN62446-1)

Fault position = V_T / V_{mod}

where:

- V_T = **minimum value between VPE and VEN voltage**
- V_{mod} = voltage of a single module

→ Fault position = $620 / 40 = 15.5$ (close the 15th module of the string)

The before mentioned module, by hypothesis, is not faulty at all and, tested individually, would present, like all the other modules, a correct insulation to earth equal to $20\text{M}\Omega$

In this case, for example by setting a minimum insulation limit equal to $230\text{k}\Omega = 0.23\text{M}\Omega$, it can be considered a **represents the maximum reasonable value that allows us to assume the presence of an actual SINGLE insulation fault towards earth** (which is the main hypothesis on which it is based the procedure indicated by the IEC/EN62446-1 standard to which the GFL function of the PVCHECKs-ONE instrument complies.

11.4. DUAL AND TMR FUNCTIONS – TECHNICAL INSIGHTS

The DUAL and TMR functions are the two modes in which the PVCHECKs-ONE instrument carries out insulation measurements on PV installations. In particular:

- **DUAL mode** → allows to perform insulation measurement on single modules, on single strings, on strings in parallel and on entire PV fields by operating on the (+) and (-) poles of the same, **without the need to connect them in short circuit**. The function guarantees a drastic reduction in test times, flexibility, and immediate confirmation of the insulation status of both polarities, but on the other hand **it must always recognize the presence of a voltage between the positive and negative poles $V_{PN} > 15VDC$** in order to perform the test → this means that this function **CANNOT be used directly in the presence of power optimizers** (unless they are disconnected beforehand) as they would drastically lower the string voltage
- **TMR mode** → allows to perform the "typical" insulation measurement between the (-) pole and/or the (+) pole of the PV module/string/field to earth, test insulation of connection cables, parts of the inverter, safety electricity in general according to safety standards **in a continuous manner by setting a measurement timer in the range 3s ÷ 999s** without **any voltage constraint necessarily present between the poles** (as happens instead in the DUAL mode) → The method necessarily requires carrying out more than one measures on strings, **but is usable in the presence of power optimizers**

11.4.1. Regulatory and theoretical aspects of insulation measurement

The IEC/EN62446-1 guideline indicates that the insulation measurement of the circuits associated with a PV system (single modules, strings, PV fields, connections, etc...) must be carried out, always **evaluating the minimum resistance value**, in one of the following methods:

1. Measurement of insulation resistance to earth of the positive and negative poles of PV modules/strings/fields (**method used in the TMR mode and more accurately in the DUAL mode of PVCHECKs-ONE, PVCHECKs-PRO and PV-ISOTEST**)
2. Measurement of the insulation resistance to earth of the positive and negative poles previously short-circuited together (**method used by the PVCHECKs model**)

Method 1

Even if PV systems are essentially created as **IT systems** (therefore not having a physically created earth system), random disturbance voltages due to "parasitic" parameters are always present between the (+) / earth and (-) / earth poles (typically ohmic capacitive effects) indicated as **Vop** and **Von** in the following principle diagram (see Fig. 18 - left part):

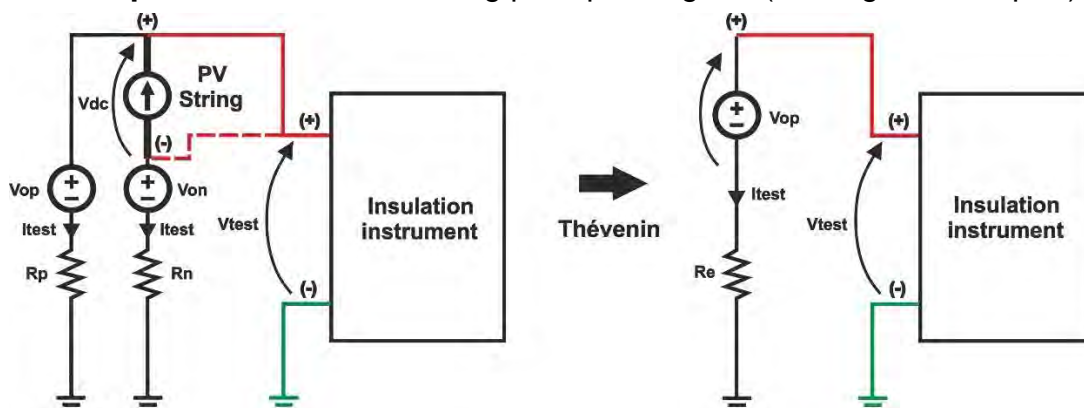

Fig. 18: Diagram and equivalent circuit of Method 1

In which:

- V_{test} = test voltage of insulation meter
- I_{test} = test current delivered as a result of the applied test voltage
- V_{dc} = string voltage
- R_p = insulation resistance of the (+) pole to earth
- R_n = insulation resistance of the (-) pole to earth
- V_{op} = random “parasitic” voltage from the (+) pole to ground
- V_{on} = random “parasitic” voltage from the (-) pole to ground

The disturbance voltages V_{op} and V_{on} depend on several factors including the string voltage, the environmental conditions and the presence of the instrument itself and can significantly influence the insulation measurement.

By applying the simplification rule according to Thévenin it is possible to refer to the correspondent equivalent circuit (see Fig. 18 - right part), referring for example to the (+) pole of the string

In which:

$$R_e = R_p // R_n = \frac{R_p * R_n}{R_p + R_n} ; I_{test} = \frac{(V_{test} - V_{op})}{R_e} ; V_{op} = V_{dc} \frac{R_p}{R_p + R_n}$$

Consider the following example:

- $V_{test} = 500VDC$
- $R_p = 10M\Omega \rightarrow$ Insulation supposedly correct ($>1M\Omega$) on (+) pole
- $R_n = 0.1M\Omega \rightarrow$ Insulation supposedly incorrect ($<1M\Omega$) on (-) pole
- $V_{dc} = 490VDC$
- $V_{op} \cong 490V$
- $R_e \cong 0.1M\Omega$
- $I_{test} \cong 100\mu A$

The insulation meter (TMR mode) measures V_{test} and I_{test} and calculates the following insulation resistance instead:

$$R_{eEFF} = \frac{V_{test}}{I_{test}} = \frac{500V}{100\mu A} = 5M\Omega$$

Therefore, due to the presence of V_{op} , despite having low insulation on the (-) pole, the instrument provides a **NOT correct** value of good insulation in the measurement performed on the (+) pole \rightarrow **the measurement with Method 1 may therefore be affected by an error which depends on the magnitude of the disturbance voltages**

The DUAL mode (**currently present only on HT instruments**) always falls into the type of Method 1, but uses more complex calculation equations (not based on the simple Ohm's Law) which take into account the effects of disturbance voltages, it is **NOT affected by these errors** and always provides in the same time the following correctly information:

- Insulation resistance of the R (+) pole to earth
- Insulation resistance of the R (-) pole to earth
- Resistance **$R_p = R (+) // R (-)$** of the parallel between the insulation resistances of the two poles which is used as a reference value for comparison with the minimum limit value (typically $1M\Omega$)

Method 2

This method (see Fig. 19) involves short-circuiting (using a special safety device) the two poles (+) and (-) in order to **zeroed the disturbance voltage V_o** and then carry out an insulation resistance measurement « classical" between the common point of the short-circuited poles and earth

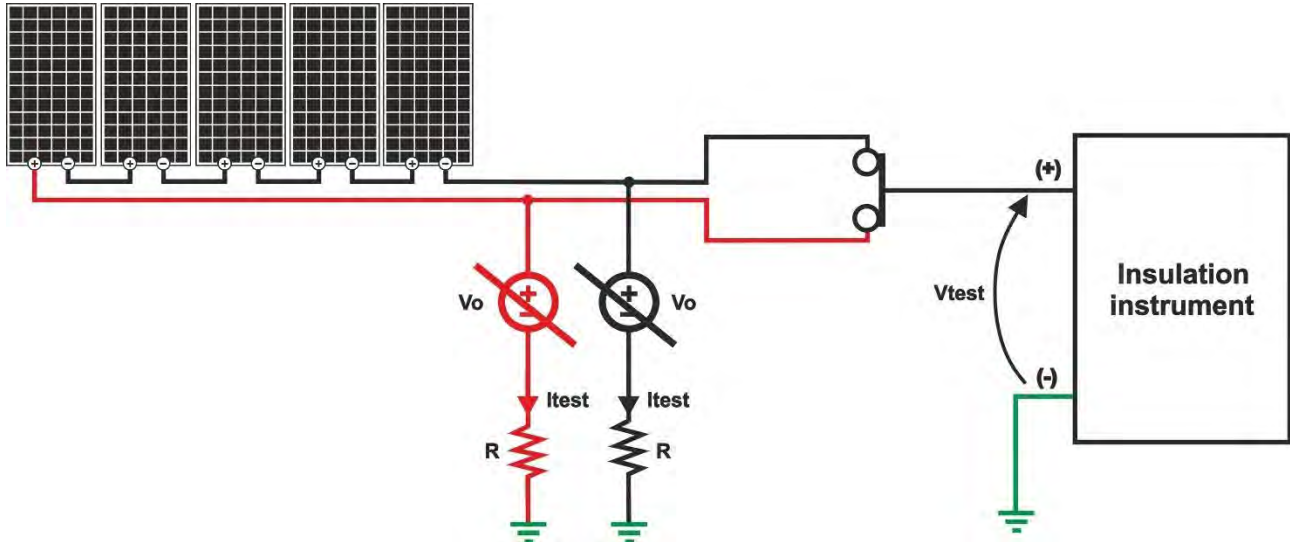

Fig. 19: Diagram and equivalent circuit of Method 2

The disadvantages of this method (used by the PVCHECKs model which automatically shorts the string poles internally) are as follows:

- The insulation resistances of the two poles are in parallel → the instrument always performs and provides only the measurement of this R_p , therefore, **it is not possible** to highlight the pole in which there is a low insulation problem
- It is possible to test **ONLY** one string at a time in order not to reach too high short-circuit current values which could damage the instrument (max 15A for PVCHECKs)

11.5. MLPE GENERAL CHARACTERISTICS (OPTIMIZERS AND RSD DEVICES)

The Module Level Power Electronics (MLPE) devices, including microinverters, DC optimizers, and rapid shutdown devices (RSD), are designed to improve both the energy yield and safety of individual PV modules. Microinverters and DC optimizers electrically decouple each module from the string, enabling completely independent operation and maximizing energy production under uneven or misaligned irradiance conditions. These devices also enable a detailed module-level monitoring

11.5.1. Features of RSD devices

The **RSD = Rapid ShutDown** devices are primarily safety components. They de-energize module conductors in an emergency to meet the requirements of firefighting and rapid shutdown systems, providing valuable support to operators in the event of danger (e.g., firefighters). While they act as module-level disconnect switches, they do not offer performance optimization or monitoring capabilities.

11.5.2. General characteristics of power optimizers

In the photovoltaic sector, the primary purpose of power optimizers is to maximize the energy production of each individual module, independently of the others, mitigating the effects of shading, mismatch, and aging. This results in an overall increase in system energy yield, greater installation flexibility, and improved system management and safety. Each optimizer is connected to a single module (or a small group of modules) and independently manages its own power. Without optimizers, if one panel experiences shading or underperformance, it limits the current of the entire series-connected string. With optimizers, each panel continues to operate at its maximum potential even when other modules exhibit performance issues.

In order to fix the ideas, if, for example, we consider a series of PV modules and **one of them is underperforming, the current of the entire string is limited**. Using a hydraulic analogy, the underperforming module could be thought of as a constriction in a pipe that limits the flow of current through the conduit. If optimizers are also installed on each PV module, and on the faulty one, the current that cannot pass through the module with lower performance **is bypassed by the optimizer**. Again, using the hydraulic analogy, it is as if there were an auxiliary bypass pipe that conveys the flow that cannot pass through the constriction in the main pipe. Based on the previous description, a string of PV modules including optimizers can be electrically schematized as shown in Fig. 20

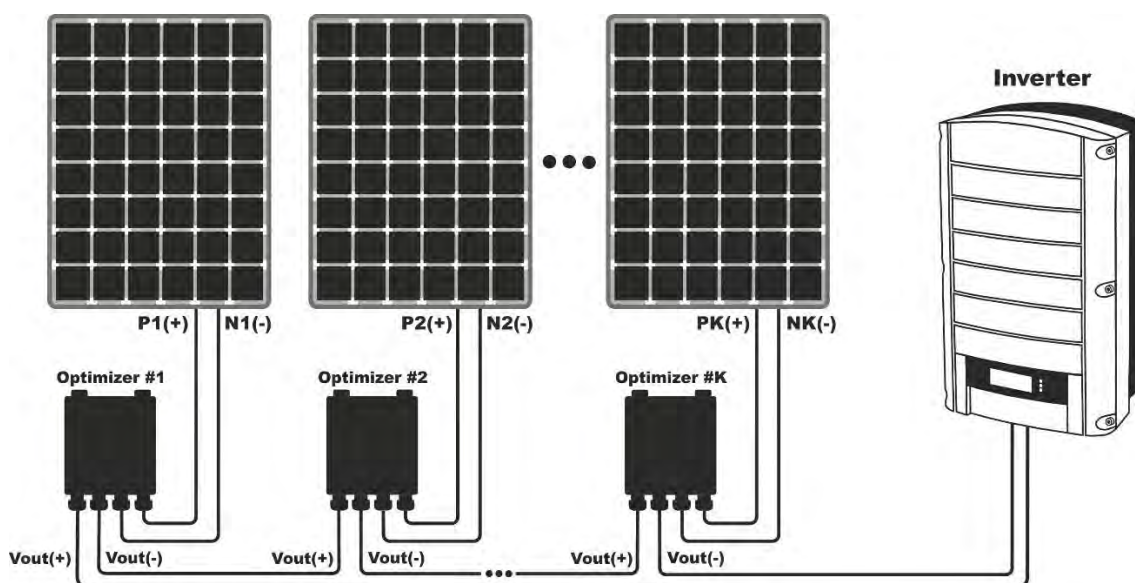

Fig. 20: Connecting a PV string with power optimizers included

11.5.3. IVCK or I-V curve test on MLPE devices

Based on the operating principles of MLPE devices, performing IVCK or I-V curve tests on PV strings incorporating microinverters or DC optimizers is not only unnecessary **but also technically inappropriate**. These systems electrically decouple each module from the string, preventing any meaningful characterization of I-V curves or Isc measurements at the string level. **Performing these tests can risk damaging both the MLPE devices and the test instrument.**

11.5.4. Insulation measurement on MLPE devices (OPT function)

Referring to the diagram in 20, if an inverter connected to a PV string composed of a series of optimizers, **blocks due to low insulation to ground**, the possible causes (excluding problems at the inverter) could be the following:

1. One or more PV modules has a ground fault
2. One or more optimizers has a ground fault

In general, therefore, for an inverter connected to a combiner box in which one of the strings (equipped with optimizers) presents low insulation problems, it is possible to proceed with the measurement **string by string**. Once the string with low insulation has been identified, you can proceed to locate the module(s) and optimizers with leakage by dividing it into sub-sections.

Since one of the optimizer's two poles is electrically "pass-through," both low insulation within the optimizer itself and low insulation in the associated PV module could occur. Therefore, to determine whether the insulation fault originates in the PV module or the optimizer, **it is necessary to disconnect them and test each component separately.**

11.5.5. Types of isolation measurements with power optimizers

The insulation measurement depends essentially on the type of optimizer installed. Specifically, two families of optimizers can be distinguished:

- Power optimizers with the "**rapid shutdown**" function → **RSD = Rapid ShutDown**
- Power optimizers **NOT with the RSD function**

Power optimizers and "rapid shutdown" are two essential components of modern photovoltaic systems. Devices equipped with this function **automatically reduce the output voltage close to zero** under certain conditions, including disconnection of the string from the inverter. This combination improves safety **for emergency responders** (e.g., firefighters) to ensure compliance with relevant regulations. Major manufacturers offer optimizers that include the RSD function, and some offer models with or without the function, or models that can only be activated by the respective inverter.

The RSD function is regulated by the US **NEC 690.12** guideline which requires that the total voltage across the string made up of the optimizers must be maintained **less than 30V** within **30s** of the various fault conditions including the case of the disconnected string.

In terms of insulation testing, the presence/absence of the RSD function modify the type of test that can be performed as:

- **With RSD devices present** → in this case the output voltage is practically zero, therefore it is possible to short-circuit the output poles of the optimizer string
- **With RSD devices not present** → the output voltage of the optimizer string is essentially equal to the total string voltage of the PV modules → in this case **it is not possible to short-circuit the poles for the entire time required to perform the insulation measurement (approximately 10s)**

12. ASSISTANCE

12.1. WARRANTY CONDITIONS

This instrument is warranted against any material or manufacturing defect, in compliance with the general sales conditions. During the warranty period, defective parts may be replaced. However, the manufacturer reserves the right to repair or replace the product. Should the instrument be returned to the After-sales Service or to a Dealer, transport will be at the Customer's charge. However, shipment will be agreed in advance. A report will always be enclosed to a shipment, stating the reasons for the product's return. Only use original packaging for shipment; any damage due to the use of non-original packaging material will be charged to the Customer. The manufacturer declines any responsibility for injury to people or damage to property.

The warranty shall not apply in the following cases:

- Repair and/or replacement of accessories and battery (not covered by warranty).
- Repairs that may become necessary because of an incorrect use of the instrument or due to its use together with non-compatible appliances.
- Repairs that may become necessary because of improper packaging.
- Repairs which may become necessary because of interventions performed by unauthorized personnel.
- Modifications to the instrument performed without the manufacturer's explicit authorization.
- Use not provided for in the instrument's specifications or in the instruction manual.

The content of this manual cannot be reproduced in any form without the manufacturer's authorization.

Our products are patented and our trademarks are registered. The manufacturer reserves the right to make changes in the specifications and prices if this is due to improvements in technology.

12.2. ASSISTANCE

If the instrument does not operate properly, before contacting the After-sales Service, please check the conditions of batteries and cables and replace them, if necessary. Should the instrument still operate improperly, check that the product is operated according to the instructions given in this manual. Should the instrument be returned to the After-sales Service or to a Dealer, transport will be at the Customer's charge. However, shipment will be agreed in advance. A report will always be enclosed to a shipment, stating the reasons for the product's return. Only use original packaging for shipment; any damage due to the use of non-original packaging material will be charged to the Customer.



HT ITALIA SRL

Via della Boaria, 40

48018 – Faenza (RA) – Italy

T +39 0546 621002 | F +39 0546 621144

M ht@ht-instruments.com | www.ht-instruments.it

WHERE
WE ARE



HT INSTRUMENTS SL

C/ Legalitat, 89

08024 Barcelona – Spain

T +34 934 081 777

M sat@htinstruments.es | www.htinstruments.es

HT INSTRUMENTS GmbH

Am Waldfriedhof 1b

D-41352 Korschenbroich – Germany

T +49 (0) 2161 564 581 | F +49 (0) 2161 564 583

M info@ht-instruments.de | www.ht-instruments.de