

# PROFITEST INTRO

Tester per IEC 60364-6

3-349-840-03  
6/1.24



# Table of Contents

	Page		Page
<b>1</b>	<b>Safety Instructions</b> .....	<b>3</b>	<b>12</b>
<b>2</b>	<b>Applications</b> .....	<b>4</b>	<b>12.1</b>
2.1	Intended Use / Use for Intended Purpose .....	4	Measuring Touch Voltage (with reference to nominal residual current) with $\frac{1}{3}$ Nominal Residual Current and Tripping Test with Nominal Residual Current .....
2.2	Use for Other than Intended Purpose .....	4	36
2.3	Liability and Guarantee .....	4	<b>12.2</b>
2.4	Opening the Instrument / Repairs .....	4	Special Tests for Systems and RCDs .....
2.5	Included Features .....	4	37
<b>3</b>	<b>Documentation</b> .....	<b>5</b>	12.2.1
3.1	Firmware/Software Version .....	5	Testing Systems and RCCBs with Rising Residual Current (AC) with Rising Residual Current (AC) for Type AC, A/F, B/B+ and EV, MI RCDs .....
3.2	List of Abbreviations and their Meanings .....	5	37
<b>4</b>	<b>Getting Started</b> .....	<b>6</b>	12.2.2
<b>5</b>	<b>The Instrument</b> .....	<b>6</b>	Testing Systems and RCCBs with Rising Residual Current (AC) for Type B/B+ and EV, MI RCDs .....
5.1	Scope of Delivery .....	6	38
5.2	Optional Accessories .....	6	12.2.3
5.3	Meanings of Symbols on the Instrument .....	6	Testing RCCBs with $5 \times I_{\Delta N}$ .....
5.4	Instrument Overview .....	7	38
5.5	Characteristic Values .....	9	12.2.4
5.6	Technical Data for KS-PROFITEST INTRO (Z503L) (scope of delivery) .....	11	Testing of RCCBs which are Suitable for Pulsating DC Residual Current .....
<b>6</b>	<b>Operating and Display Elements</b> .....	<b>11</b>	<b>12.3</b>
6.1	Display .....	11	Testing of Special RCDs .....
6.2	LED Indications, Mains Connections and Potential Differences	12	12.3.1
<b>7</b>	<b>Operation</b> .....	<b>18</b>	Systems with Type RCD-S (selective) .....
7.1	Power Supply .....	18	39
7.1.1	Installing or Replacing the (Rechargeable) Battery Pack .....	18	12.3.2
7.1.2	(Rechargeable) Battery Test .....	18	PRCDs with Non-Linear Type PRCD-K Elements .....
7.1.3	Charging the Battery Pack (Z502H/Z505U) in the Test Instrument ..	18	40
7.2	Switching the Instrument On/Off .....	19	12.3.3
7.3	Attaching the Test Probe Holders to the Carrying Strap .....	19	SRCD, PRCD-S (SCHUKOMAT, SIDOS or comparable) .....
<b>8</b>	<b>Instrument Settings</b> .....	<b>20</b>	41
<b>9</b>	<b>Database, Saving Data and Generating Reports</b> .....	<b>24</b>	12.3.4
9.1	Creating Distributor Structures, General .....	24	Testing Residual Current Circuit Breakers in TN-S Systems ....
9.2	Transferring Distributor Structures .....	24	42
9.3	Creating a Distributor Structure in the Test Instrument .....	24	<b>13</b>
9.3.1	Creating Structures (example for electrical circuit) .....	25	Testing of Breaking Requirements for Overcurrent Protective Devices, Measurement of Loop Impedance and Determination of Short-Circuit Current ( $Z_{L-PE}$ and $I_{SC}$ functions) .....
9.3.2	Searching for Structure Elements .....	26	43
9.4	Saving Data and Generating Reports .....	27	13.1
9.5	Data Evaluation and Report Generation with ETC Software .....	28	Measurements with Suppression of RCD Tripping .....
9.6	Use of Barcode Scanners and RFID Readers .....	28	44
<b>10</b>	<b>General Notes Concerning Measurements</b> .....	<b>29</b>	13.1.1
10.1	Using Cable Sets and Test Probes .....	29	Measurement with Positive Half-Waves .....
10.2	Connecting the Instrument .....	29	44
10.3	Automatic Settings, Monitoring and Shutdown .....	29	13.2
10.4	Measured Value Display and Memory .....	29	Evaluation of Measured Values .....
10.5	Testing Earthing Contact Sockets for Correct Connection .....	29	45
10.6	Help Function .....	30	13.3
10.7	Setting Parameters or Limit Values using RCD Measurement as an Example .....	31	Settings for Calculating Short-Circuit Current – Parameter $I_{SC}$ .....
10.8	Freely Selectable Parameter Settings or Limit Values .....	32	45
10.9	2-Pole Measurement with Fast or Semiautomatic Polarity Reversal .....	32	<b>14</b>
<b>11</b>	<b>Measuring Voltage and Frequency</b> .....	<b>33</b>	Measuring Supply Impedance ( $Z_{L-N}$ function) .....
11.1	Single-Phase Measurement .....	33	46
11.1.1	Voltage Between L and N ( $U_{L-N}$ ), L and PE ( $U_{L-PE}$ ) and N and PE ( $U_{N-PE}$ ) with Country-Specific Measuring Adapter, e.g. SCHUKO ..	33	<b>15</b>
11.1.2	Voltage Between L – PE, N – PE and L – L with 2-Pole Connection	33	Earthing Resistance Measurement (function $R_E$ ) .....
11.2	3-Phase Measurement (line-to-line voltage) and Phase Sequence .....	34	48
			15.1
			Earthing Resistance, Mains Operation – 2-Pole Measurement with KS-PROFITEST INTRO or Country-Specific Measuring Adapter (Schuko) .....
			49
			<b>16</b>
			Measurement of Insulation Resistance .....
			51
			16.1
			General .....
			51
			16.2
			Special Case: Earth Leakage Resistance (REINS) .....
			53
			<b>17</b>
			Measuring Low-Value Resistance of up to 200 $\Omega$ (protective conductor and equipotential bonding conductor) .....
			54
			17.1
			Measurement with Constant Test Current .....
			55
			<b>18</b>
			Special Functions – EXTRA Switch Position .....
			56
			18.1
			Voltage Drop Measurement (with $Z_{LN}$ ) – $\Delta U$ Function .....
			56
			<b>19</b>
			Maintenance .....
			57
			19.1
			Firmware Version and Calibration Information .....
			57
			19.2
			(Rechargeable) Battery (Pack) Care .....
			57
			19.3
			Fuses .....
			57
			19.4
			Housing .....
			57
			<b>20</b>
			Contact, Support and Service .....
			57
			<b>21</b>
			CE Declaration .....
			57
			<b>22</b>
			Disposal and Environmental Protection .....
			58
			<b>23</b>
			Appendix .....
			59
			23.1
			Tables for the determination of maximum or minimum display values under consideration of maximum measuring uncertainty .....
			59
			23.2
			At which values should/must an RCD actually be tripped? Requirements for Residual Current Devices (RCD) .....
			61
			23.3
			Bibliography .....
			62

# 1 Safety Instructions

Observe this documentation, the operating instructions and in particular all included safety information, in order to protect yourself and others from injury, and to prevent damage to the instrument.

The operating instructions and the condensed operating instructions should be made available to all users.

## General

- Tests/measurements may only be performed by a qualified electrician, or under the supervision and direction of a qualified electrician. The user must be instructed by a qualified electrician concerning performance and evaluation of tests and/or measurements.
- Observe the five safety rules in accordance with DIN VDE 0105-100, Operation of electrical installations – Part 100: General requirements (1. Shut down entirely. 2. Secure against restart. 3. Assure absence of voltage at all poles. 4. Ground and short circuit. 5. Cover neighboring live components, or make them inaccessible.)
- Observe and comply with all safety regulations which are applicable for your work environment.
- Wear suitable and appropriate personal protective equipment (PPE) whenever working with the instrument.
- The functioning of active medical devices (e.g. pacemakers, defibrillators) and passive medical devices may be affected by voltages, currents and electromagnetic fields generated by the instrument and the health of their users may be impaired. Implement corresponding protective measures in consultation with the manufacturer of the medical device and your physician. If any potential risk cannot be ruled out, do not use the instrument.

## Accessories

- Use only the specified accessories (included in the scope of delivery or listed as options) with the instrument.
- Carefully and completely read and adhere to the product documentation for optional accessories. Retain these documents for future reference.

## Handling

- Use the instrument in undamaged condition only.
- Inspect the instrument before use. Pay particular attention to damage, interrupted insulation or kinked cables. Damaged components must be replaced immediately.
- Use the accessories and all cables in undamaged condition only.  
Inspect accessories and all cables before use. Pay particular attention to damage, interrupted insulation or kinked cables.
- If the instrument or its accessories don't function flawlessly, permanently remove the instrument/accessories from operation and secure them against inadvertent use.
- If the instrument or accessories are damaged during use, for example if they're dropped, permanently remove the instrument/accessories from operation and secure them against inadvertent use.
- If there are any signs of interior damage to the instrument or accessories (e.g. loose parts in the housing), permanently remove the instrument/accessories from operation and secure them against inadvertent use.
- The instrument and the accessories may only be used for the tests/measurements described in the documentation for the instrument.
- Route cables in an orderly fashion, for example the mains cable and accessory cables. Loose, disorderly cables result in unnecessary danger of tripping and falling.
- Neither the integrated voltage measuring function nor the mains check may be used to test systems or system components for the absence of voltage.  
Testing for the absence of voltage is only permissible with a suitable voltage tester or voltage measuring system which fulfills the requirements specified in DIN EN 61243.

## Operating Conditions

- Do not use the instrument and its accessories after long periods of storage under unfavorable conditions (e.g. humidity, dust or extreme temperature).
- Do not use the instrument and its accessories after extraordinary stressing due to transport.
- The instrument must not be exposed to direct sunlight.
- Only use the instrument and its accessories within the limits of the specified technical data and conditions (ambient conditions, IP protection code, measuring category etc.).
- Do not use the instrument in potentially explosive atmospheres.

## Rechargeable Batteries / Batteries

- Use batteries in undamaged condition only. Risk of explosion and fire in the case of damaged batteries!  
Inspect the batteries before use. Pay particular attention to leaky and damaged batteries.
- When using (rechargeable) batteries, the respective test/measuring instrument may only be used with inserted and secured battery compartment lid. Otherwise, dangerous voltages may occur at the battery contacts under certain circumstances.
- Do not use the instrument while the internal batteries are being charged.
- Only charge undamaged batteries. Risk of explosion and fire in the case of damaged rechargeable batteries!

## Fuses

- The instrument may only be used as long as the fuses are in flawless condition. Defective fuses must be replaced. Fuses may only be replaced by our repair service department.
- Never bypass the fuses. Never disable the fuses.

## Measurement Cables and Establishing Contact

- Plugging in the measurement cables must not necessitate any undue force.
- Never touch conductive ends (e.g. of test probes).
- Fully unroll all measurement cables before starting a test/measurement. Never perform a test/ measurement with the measurement cable rolled up.
- Avoid short circuits due to incorrectly connected measurement cables.
- Ensure that the test probes make good contact.
- In so far as possible, do not move or remove plugs, test probes, alligator clips or Kelvin probes until testing/measurement has been completed.  
Unwanted sparking may otherwise occur due to test current.

## Data Security

- Always create a backup copy of your measurement data.
- Observe and comply with the respectively applicable national data protection regulations. Use the corresponding functions provided by the test instrument such as access protection, as well as other appropriate measures.

## 2 Applications

Please read this important information!

### 2.1 Intended Use / Use for Intended Purpose

The PROFITEST INTRO (M520T) measuring and test instrument is used to test the effectiveness of protective measures at stationary electrical installations after completion, repair or expansion, and for periodic testing (DGUV regulation 3) in accordance with DIN VDE 0100-600 (IEC 60364-6), ÖVE-EN 1, SEV 1000, NIV/NIN and other country-specific standards, and as defined in the relevant sections of DIN EN 61557 (VDE 0413).

The applications range of the measuring/test instrument covers all alternating and 3-phase current systems with nominal voltages of 230/400 V (300/500 V) and nominal frequencies of 16.7, 50, 60, 200 and 400 Hz. Measuring categories: 300 V CAT IV and 600 V CAT III.

A system structure is set up in the measuring/test instrument and measured values are assigned to the objects and saved. Completed tests and measured values can be archived and documented in a measurement and test report and printed out with the help of ETC PC software (e.g. all values required for a ZVEH acceptance report).

Safety of the operator, as well as that of the measuring/test instrument, is only assured when it's used for its intended purpose.

### 2.2 Use for Other than Intended Purpose

Using the measuring/test instrument for any purposes other than those described in these condensed operating instructions, or in the measuring/test instrument's operating instructions, is contrary to use for intended purpose.

### 2.3 Liability and Guarantee

Gossen Metrawatt GmbH assumes no liability for property damage, personal injury or consequential damage resulting from improper or incorrect use of the product, in particular due to failure to observe the product documentation. Furthermore, all guarantee claims are rendered null and void in such cases.

Nor does Gossen Metrawatt GmbH assume any liability for data loss.

### 2.4 Opening the Instrument / Repairs

In order to ensure flawless, safe operation and to assure that the guarantee isn't rendered null and void, the measuring/test instrument may only be opened by authorized, trained personnel. Even original replacement parts may only be installed by authorized, trained personnel.

Unauthorized modification of the test/measuring instrument is prohibited.

If it can be ascertained that the measuring/test instrument has been opened by unauthorized personnel, no guarantee claims can be honored by the manufacturer with regard to personal safety, measuring accuracy, compliance with applicable safety measures or any consequential damages.

If the guarantee seal is damaged or removed, all guarantee claims are rendered null and void.

## 2.5 Included Features

Testing of Residual Current Devices (RCDs)
$U_B$ measurement without tripping the RCD
Tripping time measurement
Measurement of tripping current $I_F$
Selective, SRCDS, PRCDs, type G/R
AC/DC sensitive RCDs, types B and B+, EV, MI
Testing for N-PE reversal
Measurement of Loop Impedance $Z_{L-PE} / Z_{L-N}$
Fuse table for systems without RCDs
Without tripping the RCD, fuse table
With 15 mA test current <sup>1</sup> , without tripping the RCD
Earthing resistance $R_E$ (mains operation)
Measurement of equipotential bonding $R_{LO}$
Automatic polarity reversal
Insulation resistance $R_{INS}$
Variable or rising test voltage (ramp)
Voltage $U_{L-N} / U_{L-PE} / U_{N-PE} / f$
Special Measurements
Direction
Earth leakage resistance $R_{E(INS)}$
Voltage drop ( $\Delta U$ )
Features
Selectable user interface language
D, GB, I, F, E, P, NL, S, N, FIN, CZ, PL
Memory (database for up to 50,000 objects)
RS 232 port for RFID/barcode scanner
USB port for data transmission
ETC user PC software
Measuring category: CAT III 600 V / CAT IV 300 V
Factory calibration certificate

<sup>1</sup> The so-called live measurement is only advisable if there is no bias current within the system. Only suitable for motor protection switches with small nominal current values.

## 3 Documentation

### 3.1 Firmware/Software Version

These operating instructions describe a test instrument with software version 1.20.10.

### 3.2 List of Abbreviations and their Meanings

RCCBs (residual current circuit breakers / RCDs):

$I_{\Delta}$  Tripping current

$I_{\Delta N}$  Nominal residual current

$I_{F\blacktriangleleft}$  Rising test current (residual current)

PRCD Portable residual current device

PRCD-S:

with protective conductor detection and monitoring

PRCD-K:

with undervoltage trigger and protective conductor monitoring

**RCD-S** Selective RCCB

$R_E$  Calculated earthing or earth electrode loop resistance

SRCD Socket residual current device (permanently installed)

$t_a$  Time to trip / breaking time

$U_{I\Delta}$  Touch voltage at moment of tripping

$U_{I\Delta N}$  Touch voltage relative to nominal residual current  $I_{\Delta N}$

$U_L$  Touch voltage limit value

Overcurrent protective devices:

$I_{SC}$  Calculated short-circuit current (at nominal voltage)

$Z_{L-N}$  Line impedance

$Z_{L-PE}$  Loop impedance

Earthing:

$R_B$  Operational earth resistance

$R_E$  Measured earthing resistance

$R_{E\text{Loop}}$  Earth electrode loop resistance

Low-value resistance at

protective, earthing and bonding conductors:

$R_{LO+}$  Equipotential bonding conductor resistance (+ pole to PE)

$R_{LO-}$  Equipotential bonding conductor resistance (– pole to PE)

Insulation:

$R_{E(INS)}$  Earth leakage resistance (DIN 51953)

$R_{INS}$  Insulation resistance

Current:

$I_A$  Breaking current

$I_M$  Measuring current

$I_N$  Nominal current

$I_P$  Test current

Voltage:

$f$  Line voltage frequency

$f_N$  Nominal voltage rated frequency

$\Delta U$  Voltage drop as %

$U$  Voltage measured at the test probes during and after insulation measurement  $R_{INS}$

$U_{Batt}$  (Rechargeable) battery voltage

$U_E$  Earth electrode voltage

$U_{INS}$  When measuring  $R_{INS}$ : test voltage for ramp function: tripping or breakdown voltage

$U_{L-L}$  Voltage between two phase conductors

$U_{L-N}$  Voltage between L and N

$U_{L-PE}$  Voltage between L and PE

$U_N$  Nominal line voltage

$U_{3\sim}$  Highest measured voltage during determination of phase sequence

$U_Y$  Conductor voltage to earth

## 4 Getting Started

- 1 Read and adhere to the product documentation. In particular, observe all safety information in the documentation, on the instrument and on the packaging.  
See:
  - Section 1, “Safety Instructions”, beginning on page 3
  - Section 3, “Documentation”, beginning on page 5
  - Section 3, “Documentation”, on page 6
- 2 Familiarize yourself with the test instrument. See:
  - Section 5, “The Instrument”, beginning on page 67
  - Section 6, “Operating and Display Elements”, beginning on page 11
  - Section 7, “Operation”, beginning on page 18
- 3 Enter the basic settings.  
See Section 8, “Instrument Settings”, beginning on page 20.
- 4 Optional but recommended: Create a database in the test instrument. See Section 9, “Database, Saving Data and Generating Reports”, beginning on page 24.
- 5 Read the basic information provided in Section 10, “General Notes Concerning Measurements”, beginning on page 29.
- 6 Perform measurements. See:
  - Section 11, “Measuring Voltage and Frequency”, beginning on page 33
  - Section 12, “Testing RCDs”, beginning on page 35
  - Section 13, “Testing of Breaking Requirements for Overcurrent Protective Devices, Measurement of Loop Impedance and Determination of Short-Circuit Current ( $Z_{L-PE}$  and  $I_{SC}$  functions)”, beginning on page 43
  - Section 14, “Measuring Supply Impedance ( $Z_{L-N}$  function)”, beginning on page 46
  - Section 15, “Earthing Resistance Measurement (function  $R_E$ )”, beginning on page 48
  - Section 16, “Measurement of Insulation Resistance”, beginning on page 51
  - Section 17, “Measuring Low-Value Resistance of up to 200  $\Omega$  (protective conductor and equipotential bonding conductor)”, beginning on page 54
  - Section 18, “Special Functions – EXTRA Switch Position”, beginning on page 56
- 7 Optional but recommended: We advise you to regularly transfer your stored data to a PC. We recommend the use of ETC PC software for data processing. See Section 9.4, “Saving Data and Generating Reports”, beginning on page 27.

## 5 The Instrument

### 5.1 Scope of Delivery

- 1 Test instrument
- 1 Shoulder strap
- 1 Battery pack (8 batteries + holder)
- 1 KS-PROFITEST INTRO (Z503L)
- 1 Factory calibration certificate
- 1 Condensed operating instructions
  - Comprehensive operating instructions available for download at [www.gossenmetrawatt.com](http://www.gossenmetrawatt.com)

### 5.2 Optional Accessories

A broad range of optional accessories is available for the PROFITEST INTRO, which simplifies work with the instrument. Optional accessories are required for some measurements, which is indicated in these operating instructions.

Please refer to the data sheet for complete information regarding optional accessories.

### 5.3 Meanings of Symbols on the Instrument



Warning concerning a point of danger (attention, observe documentation!)



Protection category II device



Charging socket for extra-low direct voltage (Z502R charger)



#### Attention!

Only battery packs listed as accessories (Z502H, Z505U) may be charged in the instrument!



The instrument may not be disposed of with household trash. See Section 22, “Disposal and Environmental Protection”, beginning on page 58.



EU conformity marking



If the guarantee seal is damaged or removed, all guarantee claims are rendered null and void.

## 5.4 Instrument Overview

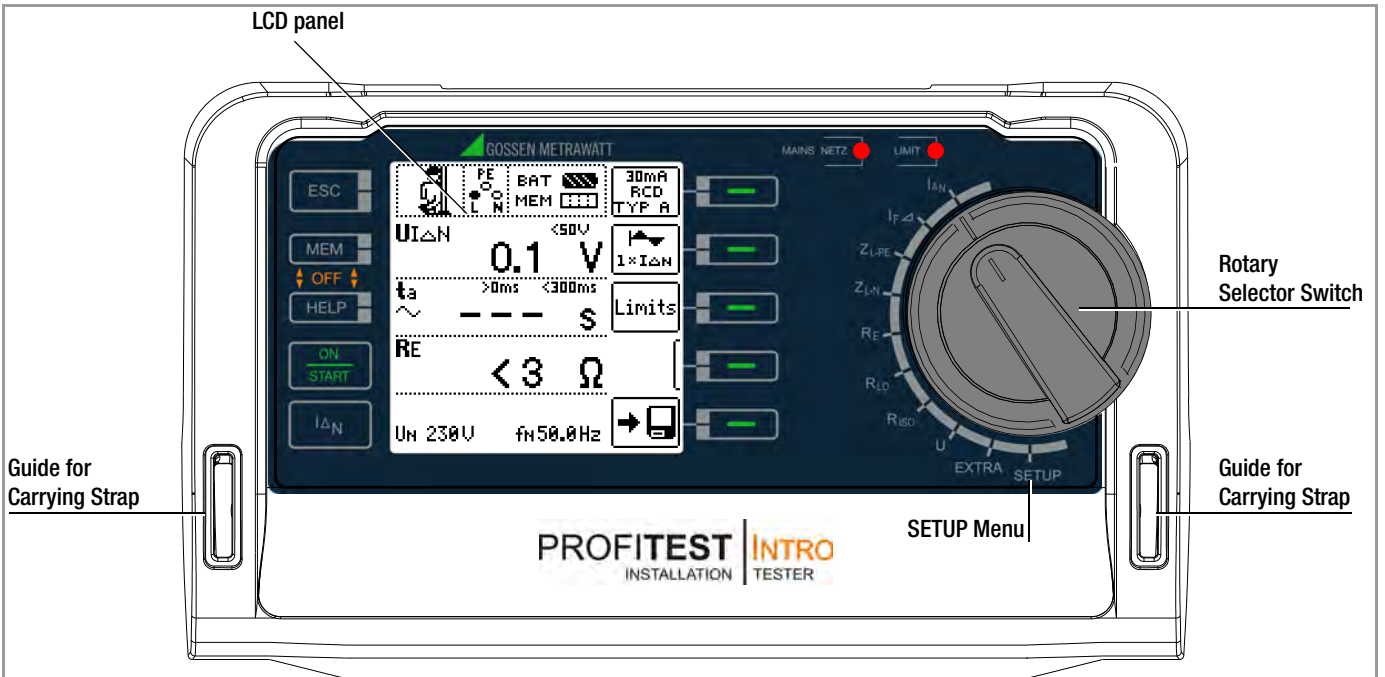

### Control Panel

#### Fixed Function Keys

- ESC:** Return to submenu / activate instrument from standby state
- MEM:** Key for memory functions
- HELP:** Access context sensitive help
- START:** Switch on / start measurement
- I $\Delta$ N:** Triggering key / compensation (OFFSET)

#### Softkeys

- Parameter selection
- Limit value specification
- Entry functions
- Memory functions

**MAINS/NETZ LED**  
→ See below

**Limit LED**  
→ See below

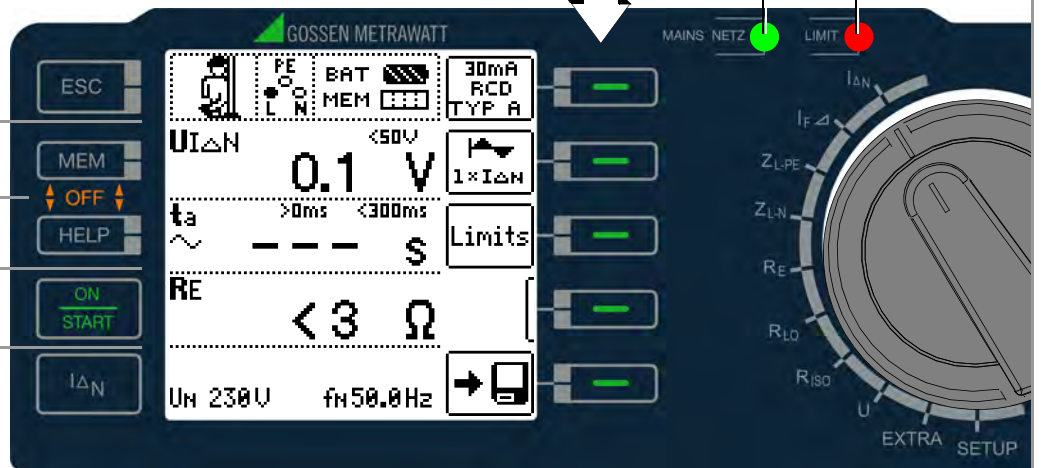

#### LED Indications (see also section 6.2)

LED Case A	LED Case B	LCD Case A	LCD Case B	Function – Cause
Mains Green	Mains Blinks green			A Lights up green: Correct connection, measurement enabled B Blinks green: Neutral conductor not connected, measurement enabled
Mains Orange	Mains Blinks red			A Lights up orange: 2 different phases active (no neutral conductor at mains), measurement enabled B Blinks red: I $\Delta$ N, I $\Delta$ I, ZL-PE, ZL-N, RE: no line voltage or PE interrupted C Lights up red: RINS and RLO: Interference voltage detected, measurement disabled
LIMIT Red				– UI $\Delta$ , UI $\Delta$ N: Touch vltg. > 25 V or > 50 V, measurement disabled: U.PE > UL! appears – I $\Delta$ N: During the tripping test with I $\Delta$ N, the RCD is not tripped within 400 ms (1000 ms for selective RCCBs of type RCD S). – I $\Delta$ I: With rising residual current, the RCD is not tripped before reaching I $\Delta$ N. – After safety shutdown – RLO: The permissible (selected) limit value has been exceeded. – RINS, RE(INS): The permissible (selected) limit value has been fallen short of.

## Batteries, Fuses

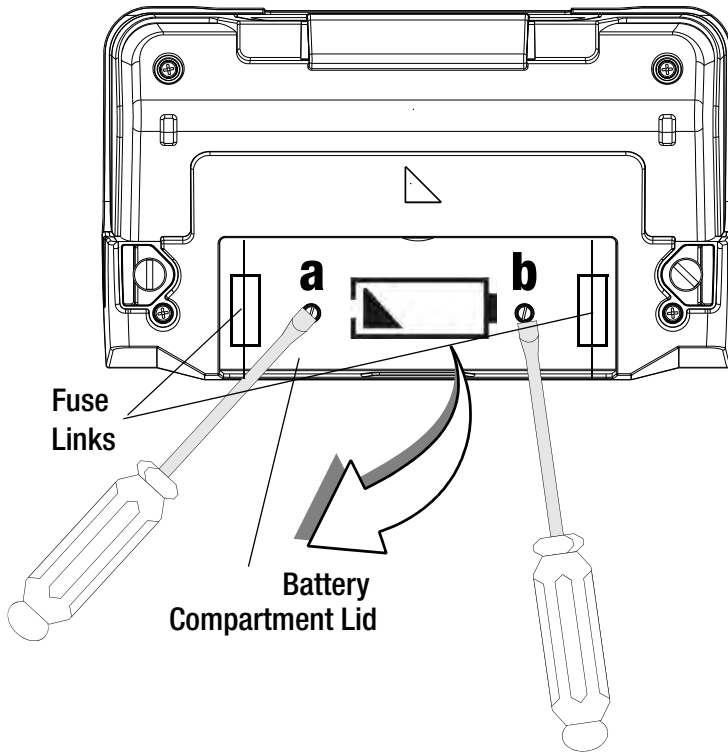

## Inserting the Battery Holder (side view)

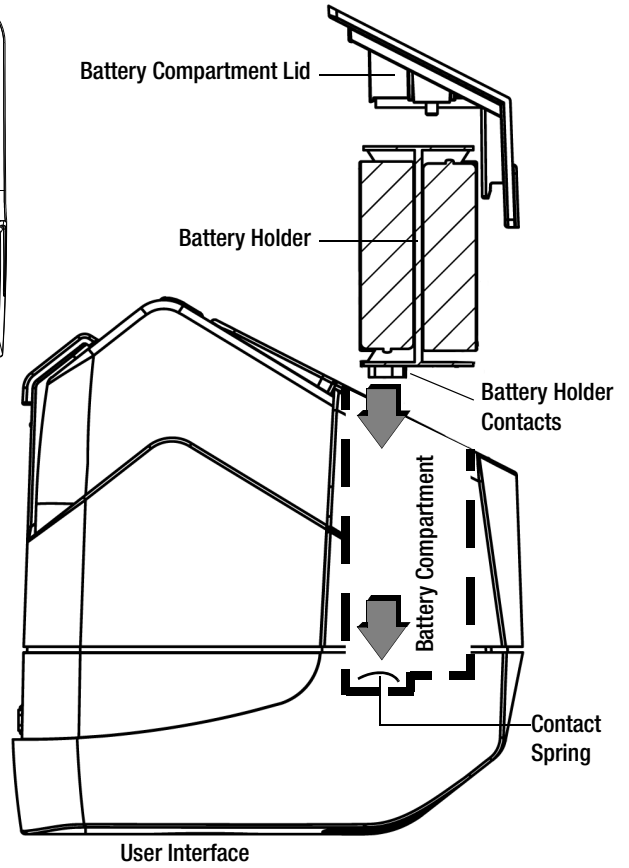

## Measuring Connections

### Test Probe with Remote Control, Option Z550A

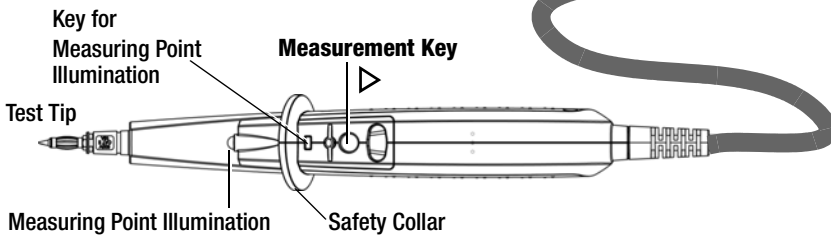

### Assignment of Keys to Device or Remote Control

Measuring Function	At Device	Via Remote Control	At Device	Via Remote Control
	Start Measurement		Tripping Test	
I $\Delta$ N IF $\Delta$				
Meas. Function	Start Measurement		OFFSET	
ZL-PE, ZL-N RE RLO, $\Delta$ U				
RISO				

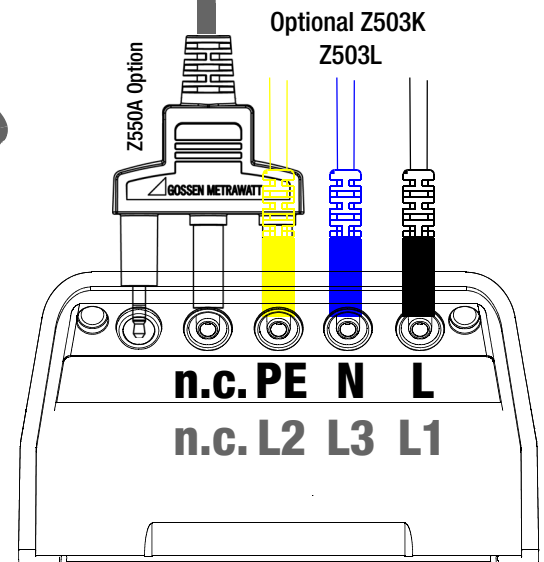

## Charger Socket, Interfaces

These connections are located under a protective rubber flap.

### Socket for Z502R Charger

#### Attention!

Ensure that no batteries are inserted before connecting the charger. The test instrument must remain off during the charging process.





## 5.5 Characteristic Values

Function	Measured Quantity	Display Range	Resolution	Input Impedance / Test Current	Measuring Range	Nominal Values	Measuring Uncertainty	Intrinsic Uncertainty	Connections			
									PRO-Schuko adapter <sup>1</sup>	KS-PROFITEST INTRO	2-pin	3-pin
U I <sub>ΔN</sub> I <sub>F</sub>	U <sub>L-PE</sub> U <sub>N-PE</sub>	0.0 ... 99.9 V 100 ... 600 V	0.1 V 1 V	5 MΩ	0.3 ... 600 V <sup>1</sup>	U <sub>N</sub> = 120 V / 230 V / 400 V / 500 V	±(2% rdg. + 5 d) ±(2% rdg.+ 1 d)	±(1% rdg. + 5 d) ±(1% rdg.+ 1 d)	•	•	•	
	f	15.0 ... 99.9 Hz 100 ... 999 Hz	0.1 Hz 1 Hz		DC 15.4 Hz ... 420 Hz		±(0.2% rdg.+ 1 d)	±(0.1% rdg.+ 1 d)				
	U <sub>3~</sub>	0.0 ... 99.9 V 100 ... 600 V	0.1 V 1 V		0.32 ... 600 V	f <sub>N</sub> = 16.7 Hz / 50 Hz / 60 Hz / 200 Hz / 400 Hz	±(3% rdg. + 5 d) ±(3% rdg.+ 1 d)	±(2% rdg. + 5 d) ±(2% rdg.+ 1 d)			•	
	U <sub>L-N</sub>	0.0 ... 99.9 V 100 ... 600 V	0.1 V 1 V		1.0 ... 600 V <sup>1</sup>		±(3% rdg. + 5 d) ±(3% rdg.+ 1 d)	±(2% rdg. + 5 d) ±(2% rdg.+ 1 d)	•		•	
	U <sub>IΔN</sub>	0.0 ... 70.0 V	0.1 V	0.3 × I <sub>ΔN</sub>	5 ... 70 V	U <sub>N</sub> = 120 V 230 V 400 V <sup>2</sup>  f <sub>N</sub> = 50 Hz / 60 Hz  U <sub>L</sub> = 25 V / 50 V  I <sub>ΔN</sub> = 6 mA 10 mA 30 mA 100 mA 300 mA 500 mA <sup>2</sup>	+13% rdg. + 1 d	+1% rdg. - 1 d ... +9% rdg. + 1 d				
	R <sub>E</sub>	10 Ω ... 999 Ω 1.00 kΩ ... 6.51 kΩ	1 Ω 0.01 kΩ	I <sub>ΔN</sub> = 10 mA × 1.05	Calculated value based on R <sub>E</sub> = U <sub>IΔN</sub> / I <sub>ΔN</sub>		U <sub>N</sub> = 120 V / 230 V / 400 V <sup>2</sup> f <sub>N</sub> = 50 Hz / 60 Hz	±(7% rdg.+ 2 d)	±(3.5% rdg.+ 2 d)	•	•	
		3 Ω ... 999 Ω 1 kΩ ... 2.17 kΩ	1 Ω 0.01 kΩ	I <sub>ΔN</sub> = 30 mA × 1.05								
		1 Ω ... 651 Ω	1 Ω	I <sub>ΔN</sub> = 100 mA × 1.05								
		0.3 Ω ... 99.9 Ω 100 Ω ... 217 Ω	0.1 Ω 1 Ω	I <sub>ΔN</sub> = 300 mA × 1,05								
	I <sub>F</sub> (I <sub>ΔN</sub> = 6 mA)	1.8 ... 7.8 mA	0.1 mA	I <sub>ΔN</sub> = 500 mA × 1,05	1.8 ... 7.8 mA		U <sub>L</sub> = 25 V / 50 V	±(7% rdg.+ 2 d)	±(3.5% rdg.+ 2 d)	•	•	
		I <sub>F</sub> (I <sub>ΔN</sub> = 10 mA)	3.0 ... 13.0 mA	0.1 mA	3.0 ... 13.0 mA							
	I <sub>F</sub> (I <sub>ΔN</sub> = 30 mA)	9.0 ... 39.0 mA	0.1 mA	9.0 ... 39.0 mA	9.0 ... 39.0 mA							
	I <sub>F</sub> (I <sub>ΔN</sub> = 100 mA)	30 ... 130 mA	1 mA	30 ... 130 mA	30 ... 130 mA							
	I <sub>F</sub> (I <sub>ΔN</sub> = 300 mA)	90 ... 390 mA	1 mA	90 ... 390 mA	90 ... 390 mA							
	I <sub>F</sub> (I <sub>ΔN</sub> = 500 mA)	150 ... 650 mA	1 mA	150 ... 650 mA	150 ... 650 mA							
	U <sub>IΔ</sub> / U <sub>L</sub> = 25 V	0.0 ... 25.0 V	0.1 V	Same as I <sub>Δ</sub>	0 ... 25.0 V		U <sub>N</sub> = 120 V / 230 V / 400 V <sup>2</sup> f <sub>N</sub> = 50 Hz / 60 Hz	+10% rdg. + 1 d	+1% rdg. - 1 d ... +9% rdg.+ 1 d	•	•	
	U <sub>IΔ</sub> / U <sub>L</sub> = 50 V	0.0 ... 50.0 V			0 ... 50.0 V							
	t <sub>A</sub> (I <sub>ΔN</sub> × 1)	0 ... 999 ms	1 ms	6 ... 500 mA	0 ... 999 ms							
t <sub>A</sub> (I <sub>ΔN</sub> × 2)	0 ... 999 ms	1 ms	2 × 6 mA ... 2 × 500 mA	0 ... 999 ms								
t <sub>A</sub> (I <sub>ΔN</sub> × 5)	0 ... 40 ms	1 ms	5 ... 6 mA ... 5 × 300 mA	0 ... 40 ms								
Z <sub>L-PE</sub> Z <sub>L-N</sub>	Z <sub>L-PE</sub> (AC) Z <sub>L-N</sub>	0 mΩ ... 999 mΩ 1.00 Ω ... 9.99 Ω	1 mΩ 0.01 Ω 0.1 Ω	1.3 A <sub>AC</sub> ... 3.7 A <sub>AC</sub> 0.5 A <sub>DC</sub> / 1.25 A <sub>DC</sub>	300 mΩ ... 999 mΩ 1.00 Ω ... 9.99 Ω	U <sub>N</sub> = 120 V / 230 V / 400 V / 500 V <sup>1</sup> f <sub>N</sub> = 16.7 Hz / 50 Hz / 60 Hz	±(10% rdg.+ 30 d) ±(8% rdg.+ 3 d)	±(5% rdg.+30 d) ±(3% rdg.+ 3 d)	•	•	Z <sub>L-PE</sub>	
	Z <sub>L-PE</sub> (AC + DC)	0 mΩ ... 999 mΩ 1.00 Ω ... 9.99 Ω 10.0 Ω ... 29.9 Ω			500 mΩ ... 999 mΩ 1.00 Ω ... 9.99 Ω		U <sub>N</sub> = 120 V / 230 V f <sub>N</sub> = 50 Hz / 60 Hz	±(18% rdg.+30 d) ±(10% rdg.+ 3 d)				±(6% rdg.+ 50 d) ±(4% rdg.+ 3 d)
	I <sub>SC</sub> (Z <sub>L-PE</sub> )	0.0 ... 9.9 A 10 ... 999 A	0.1 A 1 A		120 V (108 ... 132 V) 230 V (196 ... 253 V) 400 V (340 ... 440 V) 500 V (450 ... 550 V)	Value calculated from Z <sub>L-PE</sub>						
	Z <sub>L-PE</sub> (AC + DC)	0.0 ... 9.9 A 10 ... 999 A	0.1 A 1 A		10 A 100 A	Value calculated from Z <sub>L-PE</sub>						
	Z <sub>L-PE</sub> (15 mA)	0.5 Ω ... 9.99 Ω 10.0 Ω ... 99.9 Ω 100 Ω ... 999 Ω	0.01 Ω 0.1 Ω 1 Ω		10.0 Ω ... 99.9 Ω 100 Ω ... 999 Ω	U <sub>N</sub> = 120 V / 230 V f <sub>N</sub> = 16.7 Hz / 50 Hz / 60 Hz	±(10% rdg.+ 10 d) ±(8% rdg.+ 2 d)	±(2% rdg.+ 2 d) ±(1% rdg.+ 1 d)				
	I <sub>SC</sub> (15 mA)	100 ... 999 mA 0.00 ... 9.99 A 10.0 ... 99.9 A	1 mA 0.01 A 0.1 A		15 mA <sub>AC</sub>	Calculated value depends on U <sub>N</sub> and Z <sub>L-PE</sub> : I <sub>SC</sub> = U <sub>N</sub> / Z <sub>L-PE</sub> (15 mA)						
R <sub>E</sub>	R <sub>E</sub> (AC)	0 mΩ ... 999 mΩ 1.00 Ω ... 9.99 Ω 10.0 Ω ... 99.9 Ω 100 Ω ... 999 Ω 1 kΩ ... 9.99 kΩ	1 mΩ 0.01 Ω 0.1 Ω 1 Ω 0.01 kΩ	1.3 A <sub>AC</sub> ... 3.7 A <sub>AC</sub> 1.3 A <sub>AC</sub> ... 3.7 A <sub>AC</sub> 400 mA <sub>AC</sub> 40 mA <sub>AC</sub> 4 mA <sub>AC</sub>	300 mΩ ... 999 mΩ 1.00 Ω ... 9.99 Ω 10.0 Ω ... 99.9 Ω 100 Ω ... 999 Ω 1.00 kΩ ... 9.99 kΩ	U <sub>N</sub> = 120 V / 230 V U <sub>N</sub> = 400 V <sup>1</sup> f <sub>N</sub> = 50 Hz / 60 Hz	±(10% rdg.+ 30 d) ±(5% rdg.+ 3 d) ±(10% rdg.+ 3 d) ±(10% rdg.+ 3 d) ±(10% rdg.+ 3 d)	±(5% rdg.+ 30 d) ±(3% rdg.+ 3 d) ±(3% rdg.+ 3 d) ±(3% rdg.+ 3 d) ±(3% rdg.+ 3 d)	•	•		
	R <sub>E</sub> DC+	0 Ω ... 999 mΩ 1.00 Ω ... 9.99 Ω 10.0 Ω ... 29.9 Ω	1 mΩ 0.01 Ω 0.1 Ω	1.3 A <sub>AC</sub> ... 3.7 A <sub>AC</sub> 0.5 A <sub>DC</sub> / 1.25 A <sub>DC</sub>	500 mΩ ... 999 mΩ 1.00 Ω ... 9.99 Ω	U <sub>N</sub> = 120 V / 230 V f <sub>N</sub> = 50 Hz / 60 Hz	±(18% rdg.+30d) ±(10% rdg.+ 3 d)	±(6% rdg.+ 50 d) ±(4% rdg.+ 3 d)				
	U <sub>F</sub>	0 ... 253 V	1 V	—	Calculated value							
Ub	Ub	Limit LED on		Reb = 100 kΩ	0 ... 440 V	U <sub>N</sub> = 120 V / 230 V / 400 V f <sub>N</sub> = 50 Hz / 60 Hz	45 V ±15 V	45 V ±5 V	Finger contact			
R <sub>INS</sub>	R <sub>INS</sub> , R <sub>E INS</sub>	1 kΩ ... 999 kΩ 1.00 MΩ ... 9.99 MΩ 10.0 MΩ ... 49.9 MΩ	1 kΩ 10 kΩ 100 kΩ	I <sub>SC</sub> = 1.5 mA	50 kΩ ... 300 MΩ	U <sub>N</sub> = 50 V I <sub>N</sub> = 1 mA	KΩ range ±(6% rdg.+10 d)	kΩ range ±(3% rdg.+10 d)	•	•		
		1 kΩ ... 999 kΩ 1.00 MΩ ... 9.99 MΩ 10.0 MΩ ... 99.9 MΩ	1 kΩ 10 kΩ 100 kΩ			U <sub>N</sub> = 100 V I <sub>N</sub> = 1 mA						
		1 kΩ ... 999 kΩ 1.00 MΩ ... 9.99 MΩ 10.0 MΩ ... 99.9 MΩ 100 MΩ ... 200 MΩ	1 kΩ 10 kΩ 100 kΩ 1 MΩ			U <sub>N</sub> = 250 V I <sub>N</sub> = 1 mA						
		1 kΩ ... 999 kΩ 1.00 MΩ ... 9.99 MΩ 10.0 MΩ ... 99.9 MΩ 100 MΩ ... 500 MΩ	1 kΩ 10 kΩ 100 kΩ 1 MΩ			U <sub>N</sub> = 500 V U <sub>N</sub> = 1000 V I <sub>N</sub> = 1 mA						
	U	10 V <sub>DC</sub> ... 999 V <sub>DC</sub> 1.00 ... 1.19 kV	1 V 10 V		10 ... 1.19 kV		±(3% rdg.+ 1 d)	±(1.5% rdg. + 1 d)				
R <sub>LO</sub>	R <sub>LO</sub>	0.01 Ω ... 9.99 Ω 10.0 Ω ... 99.9 Ω 100 Ω ... 99 Ω	10 mΩ 100 mΩ 1 Ω	I <sub>m</sub> ≥ 200 mA I <sub>m</sub> < 200 mA	0.20 Ω ... 4.00 Ω 4.01 Ω ... 99.9 Ω	U <sub>0</sub> = 4.5 V	±(5% rdg.+ 2 d)	±(2% rdg.+ 2 d)	•			

<sup>1</sup> U > 230 V with KS-PROFITEST INTRO only

<sup>2</sup> 1 × I<sub>ΔN</sub> > 300 mA and 2 × I<sub>ΔN</sub> > 300 mA and 5 × I<sub>ΔN</sub> > 500 mA and I<sub>F</sub> > 300 mA only up to U<sub>N</sub> ≤ 230 V!  
5 × I<sub>ΔN</sub> > 300 mA only where U<sub>N</sub> = 230 V!

Key d = digit(s), rdg. = reading (measured value)

## Reference Conditions

Line voltage	230 V ± 0.1%
Line frequency	50 Hz ± 0.1%
Measured qty. frequency	45 Hz ... 65 Hz
Measured qty. waveform	Sine (deviation between effective and rectified value ≤ 0.1%)
Supply impedance angle	cos φ = 1
Supply voltage	12 V ± 0.5 V
Ambient temperature	+22 °C ± 3 K
Relative humidity	45% ± 10%

## Nominal Ranges of Use

Voltage $U_N$	120 V	(108 ... 132 V)
	230 V	(196 ... 253 V)
	400 V	(340 ... 440 V)
Frequency $f_N$	16.7 Hz	(15.4 ... 18 Hz)
	50 Hz	(49.5 ... 50.5 Hz)
	60 Hz	(59.4 ... 60.6 Hz)
	200 Hz	(190 ... 210 Hz)
	400 Hz	(380 ... 420 Hz)
Overall voltage range $U_Y$	65 ... 550 V	
Overall frequency range	15.4 ... 420 Hz	
Line voltage	Sinusoidal	
Temperature range	0 °C ... + 40 °C	
Supply voltage	8 ... 12 V	
Supply impedance angle	Corresponds to cos φ = 1 ... 0.95	

## Power Supply

Batteries, rechargeable NiMH batteries	8 each AA 1.5 V We recommend using an optionally available battery pack (Z502H 2000 mAh or Z505U 2620 mAh)
--	---

Number of measurements (standard setup with illumination)	
– For $R_{INS}$	1 measurement – 25 s pause: Approx. 1060 measurements with Z502H battery pack Approx. 1450 measurements with Z505U battery pack
– For $R_{LO}$	Auto polarity reversal / 1 Ω (1 measuring cycle) – 25 s pause: Approx. 1180 measurements with Z502H battery pack Approx. 1600 measurements with Z505U battery pack
Battery test	Symbolic display of battery voltage <b>BAT</b> 
Power management	Display illumination can be switched off. The test instrument is switched off automatically after the last key operation. The user can select the desired on-time.
Safety shutdown	If supply voltage is too low ( $U < 8.0$ V), the instrument is switched off, or cannot be switched on.
Recharging socket	Inserted rechargeable battery packs* can be recharged directly by connecting the Z502R charger to the recharging socket.
Charging time	Battery pack (optionally available, listed as accessory) with Z502R charger: approx. 2 hours**

\* Only available as an option, battery packs listed as accessories (Z505U or Z502H)

\*\* Maximum charging time with fully depleted batteries.

A timer in the charger limits charging time to no more than 4 hours.

## Overload Capacity

$U_{L-PE}, U_{L-N}$	600 V continuous
RCD, $R_E$	440 V continuous
$Z_{L-PE}, Z_{L-N}$	550 V (Limits the number of measurements and pause duration. If overload occurs, the instrument is switched off by means of a thermostatic switch.)
$R_{LO}$	Electronic protection prevents switching on if interference voltage is present.
Protection with 2 fine-wire fuses	FF 3.15 A 10 s, Fuses blow at > 5 A

## Electrical Safety

Protection class	II per IEC 61010-1 / EN 61010-1 / VDE 0411-1
Nominal voltage	230/400 V (300/500 V)
Test voltage	3.7 kV, 50 Hz
Measuring category	CAT III 600 V or CAT IV 300 V
Pollution degree	2
Fuses	
L and N terminals	1 G fuse-link ea. FF 3.15 A, 600 V 6.3 mm × 32 mm

## Electromagnetic Compatibility (EMC)

Product standard EN 61326-1

Interference emission		Class
EN 55022		A
Interference immunity	Test value	Feature
EN 61000-4-2	Contact/atmos. – 4 kV/8 kV	
EN 61000-4-3	3 V/m	

## Ambient Conditions

Accuracy	0 ... + 40 °C
Operation	–5 ... + 50 °C
Storage	–20 ... + 60 °C (without batteries)
Relative humidity	Max. 75%, (max. 85% during storage/transport) no condensation allowed
Elevation	Max. 2000 m
Calibration interval	1 year (recommended)

## Mechanical Design

Display	Multiple display with dot matrix 128 × 128 pixels, backlit (transflective) Dimensions: 65 × 65 mm
Dimensions	W × L × H = 225 × 130 × 140 mm
Weight	Approx. 1.5 kg with batteries
Protection	Housing: IP 52 Measurement cables and connectors: IP40 per EN 60529

## Data Interfaces

Type	USB (2.0, type B socket) for PC connection
Type	RS 232 for connecting barcode or RFID scanner

## 5.6 Technical Data for KS-PROFITEST INTRO (Z503L) (scope of delivery)

Measurement cables (black, blue, yellow-green) with test probe and safety caps, as well as alligator clips for 1000 V CAT III

### Electrical Safety, Measurement Cables

Maximum rated voltage	300 V	600 V	1000 V
Measuring category	CAT IV	CAT III	CAT II
Maximum rated current	1 A	1 A	16 A
With safety cap attached	•	•	—
Without safety cap	—	—	•

### Ambient Conditions (EN 61010-031)

Temperature	-20 °C ... + 50 °C
Relative humidity	Max. 80%
Pollution degree	2

## 6 Operating and Display Elements

### 6.1 Display

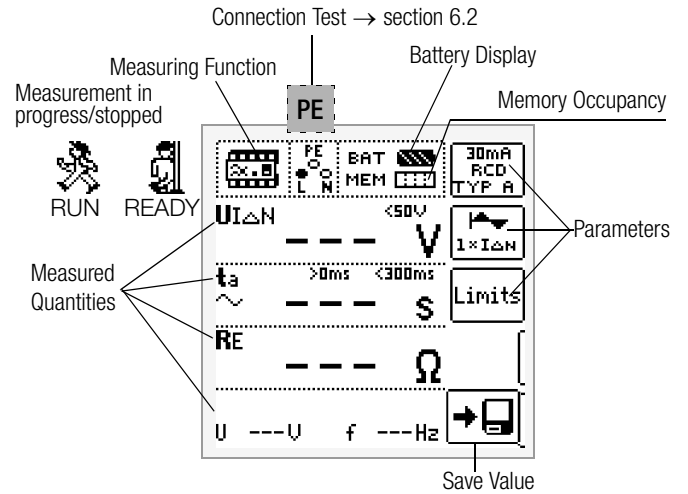

#### Battery Display

- BAT** Battery full
- BAT** Battery weak
- BAT** Battery OK
- BAT** Battery (almost) dead U < 8 V







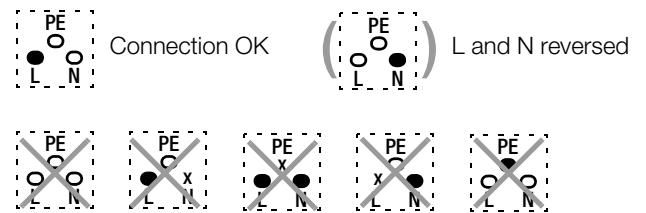

#### Memory Occupancy Display

- MEM** Memory full > transfer data to PC
- MEM** Memory half full









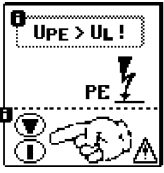

#### Connection Test – Mains Connection Test (→ section 6.2)



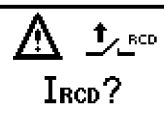
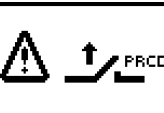

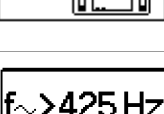



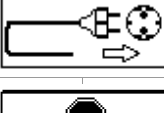

## 6.2 LED Indications, Mains Connections and Potential Differences

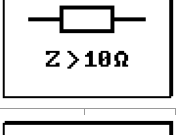
	Status	Error No.	Position of the Function Switch	Function/Meaning
<b>LED Signals</b>				
<b>MAINS/NETZ</b>	Lights up green	Ic1 (Ic = line control)	$I_{\Delta N} / I_F \triangleleft$ $Z_{L-N} / Z_{L-PE} / R_E$ $\Delta U$ , int. ramp, EXTRA	Correct connection, measurement enabled
<b>MAINS/NETZ</b>	Blinks green	Ic2	$I_{\Delta N} / I_F \triangleleft$ $Z_{L-N} / Z_{L-PE} / R_E$ $\Delta U$ , int. ramp	N conductor not connected, measurement enabled
<b>MAINS/NETZ</b>	Lights up orange	Ic3	$I_{\Delta N} / I_F \triangleleft$ $Z_{L-N} / Z_{L-PE} / R_E$	Line voltage of 65 V to 253 V to PE, 2 different phases active (no neutral conductor at mains), measurement enabled
<b>MAINS/NETZ</b>	Blinks red	Ic4	$I_{\Delta N} / I_F \triangleleft$ $Z_{L-N} / Z_{L-PE} / R_E$ $\Delta U$ , int. ramp	1) No line voltage or 2) PE interrupted
<b>MAINS/NETZ</b>	Lights up red	Ic5	RINS / RLO	Interference voltage detected, measurement disabled
<b>MAINS/NETZ</b>	Blinks yellow	Ic6	$I_{\Delta N} / I_F \triangleleft$ $Z_{L-N} / Z_{L-PE} / R_E$	L and N are connected to the phase conductors.
LIMIT	Lights up red	Ic7	$I_{\Delta N}$	– Touch voltage $U_{I\Delta N}$ and $U_{I\Delta}$ > 25 V respectively > 50 V – After safety shutdown
LIMIT	Lights up red	Ic8	$I_F \triangleleft$ int. ramp	– With rising residual current, the RCD is not tripped before reaching $I_N$ . – After safety shutdown
LIMIT	Lights up red	Ic9	RINS / RLO	– Limit value exceeded or fallen short of
<b>Mains Connection Test — Single-Phase System — LCD Connection Pictographs</b>				
	Is displayed	Ic10	All except for U	No connection detected
	Is displayed	Ic11	All except for U	Connection OK
	Is displayed	Ic12	All except for U	L and N reversed, neutral conductor charged with phase voltage
	Is displayed	Ic13	All except U and RE	No mains connection
			RE	Standard display without connection messages
	Is displayed	Ic14	All except for U	Neutral conductor interrupted
	Is displayed	Ic15	All except for U	Protective conductor PE interrupted, neutral conductor N and/or phase conductor L charged with phase voltage
	Is displayed	Ic16	All except for U	Phase conductor L interrupted, neutral conductor N charged with phase voltage
	Is displayed	Ic17	All except for U	Phase conductor L and protective conductor PE reversed
	Is displayed	Ic19	All except for U	L and N are connected to the phase conductors.

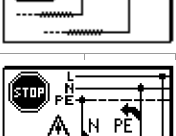
	Status	Error No.	Position of the Function Switch	Function/Meaning
<b>Mains Connection Test — 3-Phase System — LCD Connection Pictographs</b>				
	Is displayed	lc20	U (3-phase measurement)	Clockwise rotation
	Is displayed	lc21	U (3-phase measurement)	Counterclockwise rotation
	Is displayed	lc22	U (3-phase measurement)	Short between L1 and L2
	Is displayed	lc23	U (3-phase measurement)	Short between L1 and L3
	Is displayed	lc24	U (3-phase measurement)	Short between L2 and L3
	Is displayed	lc25	U (3-phase measurement)	Conductor L1 missing
	Is displayed	lc26	U (3-phase measurement)	Conductor L2 missing
	Is displayed	lc27	U (3-phase measurement)	Conductor L3 missing
	Is displayed	lc28	U (3-phase measurement)	Conductor L1 to N
	Is displayed	lc29	U (3-phase measurement)	Conductor L2 to N
	Is displayed	lc30	U (3-phase measurement)	Conductor L3 to N
<b>Battery Test</b>				
	Is displayed		All	<b>Safety Shutdown</b> (Rechargeable) battery voltage is less than or equal to 8.0 V. Reliable measurement is no longer possible. Storage of measured values to memory is disabled. Remedy: Rechargeable NiMH batteries must be recharged, or batteries must be replaced towards the end of their service life.
<b>PE Test</b>				
<b>LCD</b>	<b>LED</b>			
	<b>LIMIT</b> Lights up red		U (single-phase measurement)	Potential difference $\geq 45$ V to PE (earthing contact) Frequency $f \geq 50$ Hz or If L is correctly contacted and PE is interrupted (frequency $f \geq 50$ Hz)

Status	Error No.	Position of the Function Switch	Function/Meaning
<b>Error Messages— LCD Connection Pictographs</b>			
	Err1	All measurements with protective conductor	Potential difference $\geq U_L$ PE (earthing contact) (frequency $f \geq 50$ Hz) Remedy: Check PE connection. Note: Only if  is displayed: Measurement can nevertheless be started by pressing the ON/START key again.
	Err2	$I_{\Delta N} / I_{F\Delta}$ $Z_{L-N} / Z_{L-PE} / R_E$	1) Voltage too high ( $U > 253$ V) for RCD test with direct current 2) $U$ always $> 550$ V with 500 mA 3) $U > 440$ V for $I_{\Delta N} / I_{F\Delta}$ 4) $U > 253$ V for $I_{\Delta N} / I_{F\Delta}$ with 500 mA
	Err3	$I_{\Delta N}$	RCD is tripped too early or is defective. Remedy: Test circuit for bias current.
	Err4	$Z_{L-PE}$	RCD is tripped too early or is defective. Remedy: Test with "DC + positive half-wave".
	Err5	$I_{\Delta N} / I_{F\Delta}$	RCD tripped during touch voltage measurement. Remedy: Check selected nominal test current.
	Err6	EXTRA → PRCD	The PRCD has been tripped. Reason: Poor contact or defective PRCD
	Err7	All except for U	Externally accessible fuse is blown. The voltage ranges remain functional even if fuses have blown. <b>Special case, <math>R_{LO}</math>:</b> Interference voltage during measurement may result in a blown fuse. Remedy: Replace fuse. <b>Observe notes regarding fuse replacement in section 19.3!</b>
	Err8	$I_{\Delta N} / I_{F\Delta}$ $Z_{L-N} / Z_{L-PE} / R_E$	Frequency out of permissible range Remedy: Check the mains connection.
	Err9	All	Excessive temperature inside the test instrument Remedy: Wait for test instrument to cool down.
	Err9	$R_{INS} / R_{LO}$	Interference voltage Remedy: Device under test must be disconnected from all sources of voltage.
	Err11	$R_{INS} / R_{LO}$	Overvoltage or overloading of the measuring voltage generator during measurement of $R_{INS}$ or $R_{LO}$
	Err12	$I_{\Delta N} / I_{F\Delta}$ $Z_{L-N} / Z_{L-PE}$ $R_E$	No mains connection Remedy: Check the mains connection.
	Err13	$R_{LO}$	OFFSET measurement is not sensible. Remedy: Check system. OFFSET measurement of $R_{LO+}$ and $R_{LO-}$ is still possible.

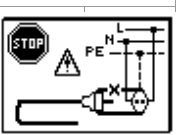
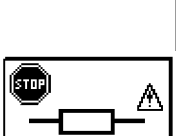
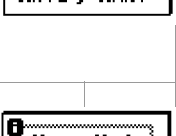
Status	Error No.	Position of the Function Switch	Function/Meaning																								
	Err14 pop_r-lo_lpe_n-pe_2_high	SETUP	Resistance compensation for the connector cables: $R_{\text{OFFSET}} > 1 \Omega$ : OFFSET measurement of RL-PE or RN-PE and RLN for ZL-PE and ZL-N is not sensible. Remedy: Check system.																								
	Err15	$R_{\text{LO}}$	$R_{\text{OFFSET}} > 10 \Omega$ : OFFSET measurement is not sensible. Remedy: Check system.																								
	Err16	SETUP → OFFSET (EXTRA → ΔU)	$Z > 10 \Omega$ : OFFSET measurement of RL-PE or RN-PE and RLN for ΔU(ZLN) is not sensible. Remedy: Check system.																								
	Err17	EXTRA → ΔU	$\Delta U_{\text{OFFSET}} > \Delta U$ : OFFSET value is greater than the measured value at the consuming system. OFFSET measurement is not sensible. Remedy: Check system.																								
	Err18 ril_ps_intro	RINS / RLO	Contact problem or blown fuse Remedy: Check test plug or measuring adapter for correct seating in the test plug, or replace the fuse.																								
	Err19 ch-g_prob_intro	$R_{\text{E}}$	Polarity of the test probes has to be reversed.																								
	Err20	$I_{\Delta\text{N}} / I_{\text{F}}$	N and PE are reversed.																								
	Err21 err_-main_intro	$I_{\Delta\text{N}} / I_{\text{F}}$ $Z_{\text{L-N}} / Z_{\text{L-PE}} / R_{\text{E}}$	1) Mains connection error Remedy: Check the mains connection. or 2) Display at the connection pictograph: PE interrupted (x) or underlying protective conductor bar interrupted with reference to the keys at the test plug Cause: <b>Voltage measuring path</b> interrupted Result: Measurement is disabled. Note: Only if  is displayed: Measurement can nevertheless be started by pressing the start key again ( <b>ON/START</b> ).																								
	Err22 pop_pe_i_intro	$I_{\Delta\text{N}} / I_{\text{F}}$	Display in the connection pictograph: Overlying protective conductor tab interrupted with reference to the keys at the test plug Cause: <b>Current measuring path</b> interrupted Result: No measured value display																								
	Err23	$I_{\Delta\text{N}} / I_{\text{F}}$	Resistance in N-PE path is too high. <table border="1" data-bbox="662 1590 1412 1713"> <thead> <tr> <th></th> <th colspan="5"><math>I_{\Delta\text{N}}/I_{\text{F}}</math></th> </tr> <tr> <th></th> <th>10 mA</th> <th>30 mA</th> <th>100 mA</th> <th>300 mA</th> <th>500 mA</th> </tr> </thead> <tbody> <tr> <td><math>R_{\text{MAX}}</math> at <math>I_{\Delta\text{N}}</math></td> <td>510 Ω</td> <td>170 Ω</td> <td>50 Ω</td> <td>15 Ω</td> <td>9 Ω</td> </tr> <tr> <td><math>R_{\text{MAX}}</math> for <math>I_{\text{F}}</math></td> <td>410 Ω</td> <td>140 Ω</td> <td>40 Ω</td> <td>12 Ω</td> <td>7 Ω</td> </tr> </tbody> </table> Consequence: The required test current cannot be generated and measurement is aborted.		$I_{\Delta\text{N}}/I_{\text{F}}$						10 mA	30 mA	100 mA	300 mA	500 mA	$R_{\text{MAX}}$ at $I_{\Delta\text{N}}$	510 Ω	170 Ω	50 Ω	15 Ω	9 Ω	$R_{\text{MAX}}$ for $I_{\text{F}}$	410 Ω	140 Ω	40 Ω	12 Ω	7 Ω
	$I_{\Delta\text{N}}/I_{\text{F}}$																										
	10 mA	30 mA	100 mA	300 mA	500 mA																						
$R_{\text{MAX}}$ at $I_{\Delta\text{N}}$	510 Ω	170 Ω	50 Ω	15 Ω	9 Ω																						
$R_{\text{MAX}}$ for $I_{\text{F}}$	410 Ω	140 Ω	40 Ω	12 Ω	7 Ω																						
	Err24	$Z_{\text{L-PE}}, R_{\text{E}}$	If specified touch voltage $U_{\text{L}}$ is exceeded: $Z_{\text{L-PE}}$ and $R_{\text{E}}$ : User is prompted to switch to the 15 mA wave.  $R_{\text{E}}$ alternative only: User is prompted to reduce the measuring range (reduce current.)																								

Status	Error No.	Position of the Function Switch	Function/Meaning
<b>Entry Plausibility Check – Parameters Combination Checking — LCD Pictographs</b>			
	Err25 error_para_out_of_range		Parameter out of permissible range
	Err26 error_5x500ma	$I_{\Delta N}$	$5 \times 500 \text{ mA}$ is not possible
	Err27 par_0000010	$I_{\Delta N} / I_F \triangle$	Types B/B+ and EV/MI not possible with G/R, SRCD, PRCD
	Err28 error_180°	$I_{\Delta N}$	$180^\circ$ not possible for G/R, SRCD, PRCD
	Err29 par_0000040_033	$I_{\Delta N} / I_F \triangle$	DC not possible with G/R, SRCD, PRCD
	Err30 par_0000080_033	$I_{\Delta N} / I_F \triangle$	Half-wave or DC not possible with type AC
	Err31 par_0000100_033	$I_{\Delta N} / I_F \triangle$	DC not possible with type A, F
	Err32 par_0000200_033	$I_{\Delta N}$	$\frac{1}{2}$ test current not possible with DC
	Err33 par_0000400_033	$I_{\Delta N}$	$2 \times / 5 \times I_{\Delta N}$ with full-wave only
	Err34 par_0000400_033	$I_{\Delta N} / I_F \triangle$	DC+ with $10 \Omega$ only
	Err35 par_0010000_033	$R_E$	15 mA only possible in $1 \text{ k}\Omega$ and $100 \Omega$ ranges!
	Err36 par_0020000_033	$R_E$	15 mA as loop measurement only
	Err37 error_d_parameter	All	The parameters you have selected do not make sense in combination with previously configured parameters. The selected parameter settings will not be saved. Remedy: Enter other parameters.



Status	Error No.	Position of the Function Switch	Function/Meaning
<b>Database and Entry Operations — LCD Pictographs</b>			
	Err38	$\frac{I_{\Delta N}}{Z_{L-N}} / \frac{I_F}{Z_{L-PE}}$ EXTRA → t <sub>A</sub> +I <sub>Δ</sub>	<p><b>Measured Value Storage with Deviating Electrical Circuit Parameter</b></p> <p>The electrical circuit parameter selected by yourself at the test instrument does <b>not</b> coincide with the parameter entered under object data in the structure.</p> <p><b>Example:</b> Residual operating current is specified as 10 mA in the database, but you have performed measurement with 100 mA. If you want to perform all future measurements with 100 mA, the value in the database has to be changed by acknowledging with the <input checked="" type="checkbox"/> key. The measured value is documented and the new parameter is accepted.</p> <p>If you want to leave the parameter in the database unchanged, press the <input type="checkbox"/> key. The measured value and the changed parameter are only documented in this case.</p>
	Err39	All	Please enter a designation (alphanumeric).
	Err40	All	<p>Operation with a Barcode Scanner</p> <p>Error message appears when the "EDIT" entry field is opened and rechargeable battery voltage is less than 8.0 V. Output voltage is generally switched off during barcode scanner operation if U is less than 8.0 V in order to assure that remaining battery capacity is adequate for entering designations for devices under test and saving the measurement.</p> <p>Remedy: Rechargeable batteries must be recharged, or batteries must be replaced towards the end of their service life.</p>
	Err41 pop_imax- _intro	All	<p>Operation with a Barcode Scanner</p> <p>Current flowing through the RS 232 port is too high.</p> <p>Remedy: <b>The connected device is not suitable for this port.</b></p>
	Err42	All	<p>Operation with a Barcode Scanner</p> <p>Barcode not recognized, incorrect syntax</p>
	Err43	All	<p>Data cannot be entered at this location within the structure.</p> <p>Remedy: Observe profile for preselected PC software (see SETUP menu)</p>
	Err44	All	<p>Measured value cannot be saved at this location within the structure.</p> <p>Remedy: Make sure that you have selected the right profile for you PC evaluation program in the SETUP menu (see section 8).</p>
	Err45	All	<p>Memory is full.</p> <p>Remedy: Save your measurement data to a PC and then clear memory at the test instrument by deleting the database or by importing an empty database.</p>
	Err46	All	<p>Delete measurement or database.</p> <p>This prompt window asks you to confirm deletion.</p>
	Err47	SETUP	<p><b>Data loss after changing language or profile, or after restoring default settings.</b></p> <p>Back up your measurement data to a PC before pressing the respective key.</p> <p>This prompt window asks you to confirm deletion.</p>
	Err48	All	<p>This error message appears if the database, i.e. the structure created in ETC, is too large for the instrument's internal memory.</p> <p>The database in the instrument's internal memory is empty after database transfer has been interrupted.</p> <p>Remedy: Reduce the size of the database in ETC or transfer the database without measured values (<b>Transmit Structure</b> key), if measured values already exist.</p>

## 7 Operation



### Attention!

Remove the protective foil from the key **ON/START** (finger contact).  
This is the only way to reliably detect touch voltage.

### 7.1 Power Supply

The instrument is powered by (rechargeable) batteries.  
Operation is possible using the supplied battery pack with commercially available, individual (rechargeable) batteries or a battery pack (Z502H 2000 mAh<sup>1)</sup> or Z505U 2620 mAh).  
One of these options must be implemented before initial startup (see condensed operating instructions).



### Note

If at all possible, use the included battery pack or optionally available rechargeable battery pack (Z502H/Z502O) with sealed cells.  
This ensures that the complete set of rechargeable batteries is always replaced at the same time and that all batteries are inserted with correct polarity, in order to assure that they do not fail.

### Notes Concerning the Battery Pack

The battery pack is a holder into which commercially available, individual (rechargeable) batteries are inserted.



### Attention!

Make sure that all of the (rechargeable) batteries are inserted with correct polarity!  
If just one battery is inserted with reversed polarity, it will not be recognized by the instrument and may result in leakage from the (rechargeable) batteries.



### Attention!

Individual rechargeable batteries may only be recharged externally.



### Attention!

Commercially available, individual (rechargeable) batteries must comply with the technical data (see page 9).

### 7.1.1 Installing or Replacing the (Rechargeable) Battery Pack



### Attention!

Before opening the battery compartment, disconnect the instrument from the measuring circuit (mains) at all poles!

- ⇨ Loosen the slotted screw for the rechargeable battery compartment lid on the back and remove the lid.
- ⇨ Remove the depleted (rechargeable) battery pack.
- ⇨ Insert the new rechargeable battery pack or battery pack with fresh batteries into the battery compartment.  
Insertion is only possible with correct orientation.
- ⇨ Replace the battery compartment lid and re-tighten the screw.



### Note

Dispose of the rechargeable battery pack, or the individual rechargeable batteries or commercially available, individual batteries in an environmentally sound fashion when their service life has nearly expired (approx. 80% charging capacity). See Section 22, "Disposal and Environmental Protection", beginning on page 58.

### 7.1.2 (Rechargeable) Battery Test

If (rechargeable) battery voltage has fallen below the allowable lower limit, the pictograph shown at the right appears. "Low Batt!!!" is also displayed along with a (rechargeable) battery symbol. The instrument does not function in the case of excessive depletion and no display appears.



### Note

After the period of time selected in the **SETUP** menu has elapsed, the instrument is switched off automatically in order to conserve electrical power (see "Device Settings" in section 8).

### 7.1.3 Charging the Battery Pack (Z502H/Z505U) in the Test Instrument

The optionally available battery packs (Z502H 2000 mAh<sup>1</sup> or Z505U 2620 mAh) can be charged directly in the instrument.



### Attention!

Only rechargeable battery packs listed as accessories (Z502H/Z505U) may be charged with the Z502R charger!  
Normal batteries cannot be charged.  
Danger of explosion!  
No individual batteries or other battery packs etc. may be charged.  
The quality of such batteries cannot be checked and they may overheat, thus resulting in deformation, leakage, bursting and damage to the instrument.



### Attention!

Use only the Z502R charger in order to recharge the compact battery pack (Z502H/Z505U) in the test instrument.



### Attention!

Before charging the battery pack, disconnect the test instrument from the measuring circuit (mains) at all poles!



### Attention!

The Z502R charger is suitable for mains operation only!



### Attention!

Do not switch the test instrument on during charging. The charging process may otherwise be impaired.

- ⇨ Verify that an approved battery pack (Z502H/Z505U) has been inserted, i.e. that commercially available battery packs or batteries are not inserted.
- ⇨ Insert the correct mains plug for your country into the charger Z502R.
- ⇨ Connect the Z502R charger to the test instrument with the jack plug, and then to the 230 V mains with the interchangeable plug.
- ⇨ Please refer to the operating instructions included with the charger regarding the meanings of LED displays during the charging process.
- ⇨ Do not disconnect the charger from the test instrument until the green LED (charged/ready) lights up.

### If the battery pack has not been used or recharged for a lengthy period of time (> 1 month), thus resulting in excessive depletion:

Observe the charging sequence (indicated by LEDs at the charger) and initiate a second charging sequence if necessary (disconnect the charger from the mains and from the test instrument to this end, and then reconnect it).

Please note that the system clock stops in this case and must be set to the correct time after the instrument has been restarted.

<sup>1)</sup> Available until end of 2023. Replaced by Z505U battery pack.

## 7.2 Switching the Instrument On/Off

The test instrument is switched on by pressing the **ON/START** key. The menu which corresponds to the momentary selector switch position is displayed.

The instrument can be switched off manually by simultaneously pressing the **MEM** and **HELP** keys.

## 7.3 Attaching the Test Probe Holders to the Carrying Strap

The test probe holders are only available from our service department (see section 20).

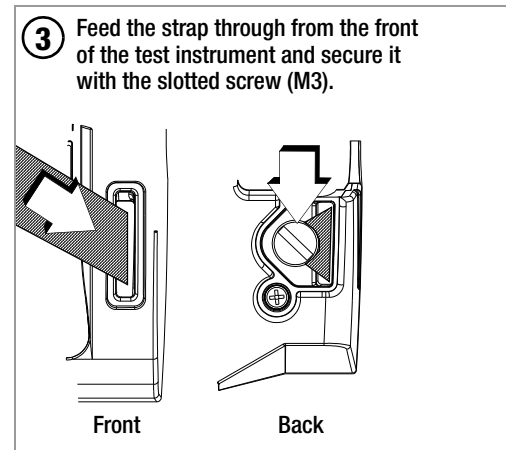
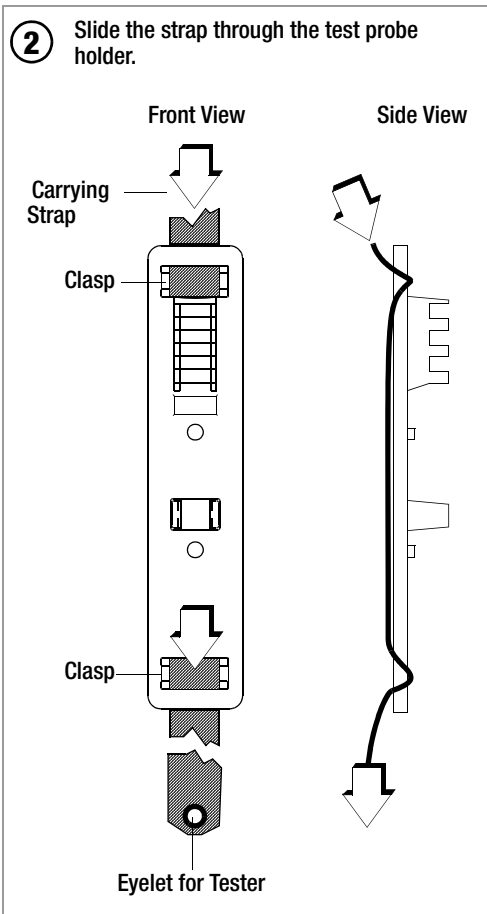
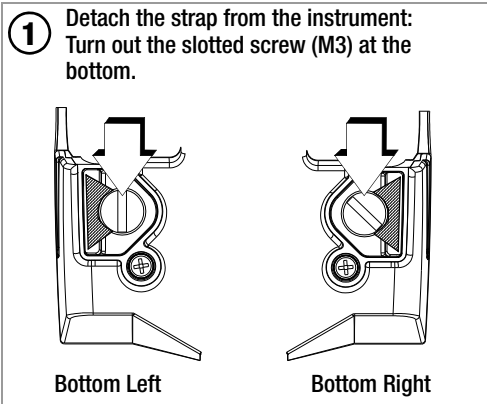

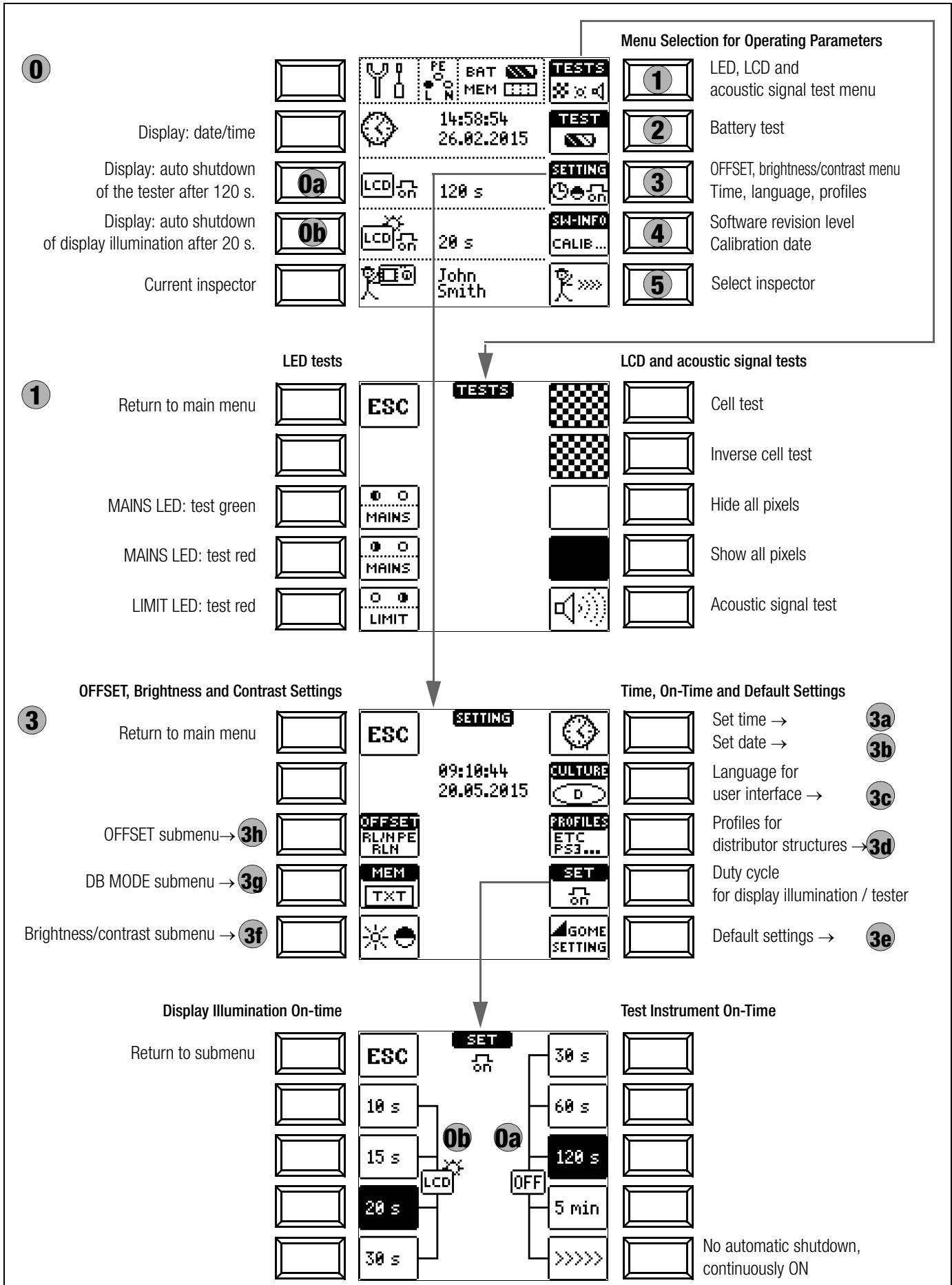

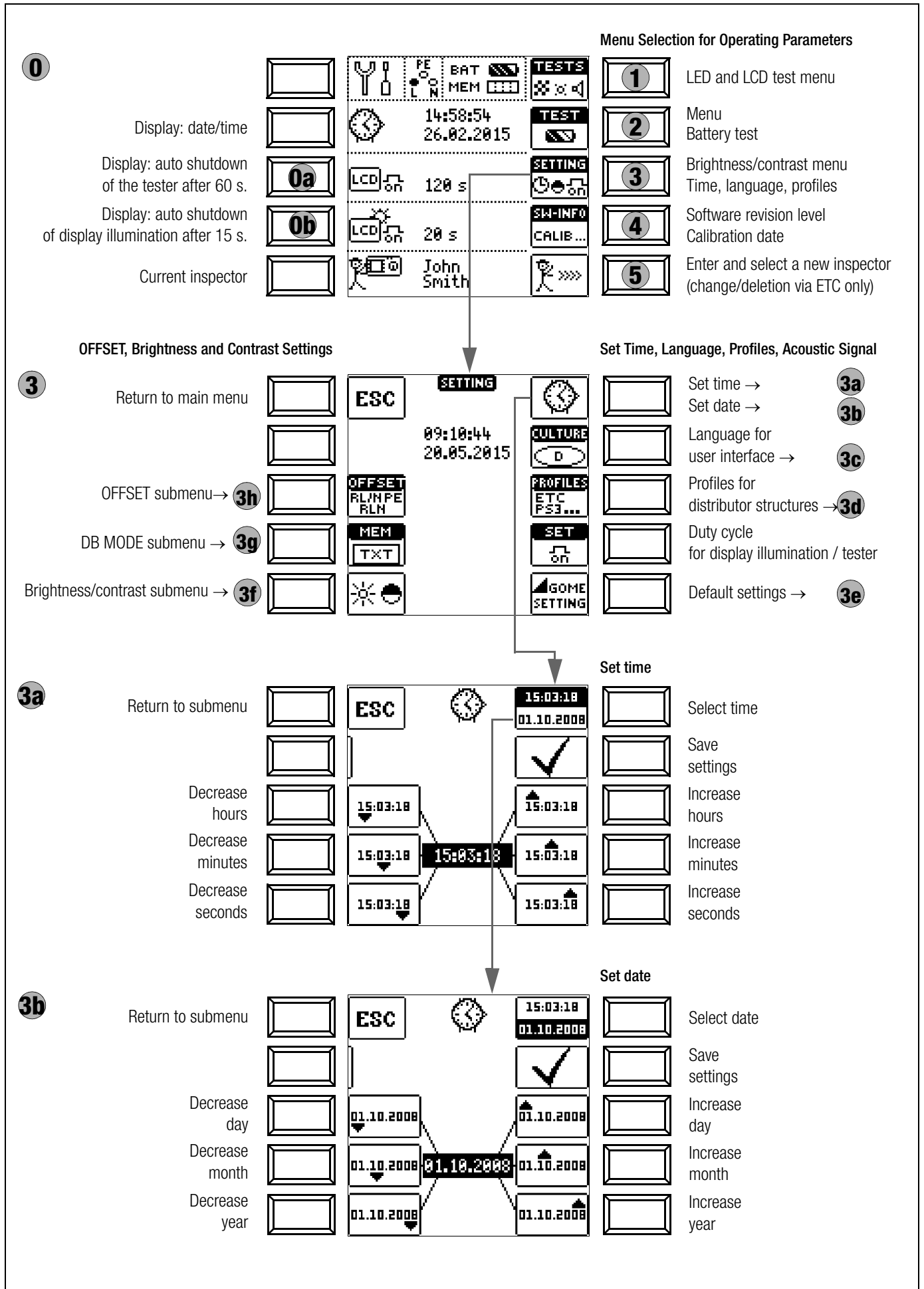

## Significance of Individual Parameters

### 0a Test Instrument On-Time

The period of time after which the test instrument is automatically shut off can be selected here. This selection has a considerable influence on the service life and/or the charging status of the batteries, the rechargeable batteries or the battery pack.

### 0b LCD Illumination On-Time

The period of time after which LCD illumination is automatically shut off can be selected here. This selection has a considerable influence on the service life and/or the charging status of the batteries, the rechargeable batteries or the battery pack.

#### Submenu: (Rechargeable) Battery Level Query

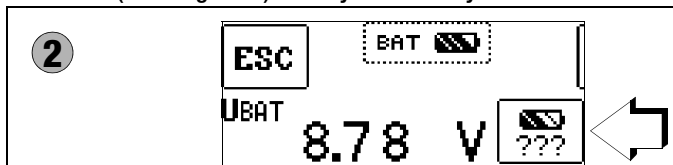

If (rechargeable) battery voltage has dropped to 8.0 V or less, the LIMIT LED lights up red and an acoustic signal is generated as well.

#### Note

##### Measuring Sequence

If (rechargeable) battery voltage drops to below 8.0 V during the course of a measuring sequence, this is only indicated by means of a pop-up window. Measured values are invalid. The measurement results cannot be saved to memory.



➤ Press **ESC** in order to return to the main menu.

#### Attention!

**Data, including sequences, are lost when the language, the profile or the DB MODE is changed, or if the instrument is reset to default values!**

Back up your structures and measurement data to a PC before pressing the respective key.

The prompt window shown at the right asks you to confirm deletion.



### 3c User Interface Language (CULTURE)

➤ Select the desired country setup with the appropriate country code.

**Caution: All structures and data will be deleted (see note above)!**

### 3d Profiles for Distributor Structures (PROFILES)

The profiles are laid out in a tree structure. The tree structure for the utilized PC evaluation program may differ from that of the PROFITEST INTRO. For this reason, the PROFITEST INTRO provides the user with the opportunity of adapting this structure. Selecting a suitable profile determines which object combinations are made possible. For example, this makes it possible to create a distributor which is subordinate to another or to save a measurement to a given building.

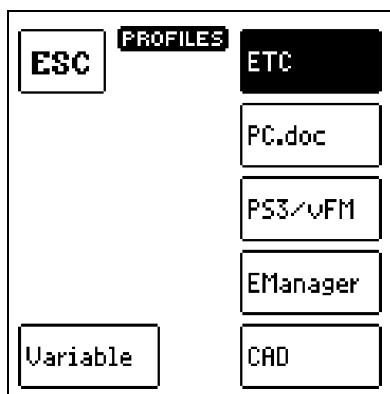

➤ Select the PC evaluation program you intend to use.

**Caution: All structures and data will be deleted (see note above)!**

If you haven't selected a suitable PC evaluation program and, for example, if measured value storage to the selected location within the structure is not possible, the pop-up window shown at the right appears.

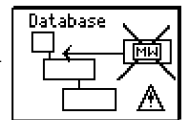

### 3e Default Settings (GOME SETTING)

The test instrument is returned to its original default settings when this key is activated.

**Caution: All structures and data will be deleted (see note above)!**

### 3f Adjusting Brightness and Contrast

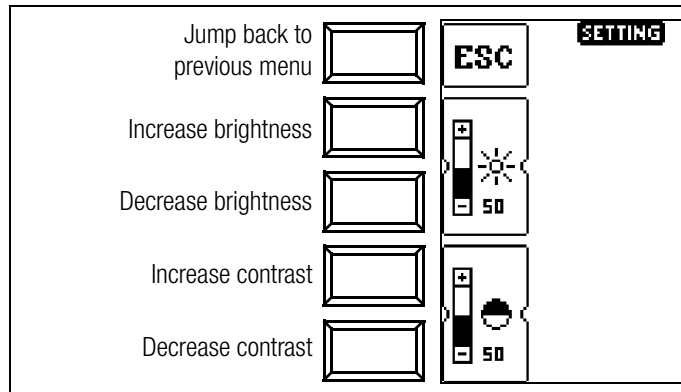

### 3g DB MODE – Database Display in the Text or ID Mode

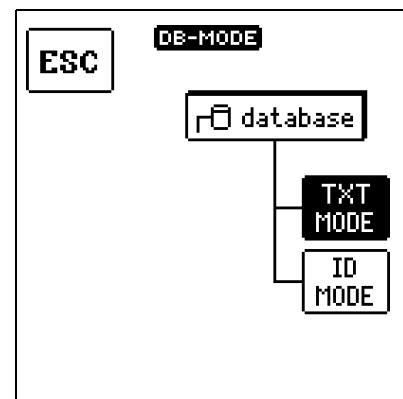

#### Creating Structures in the TXT MODE

The database in the test instrument is set to the text mode as a default feature and "TXT" appears in the header. You can create structure elements in the test instrument and label them in plain text, e.g. Customer XY, Distributor XY and Circuit XY.

#### Creating Structures in the ID MODE

You can work in the ID MODE as an alternative, in which case "ID" appears in the header. You can create structure elements in the test instrument and label them with any desired ID numbers.

#### Note

When transferring data from the test instrument to ETC at a PC, ETC always uses the same representation as the test instrument (TXT or ID mode).

When transferring data from ETC at the PC to the test instrument, the test instrument always uses the same representation as ETC.

In other words, the respective data recipient always uses the same representation as the data transmitter.

#### Note

Structures can be created in the test instrument in either the text mode or the ID mode.

In contrast, designations and ID numbers are always assigned in ETC.

If no texts or ID numbers have been entered to the test instrument when creating structures, ETC generates the missing entries automatically. These can then be edited in ETC and transferred back to the test instrument if required.

### 3h OFFSET $R_{L-PE}$ / $R_{N-PE}$ / $R_{L-N}$

For the measurement of  $Z_{L-PE}$ ,  $Z_{L-N}$ , RE and  $\Delta U(Z_{LN})$ , ohmic offset values

$R_{L-PE}$ ,  $R_{N-PE}$  and  $R_{L-N}$  can be ascertained here, which then appear in the footers of the corresponding measuring menu pages and are subtracted from the measured values.

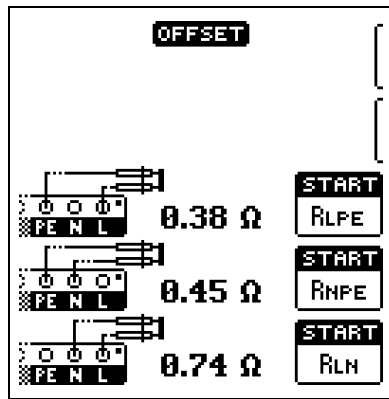

- Connect the measurement cables to the respective inputs and short circuit the test probes by inserting the test plug into the short-circuiting jumper (PRO-JUMPER, Z503J).
- Start offset measurement by pressing the respective **START** key.

The respective offset value cannot be activated or deactivated, i.e. set to 0, unless all settings are returned to their default values. There's a separate offset value for **RLO**, which can be ascertained directly in the **RLO** switch position.



#### Note

##### Measurement of $R_{L-PE}$ or $R_{N-PE}$

In the event that phase voltage could be applied to L or N at the test probe or the measuring adapter during future measurements, both offset values must be determined here accordingly. Depending on the connection, the corresponding offset value is then displayed later in the measuring menu. If no phase voltage is applied, **R<sub>L-PE</sub>** is displayed by default.



#### Note

##### In order to ascertain the $R_{LN}$ -OFFSET value for the measurement of $\Delta U(Z_{LN})$ :

Connect the test probe to the point of common coupling (measuring device / meter).

### 4 Software/Firmware Version and Calibration Information (example)

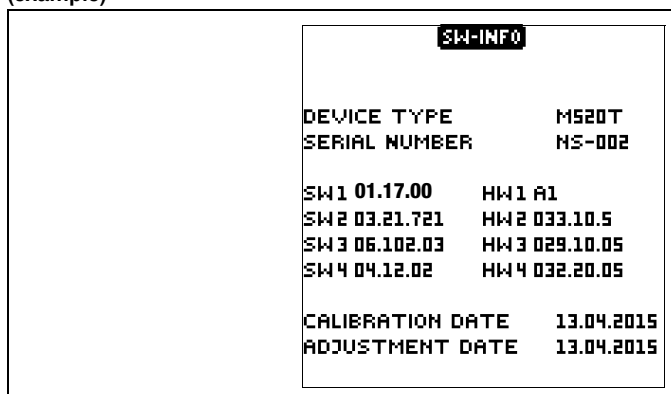

- Press any key in order to return to the main menu.

### Firmware/Software Update

The layout of the test instruments makes it possible to adapt device software to the latest standards and regulations. Beyond this, suggestions from customers result in continuous improvement of the test instrument software, as well as new functions.

The user interface can be set to either English, German or Italian. Please contact GMC-I Service GmbH for updates. See Section 20, "Contact, Support and Service", beginning on page 57.

### 5 Entering and Selecting a New Inspector

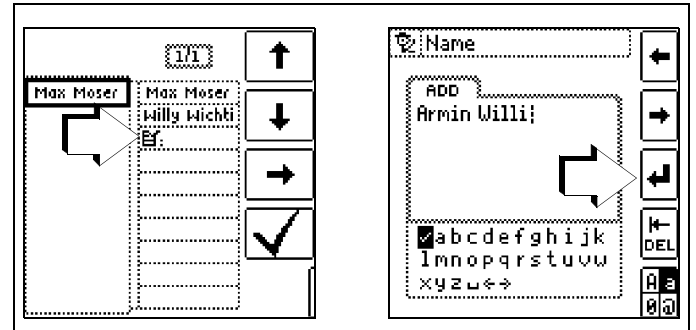

See also section 10.8 on page 32 regarding the entry of a text.

## 9 Database, Saving Data and Generating Reports

### 9.1 Creating Distributor Structures, General

A complete distributor structure with data for electrical circuits and RCDs can be created in the PROFITEST INTRO test instrument. This structure makes it possible to assign measurements to the electrical circuits of various distributors, buildings and customers.

There are two possible procedures:

- On location at construction site: Create a distributor structure in the test instrument. A distributor structure with up to 50,000 structure elements can be created in the test instrument, which is saved to the instrument's flash memory.

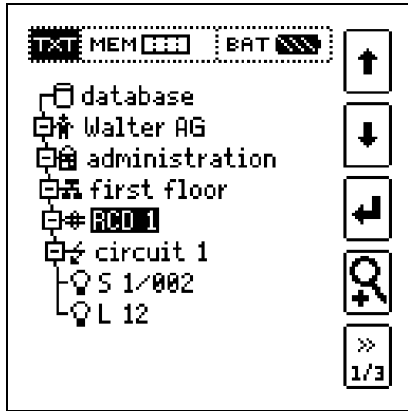

or

- Create and save an image of an existing distributor structure at a PC with the help of **ETC report generating software** (Electric Testing Center) – see Help > Getting Started (F1). The distributor structure is then transferred to the test instrument.

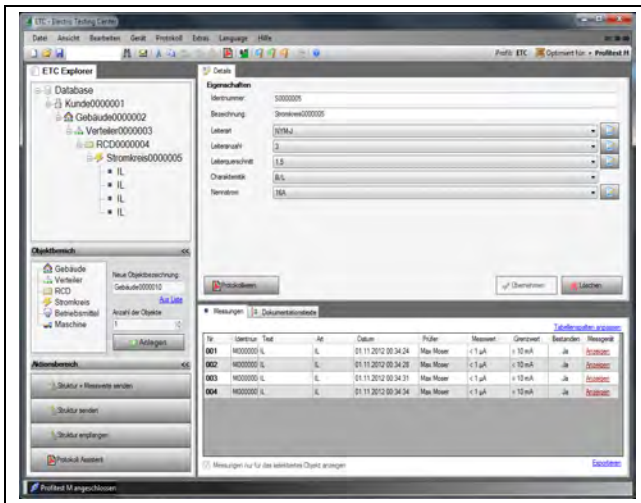

#### Note regarding ETC Report Generating Software

The following steps must be completed before using the software:

- Install the USB device driver** (required for operation of the PROFITEST INTRO at a PC): **GMC-I Driver Control** software for installing the USB device driver can be downloaded from our website: <http://www.gossenmetrawatt.com> → Products → Software → Software for Testers → Utilities → **Driver Control**
- Install ETC report generating software:** The most up-to-date version of ETC can be downloaded free of charge from the **mygmc** page of our website as a ZIP file, if you have registered your test instrument:

<http://www.gossenmetrawatt.com>  
 → Products → Software → Software for Testers  
 → Report Software without Database → **ETC** → **myGMC** → **to Login**

### 9.2 Transferring Distributor Structures

The following data transfer operations are possible:

- Transfer a distributor structure from the PC to the test instrument.
- Transfer a distributor structure including measured values from the test instrument to the PC.

The test instrument and the PC must be connected with a USB cable in order to transfer structures and data.

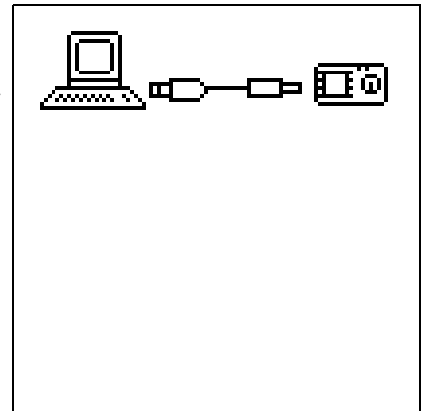

The following image appears at the display during transfer of structures and data.

### 9.3 Creating a Distributor Structure in the Test Instrument

#### Overview of the Meanings of Icons used to Create Structures

Icon	Meaning
Main Level	Sub-level
<b>Memory Menu, Page 1 of 3</b>	
	Cursor UP: scroll up
	Cursor DOWN: scroll down
	ENTER: Acknowledge selection. + → - change to sub-level (open directory) or - → + change to main level (close directory)
	Display the complete structure designation (max. 63 characters) or ID number (25 characters) in a zoom window.
	Temporarily switch back and forth between structure designation and ID number. These keys don't have any effect on the main setting in the setup menu (see "DB Mode" on page 22).
	Hide the zoom window.
	Change display to menu selection.
<b>Memory Menu, Page 2 of 3</b>	
	Add a structure element.
	Meaning of icons from top to bottom: Customer, building, distributor, RCD, electrical circuit, operating equipment, machine and earth electrode (display of the icons depends on the selected structure element). Selection: UP/DOWN scroll keys and ↵ In order to add a designation to the selected structure element, refer to the edit menu in following column.
EDIT	For additional icons see edit menu below.



Icon	Meaning
	Delete the selected structure element.
	Show measurement data, if a measurement has been performed for this structure element.
	Edit the selected structure element.
<b>Memory Menu, Page 3 of 3</b>	
	Search for ID number. > Enter complete ID number.
	Search for text. > Enter full text (complete word).
	Search for ID number or text.
	Continue searching.
<b>Edit Menu</b>	
	Cursor LEFT: Select an alphanumeric character.
	Cursor RIGHT: Select an alphanumeric character.
	ENTER: accept an individual character.
<input checked="" type="checkbox"/>	Acknowledge entry.
←	Scroll left.
→	Scroll right.
	Delete character.
	Switching amongst different types of alphanumeric characters:
A	✓ABCDEFGHIJK Upper case letters LMNOPQRSTUVWXYZ XYZ↵⇐⇒
a	✓abcdefghijk Lower case letters lmnopqrstuvwxyz xyz↵⇐⇒
0	✓0123456789+ Numbers -*/=:;_ ( ) < > . ! ? ↵⇐⇒
@	✓@#Aa00UuB€\$% Special characters &#sááééííóóúú ñ Ñæ↵⇐⇒

## Distributor Structure Symbology / Tree Structure

A **check mark** to the right of a structure element means that all measurements within the respective hierarchy have been passed.

**x:** At least one measurement has not been passed.

**No symbol:** Measurement has not yet been performed.

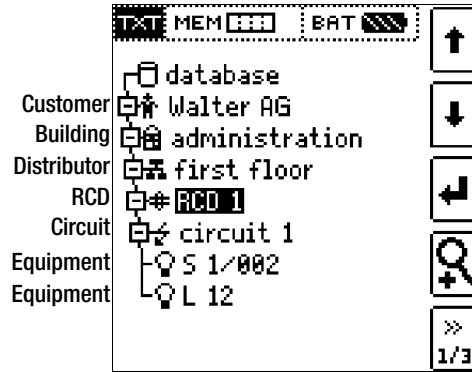

Same type of element as in the Windows Explorer:

+: sub-objects available, display by pressing ↵.

-: sub-objects are displayed, hide by pressing ↵.

### 9.3.1 Creating Structures (example for electrical circuit)

After selection with the **MEM** key, all setting options for the creation of a tree structure are made available on three menu pages (1/3, 2/3 and 3/3). The tree structure consists of structure elements, referred to below as objects.

#### Selecting the Position at which a New Object will be Added

Scroll up  
 Scroll down  
 Acknowledge selection / change level  
 Display object or ID number  
 Next page

Use the ↑↓ keys in order to select structure elements.

Change to the sub-level with the ↵ key.

Go to the next page with the >> key

#### Creating a New Object

Create object  
 Edit designation  
 VQA: Show measurement data  
 Delete object

Press the key in order to create a new object.

## Selecting a New Object From a List

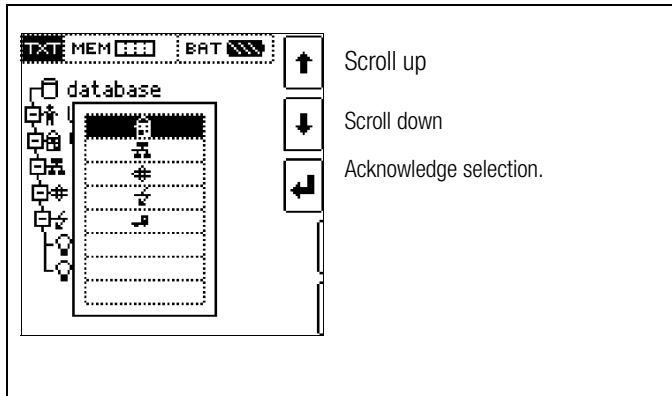

- ↑ Scroll up
- ↓ Scroll down
- ↵ Acknowledge selection.

Select the desired object from the list with the ↑↓ keys and acknowledge with the ↵ key.

Depending upon the profile selected in the test instrument's SETUP menu (see section 8), the number of object types may be limited, and the hierarchy may be laid out differently.

## Entering a Designation

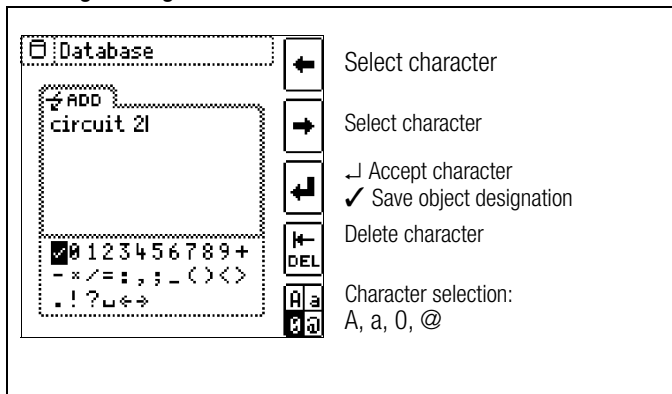

- ← Select character
- Select character
- ↵ Accept character
- ✓ Save object designation
- ↵ Delete character
- Character selection:  
A, a, 0, @

Enter a designation and then acknowledge it by pressing ✓.



### Note

Acknowledge the default parameters shown below or the adjusted parameters, because the created designation will otherwise not be accepted and saved.

## Setting Electrical Circuit Parameters

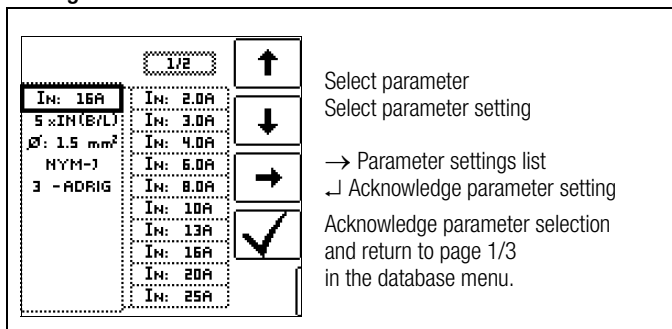

- ↑ Select parameter
- ↓ Select parameter setting
- → Parameter settings list
- ↵ Acknowledge parameter setting
- ✓ Acknowledge parameter selection and return to page 1/3 in the database menu.

For example, nominal current values must be entered here for the selected electrical circuit. Measuring parameters which have been accepted and saved in this way are subsequently accepted by the current measuring menu automatically when the display is switched from the structure view to measurement.



### Note

Electrical circuit parameters changed during structure creation are also retained for individual measurements (measurement without saving data).

**If you change the electrical circuit parameters specified by the structure in the test instrument, a warning is displayed when the change is saved (see error message on page 17).**

## 9.3.2 Searching for Structure Elements

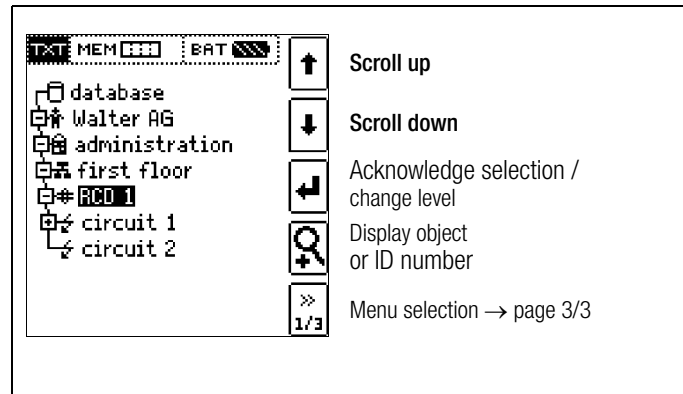

- ↑ Scroll up
- ↓ Scroll down
- ↵ Acknowledge selection / change level
- 🔍 Display object or ID number
- Menu selection → page 3/3

Regardless of the currently selected object, the search is started at **database**.

Go to Page 3/3 in the Database Menu.

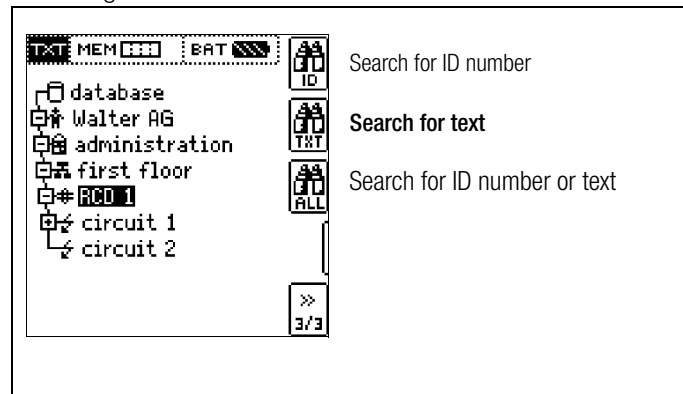

- ID Search for ID number
- TXT Search for text
- ALL Search for ID number or text

After selecting text search ...

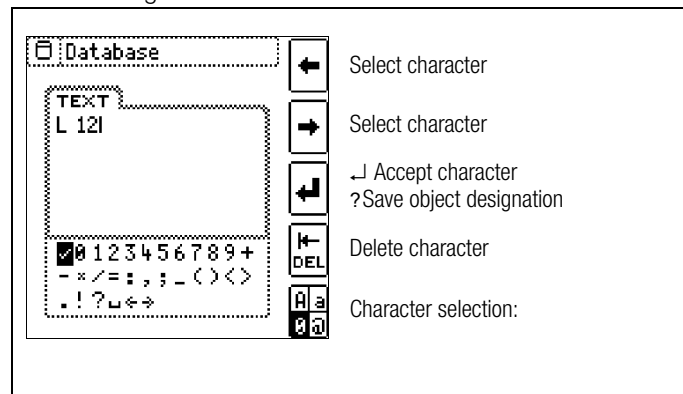

- ← Select character
- Select character
- ↵ Accept character
- ? Save object designation
- ↵ Delete character
- Character selection:

... and entering the desired text (only full matches are found – no wild cards, case sensitive) ...

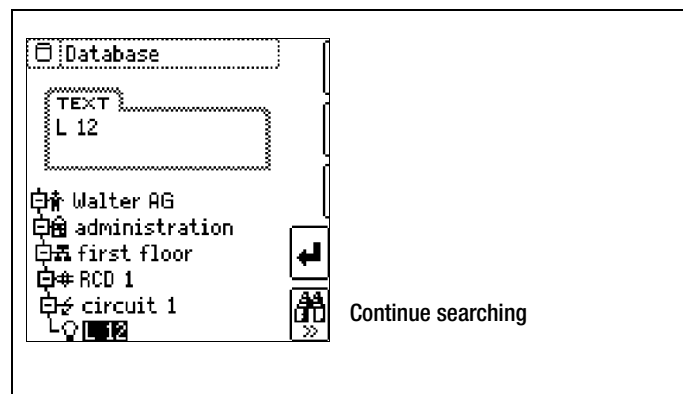

- Continue searching

... the first match is displayed.

Further matches can be found by selecting the icon shown at the right.



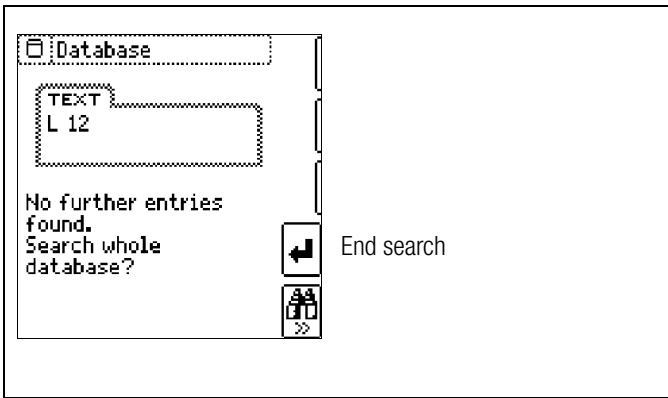

If no further matches are found, the message shown above is displayed.

## 9.4 Saving Data and Generating Reports

### Preparing and Executing a Measurement

Measurements can be performed and stored to memory for each structure element. Proceed as follows, adhering to the prescribed sequence:

- Select the desired measurement with the rotary knob.
  - Start the measurement by pressing the **ON/START** or  $I_{\Delta N}$  key.
- Upon completion of measurement, the "→ floppy disk" softkey is displayed.

- **Briefly** press the "Save Value" key.



The display is switched to the memory menu or the structure view.

- Navigate to the desired memory location, i.e. to the desired structure element / object, for which the measurement data will be saved.
- If you would like to save a comment along with the measurement, press the key shown at the right and enter a designation via the "EDIT" menu as described in section 9.3.1.
- Complete data storage by pressing the "STORE" key.



### Saving Error Messages (pop-ups)

If a measurement is ended without acquiring a measured value due to an error, the measurement can be saved along with the pop-up by pressing the "Save Value" key. The corresponding text is read out in ETC instead of the pop-up symbol. This only applies to a limited number of pop-ups (see below). Neither a symbol nor a text can be accessed in the test instrument's database itself.

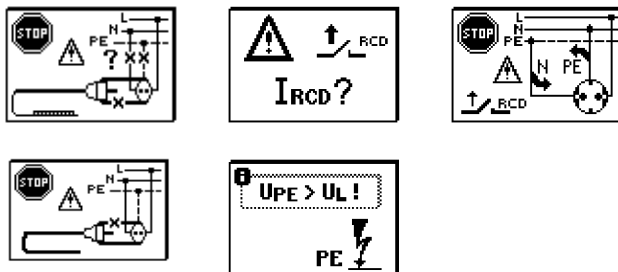

### Alternative Storage Procedure

- The measured value can be saved to the last selected object in the structure diagram by **pressing and holding** the "Save Value" key, without switching the display to the memory menu.



### Note

If you change the parameters in the measurement view, they're not saved for the structure element. A measurement with changed parameters can nevertheless be saved to the structure element, and any changed parameters are documented in the report for each measurement.

### Retrieving Saved Measured Values

- Switch the display to the distributor structure by pressing the **MEM** key and select the desired electrical circuit with the scroll keys.
- Switch to page 2 by pressing the key shown here:
- Display the measurement data by pressing the key shown here:



One measurement with date and time, as well as any comment you might have entered, is displayed in each screen.

Example:  
RCD measurement

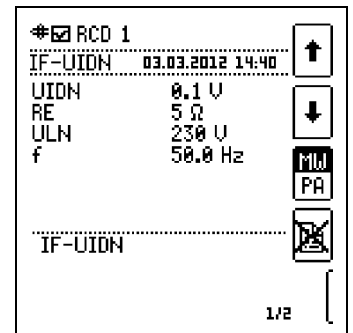

### Note

A check mark in the header means that the respective measurement has been passed. An X means that the measurement has not been passed.

- Scrolling amongst measurements is possible with the keys shown here:
- The measurement can be deleted with the key shown here:



A prompt window asks you to confirm deletion.



With the help of the key shown at the right (MV: measured value / PA: parameter) the setting parameters can be displayed for this measurement.

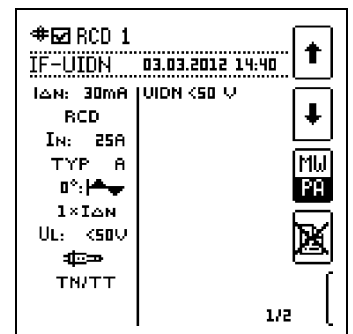

- Scrolling amongst measurements is possible with the keys shown here:



## 9.5 Data Evaluation and Report Generation with ETC Software

All data, including the distributor structure, can be transferred to the PC and evaluated with the help of ETC software. Additional information can be entered here subsequently for the individual measurements. After pressing the appropriate key, a report including all measurements within a given distributor structure is generated, or the data are exported to an Excel spreadsheet.



### Note

The database is exited when the rotary selector switch is turned. Previously selected parameters in the database are not used for the measurement.

---

## 9.6 Use of Barcode Scanners and RFID Readers

### Search for an Already Scanned Barcode

The search can be started from any switch setting and menu.

- ⇨ Scan the object's barcode.

The recognized barcode is displayed inversely.

- ⇨ This value is accepted after pressing the ENTER key.
- 



### Note

A previously selected object is not taken into consideration by the search.

---

### Continued Searching in General



Regardless of whether or not an object has been found, searching can be continued by pressing this key:

- Object found: Searching is continued below the previously selected object.
- No further object found: The entire database is searched at all levels.

### Reading In a Barcode for Editing

If the menu for alphanumeric entry is active, any value scanned by means of a barcode scanner or RFID reader is accepted directly.

### Using a Barcode Printer (accessory)

A barcode printer facilitates the following applications:

- Read-out of ID numbers as barcodes – for quick and convenient acquisition during periodic testing
- Print-out of repeatedly occurring designations such as test object types encrypted as barcodes in a list, allowing them to be read in as required for comments

## 10 General Notes Concerning Measurements

### 10.1 Using Cable Sets and Test Probes

- KS-PROFITEST INTRO (Z503L)
- Remote control with measurement key (Z550A), optional accessory



#### Attention!

**Observe the instrument's maximum values for electrical safety.** Measurements per DIN EN 61010-031 may only be performed in environments in accordance with measuring categories III and IV with the safety cap attached to the test probe at the end of the measurement cable.

In order to establish contact inside 4 mm jacks, the safety caps have to be removed by prying open the snap fastener with a pointed object (e.g. the other test probe).

### 10.2 Connecting the Instrument

For systems with earthing contact sockets, connect the instrument to the mains with the KS-PROFITEST INTRO test probes (Z503L) or with the PRO-Schuko measuring adapter (Z503K). Voltage between phase conductor L and protective conductor PE may not exceed 253 V!

Poling at the socket need not be taken into consideration. The instrument detects the positions of phase conductor L and neutral conductor N, and automatically reverses polarity if necessary. This does not apply to the following measurements:

- Voltage measurement in switch position U
- Insulation resistance measurement
- Low-value resistance measurement

If measurement is to be performed at three-phase outlets, in distribution cabinets or at permanent connections, use the cable set with KS-PROFITEST INTRO test probes (Z503L) (2-pole), and for phase sequence testing (3-pole). Connection is established with the test probes: one at PE or N and the other at L.

### 10.3 Automatic Settings, Monitoring and Shutdown

The test instrument automatically selects all operating conditions which it's capable of determining itself. It tests line voltage and frequency. If these lie within their valid nominal ranges, they appear at the display panel. If they are not within nominal ranges, prevailing voltage (U) and frequency (f) are displayed instead of  $U_N$  and  $f_N$ .

#### Measurement of Touch Voltage via Finger Contact

When a measurement is started and if you touch the **ON/START** key with your finger, the test instrument detects whether or not dangerous touch voltage  $U_b$  is present at the PE terminal relative to ground.

#### Error in the U Switch Position:

**PE** appears and the **LIMIT LED** lights up red.

#### Error in All Switch Positions Other than U:

The test instrument disables the measurement and the following message appears: **U.PE > UL!**

Prerequisites for reliable finger contact measurement:

- 8 Nothing is plugged into the interfaces and the charging cable is not plugged in.
- 9 Based on his standing surface, the user has an earth resistance of  $R_{eb} < 1 \text{ M}\Omega$ .
- 10 While starting the measurement, the user touches the **"ON/START"** key with an unprotected finger with full, direct skin contact.

### Insufficient Supply Voltage

If (**rechargeable**) **battery voltage** falls below the allowable limit value the instrument cannot be switched on, or it's immediately switched off.



#### Note

Performance of ZLOOP DC+ (DC-H), RCD IF $\blacktriangleleft$  and RCD IAN measurements with DC test current is only recommended with a battery charge level of  $\geq 50\%$ .

### Conditions Resulting in Disabling and Abortion of Measurements

The measurement is interrupted automatically, or the measuring sequence is blocked (except for voltage measuring ranges and phase sequence testing) in the event of:

- Impermissible line voltages ( $< 60 \text{ V}$ ,  $> 253 \text{ V}$  /  $> 330 \text{ V}$  /  $> 440 \text{ V}$  or  $> 550 \text{ V}$ ) for measurements which require line voltage
- Interference voltage during insulation resistance or low resistance measurements
- Overheating at the instrument  
As a rule, excessive temperatures only occur after approximately 50 measurement sequences at intervals of 5 seconds, when the rotary selector switch is set to the  $Z_{L-PE}$  or  $Z_{L-N}$  position.  
If an attempt is made to start a measuring sequence, an appropriate message appears at the display panel.

### Automatic Instrument Shutdown

The instrument only switches itself off automatically after completion of an automatic measuring sequence, and after the predetermined on-time has expired (see section 7.2). On-time is reset to its original value as defined in the setup menu, as soon as any key or the rotary selector switch is activated.

The instrument remains on for approximately 75 s in addition to the preset on-time for measurements with rising residual current in systems with selective RCDs.

The instrument always shuts itself off automatically, unless the following setting has been selected in SETUP: " $>>>>>$ " (continuously on).

### 10.4 Measured Value Display and Memory

The following items appear at the display panel:

- Measured values with abbreviations and units of measure
- Selected function
- Nominal voltage
- Nominal frequency
- Error messages

Measured values for automatic measuring procedures are stored and displayed as digital values until the next measurement sequence is started, or until automatic shutdown occurs.

If the upper range limit is exceeded, the upper limit value is displayed and is preceded by the " $>$ " symbol (greater than), which indicates measured value overrun.



#### Note

The depiction of LEDs in these operating instructions may vary from the LEDs on the actual instrument due to product improvements.

### 10.5 Testing Earthing Contact Sockets for Correct Connection

The testing of earthing contact sockets for correct connection prior to protective measures testing is simplified by means of the instrument's error detection system.

The instrument indicates improper connection as follows:

- **Impermissible line voltage ( $< 60 \text{ V}$  or  $> 253 \text{ V}$ ):**  
The **MAINS/NETZ LED** blinks red and the measuring sequence is disabled.

- **Protective conductor not connected or potential to earth  $\geq 50\text{ V}$  at  $\geq 50\text{ Hz}$**  (switch position U – single-phase measurement):  
If the contact surface of the **START** key is touched (**finger contact**) while PE is being contacted (via the country-specific measuring adapter, e.g. Z503K PRO-Schuko measuring adapter, as well as via the test probe in the case of 2-pole measurement with the Z503L KS-PROFITEST INTRO), PE appears (only after starting the test sequence). The **MAINS LED** blinks red as well.
- **Neutral conductor N not connected** (during mains dependent measurements):  
The **MAINS/NETZ LED** blinks green
- **One of the two protective contacts is not connected:**  
This is checked automatically during testing for touch current  $U_{I\Delta N}$ . Poor contact resistance at one of the contacts leads to one of the following displays depending upon poling of the plug:

– **Display in the connection pictograph:**

PE interrupted (x), or the underlying protective conductor tab interrupted with reference to the keys at the test plug

**Cause:** Voltage measuring path interrupted  
**Consequence:** measurement is disabled

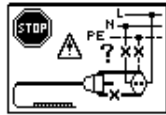

– **Display in the connection pictograph:**

Overlying protective conductor tab interrupted with reference to the keys at the test plug

**Cause:** current measuring path interrupted  
**Result:** no measured value display

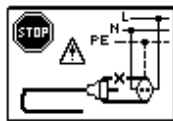

**Note**

See also “LED Indications, Mains Connections and Potential Differences” beginning on page 12.



**Attention!**

Reversal of N and PE in a system without RCCBs cannot be detected and is not indicated by the instrument. In systems including an RCCBs, the RCCB is tripped during touch voltage measurement without RCCB tripping (automatic  $Z_{L-N}$  measurement), insofar as N and PE are reversed.

**10.6 Help Function**

The following information can be displayed for each switch position and basic function **after it has been selected with the** rotary selector switch:

- Wiring diagram
  - Measuring range
  - Nominal range of use and measuring uncertainty
  - Nominal value
- ⇨ Press the **HELP** key in order to query online help.
- ⇨ If several pages of help are available for the respective measuring function, the **HELP** key must be pressed repeatedly.
- ⇨ Press the **ESC** key in order to exit online help.



• Measurement of  $U_{I\Delta N}$  and  $R_E$  with  $I_{I\Delta N}$ , without tripping of RCD.  
 •  $U_{I\Delta N}$ - and  $R_E$ -Measure:  
 Press **START**  
 • Subsequently, trip RCD:  
 Press **ESC**

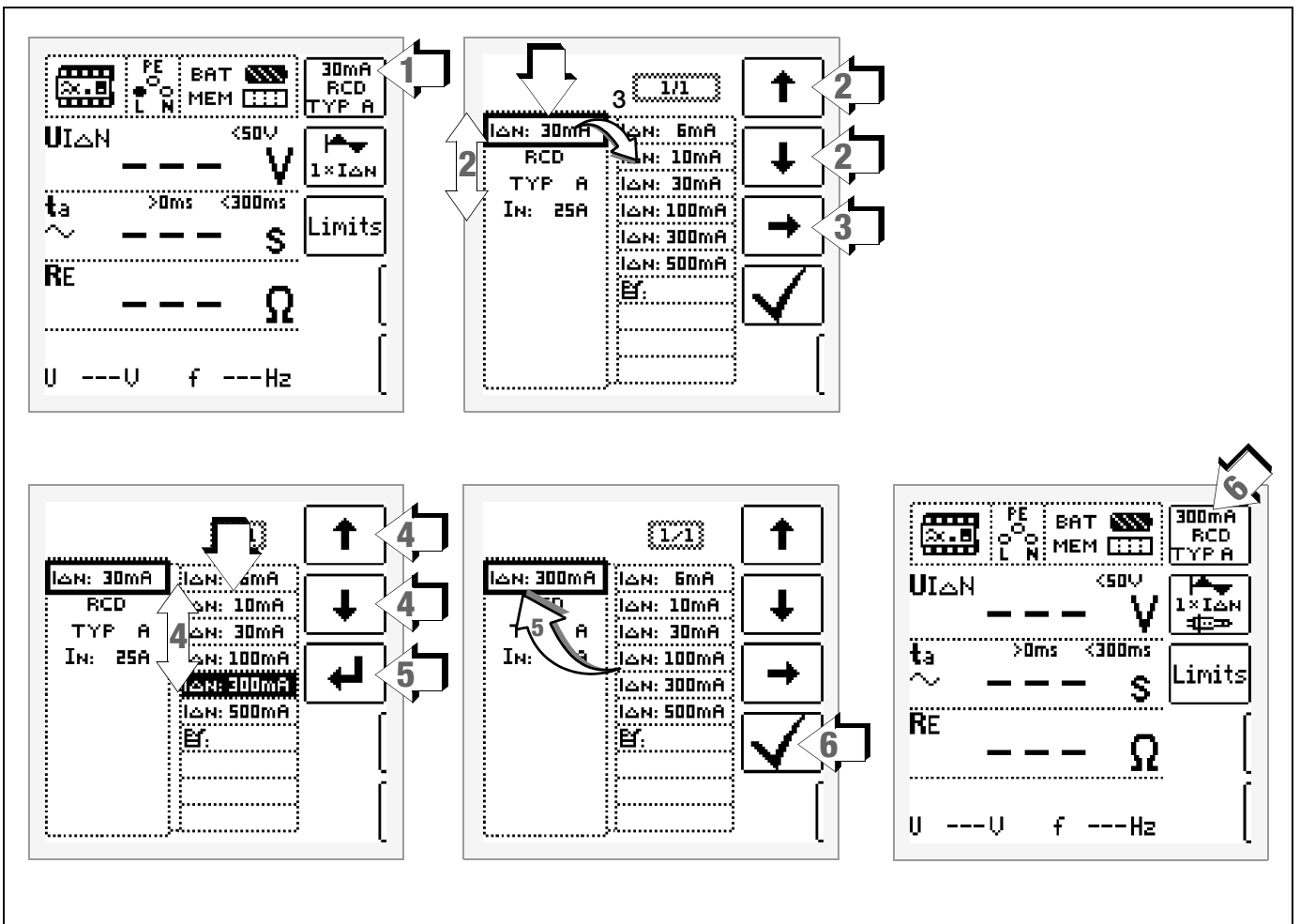

- 1 Access the submenu for setting the desired parameter.
- 2 Select a parameter using the ↑ or ↓ scroll key.
- 3 Switch to the setting menu for the selected parameter with the → scroll key.
- 4 Select a setting value using the ↑ or ↓ scroll key.
- 5 Acknowledge the setting value with the ↵ key. This value is transferred to the settings menu.
- 6 The setting value is not permanently accepted for the respective measurement until ✓ is pressed, after which the display is returned to the main menu. You can return to the main menu by pressing ESC instead of ✓, without accepting the newly selected value.

**Parameter Lock (plausibility check)**

Individually selected parameter settings are checked for plausibility before transfer to the measurement window.

If you select a parameter setting which doesn't make sense in combination with other parameter settings which have already been entered, it's not accepted. The previously selected parameter setting remains unchanged.

Remedy: select another parameter setting.

### 10.8 Freely Selectable Parameter Settings or Limit Values

In addition to fixed values, other values can be freely selected within predefined limits for certain parameters, if the symbol for the EDIT menu (3) appears at the end of the list of setting values.

#### Freely Selecting a Limit Value or Nominal Voltage

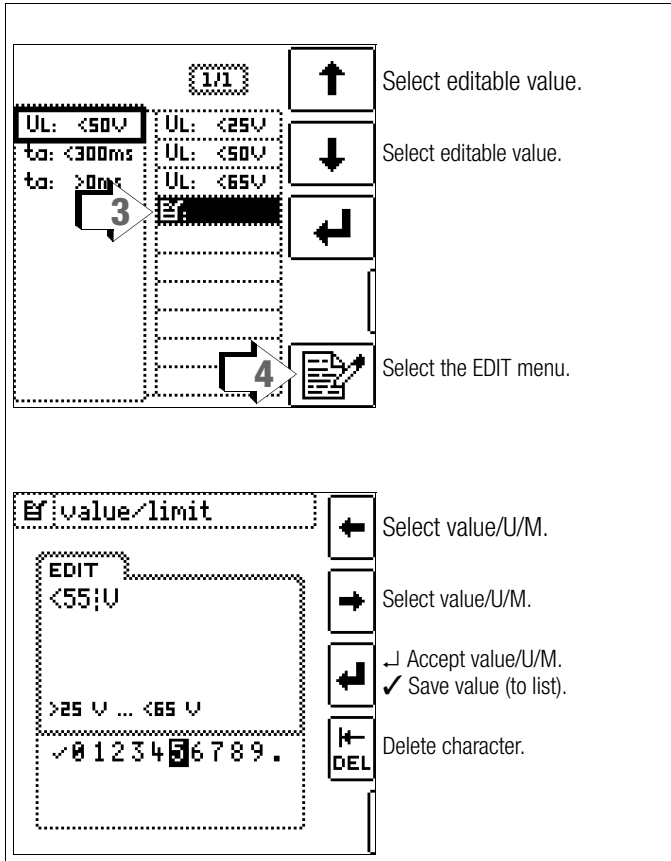

- 1 Open the submenu for setting the desired parameter (no figure (see section 10.7).
- 2 Select parameter ( $U_L$ ) using the  $\uparrow$  or  $\downarrow$  scroll key (no figure, see section 10.7).
- 3 Select a setting value with the help of the  $\text{EDIT}$  icon using the  $\uparrow$  or  $\downarrow$  scroll key.
- 4 Select the edit menu: Press the key with the  $\text{EDIT}$  icon.
- 5 Select the desired value or unit of measure with the LEFT or RIGHT scroll key. The value or unit of measure is accepted by pressing the  $\downarrow$  key. The value is acknowledged by selecting  $\checkmark$  and then pressing the  $\downarrow$  key. The new limit value or nominal value is added to the list.

#### Note

Observe the predefined limits for the new setting value. New, freely selected limit values or nominal values included in the parameters list can be deleted/edited at the PC with the help of ETC software. If the upper limit value is exceeded or if the lower limit value is fallen short of, this limit value is used (65 V respectively 25 V in the example).

### 10.9 2-Pole Measurement with Fast or Semiautomatic Polarity Reversal

Fast, semiautomatic polarity reversal is possible for the following measurements:

- Voltage measurement (U)
- Loop impedance measurement  $Z_{L-PE}$
- Internal line resistance measurement  $Z_{L-N}$
- Insulation resistance measurement – RINS

#### Fast Polarity Reversal

The polarity parameter is set to AUTO.

Fast and convenient switching amongst all polarity variants, or switching to the parameter settings submenu, is possible by pressing the  $I\Delta N$  key at the instrument.

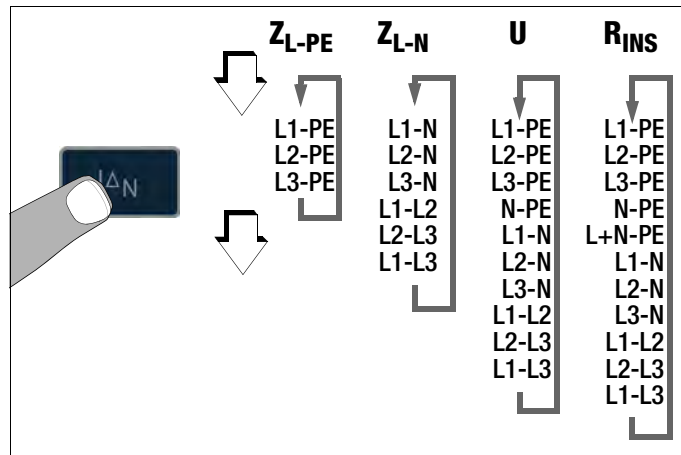
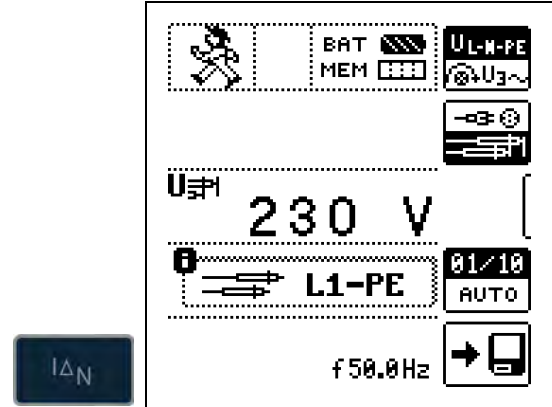

#### Semiautomatic Polarity Reversal in Memory Mode

The polarity parameter is set to AUTO.

If testing is to be conducted with all polarity variants, automatic polarity changing takes place at the end of each measurement after saving.

Polarity variants can be skipped by pressing the  $I\Delta N$  key at the instrument.

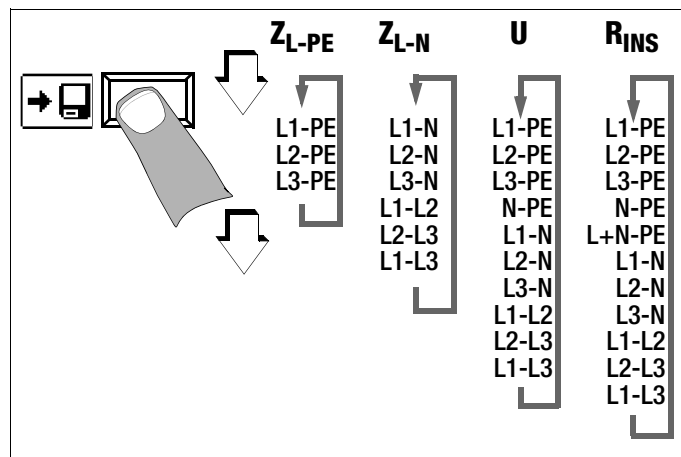



# 11 Measuring Voltage and Frequency

## Select Measuring Function

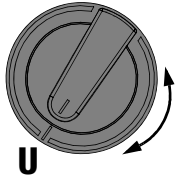

### Switch Back and Forth Between Single and 3-Phase Measurement



Press the softkey shown at the left in order to switch back and forth between single and 3-phase measurement. The selected phase measurement is displayed inversely (white on black).

## 11.1 Single-Phase Measurement

### Connection

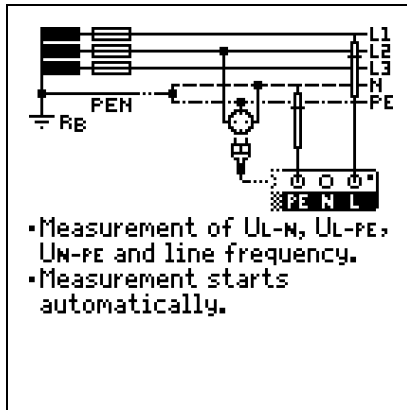

### 11.1.1 Voltage Between L and N ( $U_{L-N}$ ), L and PE ( $U_{L-PE}$ ) and N and PE ( $U_{N-PE}$ ) with Country-Specific Measuring Adapter, e.g. SCHUKO



Press the softkey shown at the left in order to switch back and forth between the country-specific measuring adapter, e.g. **PRO-Schuko measuring adapter** (Z503K), and 2-pole measurement with the **KS-PROFITEST INTRO** (Z503L). The selected connection type is displayed inversely (white on black).

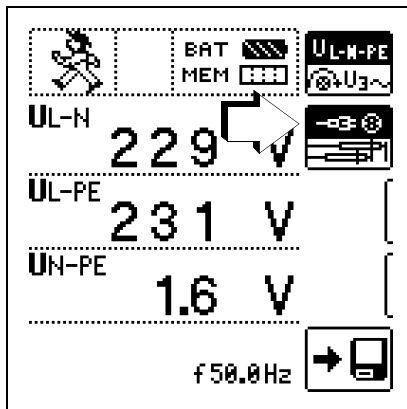

### 11.1.2 Voltage Between L – PE, N – PE and L – L with 2-Pole Connection



Press the softkey shown at the left in order to switch back and forth between the country-specific measuring adapter, e.g. **PRO-Schuko measuring adapter** (Z503K), and 2-pole measurement with the **KS-PROFITEST INTRO** (Z503L). The selected connection type is displayed inversely (white on black).

Refer to section 10.9 regarding 2-pole measurement with fast or semiautomatic polarity reversal.

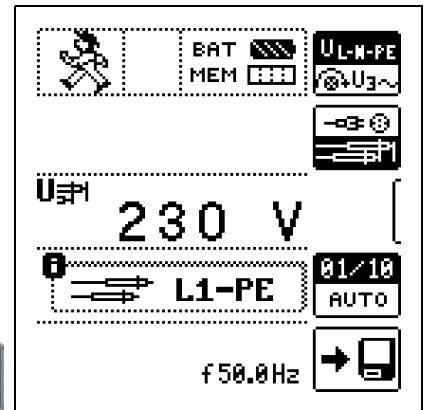
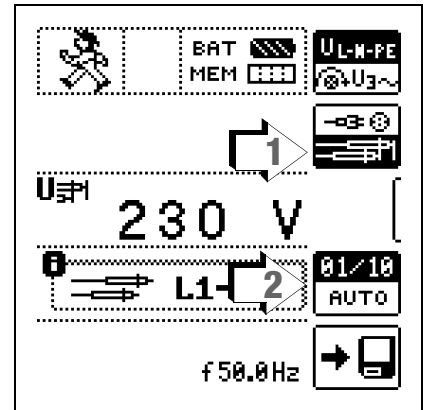

## 11.2 3-Phase Measurement (line-to-line voltage) and Phase Sequence

### Connection

The included measurement cables (Z503L) are required in order to connect the instrument.

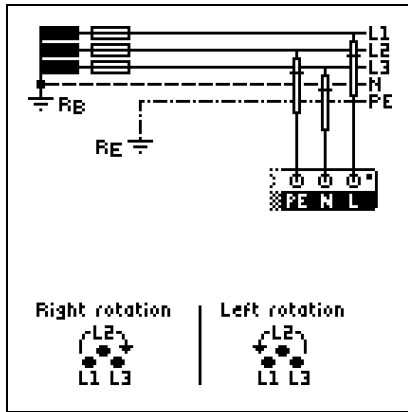

⇒ Press softkey U3~.

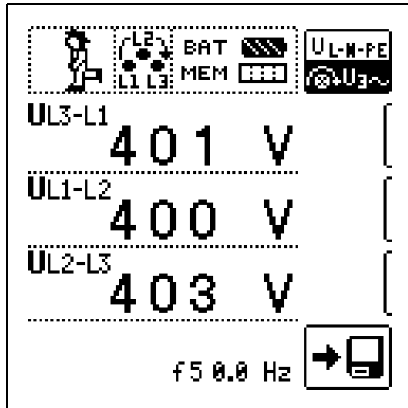

Clockwise phase sequence is required at all 3-phase electrical outlets.

- Measuring instrument connection is usually problematic with CEE outlets due to contact problems. Measurements can be executed quickly and reliably without contact problems with the help of the Z500A variable plug adapter set available from GMC.
- Connection for 3-wire measurement, plug L1-L2-L3 in clockwise direction beginning at PE socket

Direction of rotation is indicated by means of the following displays:

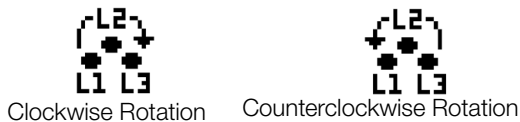

### Note

See section 6.2 regarding all indications for the mains connection test.

### Voltage Polarity

If the installation of single-pole switches to the neutral conductor is prohibited by the standards, voltage polarity must be tested in order to assure that all existing single-pole switches are installed to the phase conductors.

## 12 Testing RCDs

The testing of residual current devices (RCDs) includes:

- Visual inspection
- Testing
- Measurement

Use the test instrument for testing and measurement.

### Measuring Method

The following must be substantiated by generating a fault current downstream from the RCD:

- That the RCD is tripped no later than upon reaching its nominal fault current value
- That the continuously permissible touch voltage value  $U_L$  agreed upon for the respective system is not exceeded

This is achieved by means of:

- Touch voltage measurement  
10 measurements with full-waves and extrapolation of  $I_{\Delta N}$

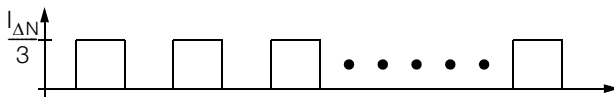

- Substantiation of tripping within 400 ms or 200 ms with  $I_{\Delta N}$

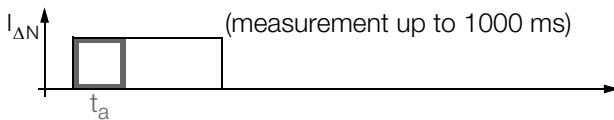

- Substantiation of tripping with rising residual current  
This value must be between 50% and 100% of  $I_{\Delta N}$  (usually about 70%).

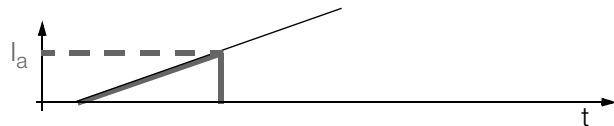

- No premature tripping with the test instrument, because testing is begun with 30% residual current (if no bias current occurs within the system).

### Test Standard

The following must be substantiated per DIN VDE 0100-600:2008 (IEC 60364-6):

- Touch voltage occurring at nominal residual current may not exceed the maximum permissible value for the system.
- Tripping of the RCCB must occur within 400 ms (1000 ms for selective RCDs) at nominal residual current.

### Important Notes



#### Note

Performance of RCD  $I_{F\Delta N}$  and RCD  $I_{\Delta N}$  measurements with DC test current is only recommended with a battery charge level of  $\geq 50\%$ .

- The PROFITEST INTRO permits simple measurements at all types of RCDs. Select RCD, SRCD, PRCD etc.
- Measurement must be executed at one point only per RCD (RCCB) within the connected electrical circuits. Low-resistance continuity must be substantiated for the protective conductor at all other connections within the electrical circuit ( $R_{LO}$  or  $U_B$ ).
- The measuring instruments often display 0.1 V touch voltage in TN systems due to low protective conductor resistance.
- Be aware of any bias currents within the system. These may cause RCD tripping during measurement of touch voltage  $U_B$ , or may result in erroneous displays for measurements with rising current:  
Display =  $I_{F\Delta N} - I_{bias\_current}$
- Selective RCDs identified with an **S** can be used as the sole means of protection for automatic shutdown if they adhere to the same shutdown conditions as non-selective RCDs (i.e.  $t_a < 400$  ms). This can be verified by measuring breaking time.
- Type B RCDs may not be connected in series with type A or F RCDs.



#### Note

##### Bias Magnetization

Suppression of RCD tripping by means of bias magnetization with direct current is only possible via a country-specific measuring adapter, e.g. **PRO-Schuko measuring adapter** (Z503K) or the **KS-PROFITEST INTRO** (Z503L) for 3-pole measurement.

RCD/FI Table	Residual Current Waveform	Correct RCD/RCCB Function			
		Type AC	Type A/F	Type B/B+	Type EV/MI
Alternating current	Suddenly occurring 	✓	✓	✓	✓
	Slowly rising 				
Pulsating Direct current	Suddenly occurring 		✓	✓	✓
	Slowly rising 				
Direct current				✓	✓
Direct current up to 6 mA					✓

## 12.1 Measuring Touch Voltage (with reference to nominal residual current) with 1/3 Nominal Residual Current and Tripping Test with Nominal Residual Current

### Select Measuring Function

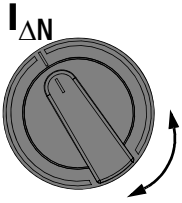

### Connection

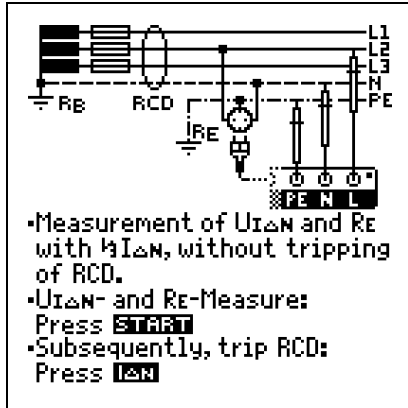

## 1) Measuring Touch Current Without Tripping the RCD

### Measuring Method

The instrument uses a measuring current of only 1/3 nominal residual current for the determination of touch voltage  $U_{I\Delta N}$  which occurs at nominal residual current. This prevents tripping of the RCCB.

This measuring method is especially advantageous, because touch voltage can be measured quickly and easily at any electrical outlet without tripping the RCCB.

The usual, complex measuring method involving testing for the proper functioning of the RCD at a given point, and subsequent substantiation that all other systems components requiring protection are reliably connected at low resistance values to the selected measuring point via the PE conductor, is made unnecessary.

### N-PE Reversal Test

Additional testing is conducted in order to determine whether or not N and PE are reversed. The pop-up window shown at the right appears in the event of reversal.

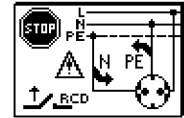

### Attention!

In order to prevent the loss of data in data processing systems, perform a data backup before starting the measurement and switch off all consumers.

### Set Parameters for $I_{\Delta N}$

**30mA RCD TYP A**  
 Nominal residual current: 10 ... 500 mA  
 Type 1: RCD, SRCD, PRCD ...  
 Type 2: AC, A/F, B/B+, B/B+\*, EV/MI  
 Nominal current: 6 ... 125 A  
 \* Type B/B+/EV/MI = AC/DC sensitive

**$I_{\Delta N}$ : 30mA**  
 RCD TYP A  
 In: 25A

Selection menu:  
 $I_{\Delta N}$ : 5mA, 10mA, 30mA, 100mA, 300mA, 500mA

**1 x  $I_{\Delta N}$**   
 Waveform:  
 Phase displacement: 0°/180°  
 Negative/positive half-wave  
 Positive direct current  
 X times tripping current:  
 1, 2, 5 ( $I_{\Delta N}$  max. 300 mA)

Selection menu:  
 0°:  $I_{\Delta N}$ , 180°  
 NEG: POS: POS: J/L

**Limits**  
 Touch voltage:  
 < 25 V, < 50 V, < 65 V  
 Time to trip:

Selection menu:  
 UL: <50V, <25V, <50V, <65V  
 ta: <300ms, >0ms

### Start Measurement



PE L N BAT MEM 30mA RCD TYP A  
 **$U_{I\Delta N}$**  <50V V  
 1 x  $I_{\Delta N}$   
**ta** >0ms <300ms S Limits  
**RE** Ω  
 U ---V f ---Hz

Amongst other values, touch voltage  $U_{I\Delta N}$  and calculated earthing resistance  $R_E$  appear at the display panel.



### Note

The measured earthing resistance value  $R_E$  is acquired with very little current. More accurate results can be obtained with the selector switch in the  $R_E$  position. The DC + function can be selected here for systems with RCCBs.

### Unintentional Tripping of the RCD due to Bias Current within the System

If bias currents should occur, they can be measured with the help of a current clamp. The RCCB may be tripped during the testing of touch voltage if extremely large bias currents are present within the system, or if a test current was selected which is too great for the RCCB.

After touch voltage has been measured, testing can be performed to determine whether or not the RCCB is tripped within the selected time limit values at nominal residual current.

### Unintentional Tripping of the RCD due to Leakage Current in the Measuring Circuit

Measurement of touch voltage with 30% nominal residual current does not normally trip an RCCB. However, the trip limit may be exceeded as a result of leakage current in the measuring circuit, e.g. due to interconnected consumers with EMC circuit, e.g. frequency converters or PCs.

## 2) Tripping Test after the Measurement of Touch Voltage

⇨ Press the  $I_{\Delta N}$  key

The tripping test only needs to be performed at one measuring point for each RCCB.

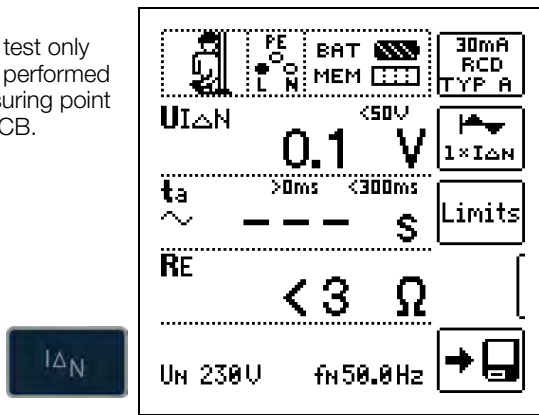

If the RCCB is not tripped at nominal residual current, the MAINS/NETZ LED blinks red (line voltage disconnected) and, amongst other values, time to trip  $t_a$  and earthing resistance  $R_E$  appear at the display panel.

If the RCCB is not tripped at nominal residual current, the LIMIT LED lights up red.

### Touch Voltage Too High

If touch voltage  $U_{I\Delta N}$ , which has been measured with  $\frac{1}{3}$  nominal residual current  $I_{\Delta N}$  and extrapolated to  $I_{\Delta N}$ , is  $> 50$  V ( $> 25$  V), the LED LIMIT lights up red.

If touch voltage  $U_{I\Delta N}$  exceeds 50 V (25 V) during the measuring procedure, safety shut-down occurs.



#### Note

**Safety shutdown:** At up to 70 V, safety shutdown is triggered within 3 s in accordance with IEC 61010.

Touch voltages of up to 70 V are displayed. If touch voltage is greater than 70 V,  $U_{I\Delta N} > 70$  V is displayed.

### Limit Values for Permissible, Continuous Touch Voltage

The limit for permissible, continuous touch voltage is equal to  $U_L = 50$  V for alternating voltages (international agreement). Lower values have been established for special applications (e.g. medical applications:  $U_L = 25$  V).



#### Attention!

If touch voltage is too high, or if the RCCB is not tripped, the system must be repaired (e.g. earthing resistance is too high, defective RCCB etc.)!

### 3-Phase Connections

For proper RCD testing at three-phase connections, the tripping test must be conducted for one of the three phase conductors (L1, L2 and L3).

### Inductive Power Consumers

Voltage peaks may occur within the measuring circuit if inductive consumers are shut down during an RCCB tripping test. If this is the case, the test instrument might not display any measured value (---). If this message appears, switch all consumers off before performing the tripping test. In extreme cases, one of the fuses in the test instrument may blow, and/or the test instrument may be damaged.

## 12.2 Special Tests for Systems and RCCDs

### 12.2.1 Testing Systems and RCCBs with Rising Residual Current (AC) for Type AC, A/F, B/B+ and EV, MI RCCDs

#### Measuring Method

The instrument generates a continuously rising residual current of  $(0.3 \dots 1.3) \times I_{\Delta N}$  within the system for the testing of RCCDs. The instrument stores the touch voltage and tripping current values which were measured at the moment tripping of the RCCB occurred, and displays them.

One of touch voltage limit values,  $U_L = 25$  V or  $U_L = 50/65$  V, can be selected for measurement with rising residual current.

#### Select Measuring Function

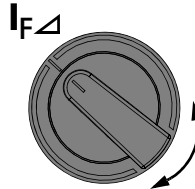

#### Connection

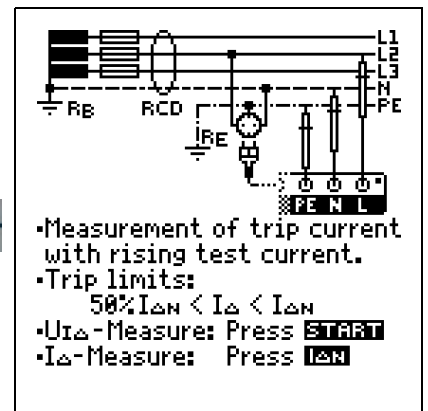

#### Set Parameters for $I_{F\Delta}$

Nominal residual current: 10 ... 500 mA  
 Type 1: RCD, SRCD, PRCD ...  
 Type 2: AC, A/F, B/B+, EV/MI  
 Nominal current: 6 ... 125 A  
 \* Type B/B+/EV/MI = AC/DC sensitive

Waveform:  
 Neg. half-wave  
 Pos. half-wave  
 Positive direct current

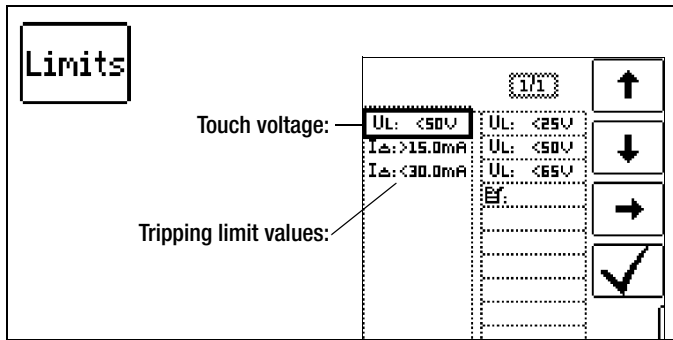

### Start Measurement

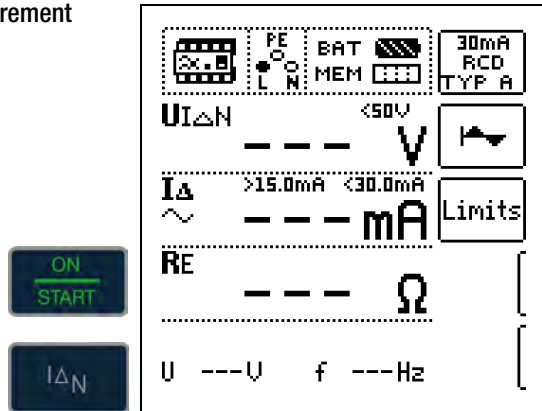

### Measuring Sequence

After the measuring sequence has been started, the test current generated by the instrument is continuously increased starting at 0.3 times nominal residual current, until the RCCB is tripped. This can be observed by viewing gradual filling of the triangle at I<sub>Δ</sub>. If touch voltage reaches the selected limit value (U<sub>L</sub> = 65 V, 50 V or 25 V) before the RCCB is tripped, safety shutdown occurs. The **LIMIT LED** lights up red.

#### Note

**Safety shutdown:** At up to 70 V, safety shutdown is triggered within 3 s in accordance with IEC 61010.

If the RCCB is not tripped before the rising current reaches nominal residual current I<sub>ΔN</sub>, the **LIMIT LED** lights up red.



#### Attention!

If bias current is present within the system during measurement, it's superimposed onto the residual current which is generated by the instrument and influences measured values for touch voltage and tripping current. See also section 12.1.

### Evaluation

According to DIN VDE 0100-600 (IEC 60364-6), rising residual current must, however, be used for measurements for the evaluation of RCDs, and touch voltage at nominal residual current I<sub>ΔN</sub> must be calculated from the measured values.

The faster, more simple measuring method should thus be taken advantage of (see section 12.1).

### 12.2.2 Testing Systems and RCCBs with Rising Residual Current (AC) for Type B/B+ and EV, MI RCDs

In accordance with VDE 0413-6, it must be substantiated that, with smooth direct current, residual operating current is no more than twice the value of rated residual current I<sub>ΔN</sub>. A continuously rising direct current, beginning with 0.2 times rated residual current I<sub>ΔN</sub>, must be applied to this end. If current rise is linear, rising current may not exceed twice the value of I<sub>ΔN</sub> within a period of 5 seconds.

Testing with smoothed direct current must be possible in both test current directions.

### 12.2.3 Testing RCCBS with 5 × I<sub>ΔN</sub>

Measurement of time to trip is performed here with 5 times nominal residual current.



#### Note

Measurements performed with 5 times nominal fault current are required for testing type **S** and G RCCBs in the manufacturing process. They're used for personal safety as well.

Measurement can be started with the positive half-wave at "0°" or with the negative half-wave at "180°".

Both measurements must nevertheless be performed. The longer of the two tripping times is decisive regarding the condition of the tested RCCB. Both values must be less than 40 ms.

### Select Measuring Function

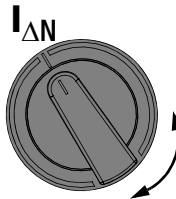

### Set Parameter – Start with Positive or Negative Half-Wave

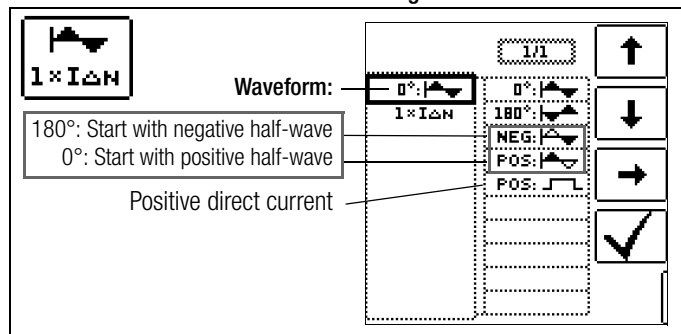

### Set Parameter – 5 Times Nominal Current

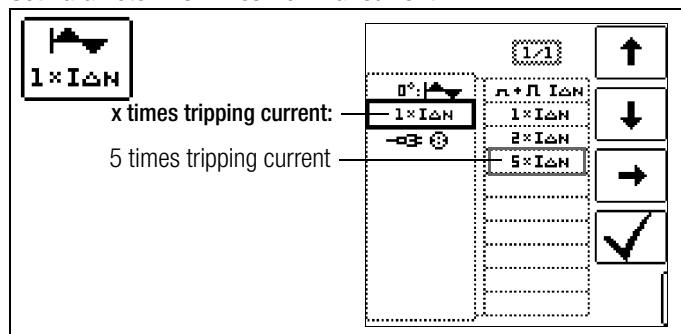

#### Note

The following restrictions apply to the selection of tripping current multiples relative to nominal current:  
500 mA: 1 × I<sub>ΔN</sub>, 2 × I<sub>ΔN</sub>

### Start Measurement

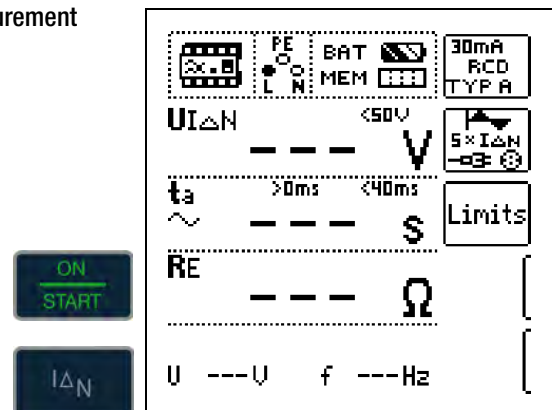

## 12.2.4 Testing of RCCBs which are Suitable for Pulsating DC Residual Current

In this case, RCCBs can be tested with either positive or negative half-waves. The standard calls for tripping at 1.4 times nominal current.

### Select Measuring Function

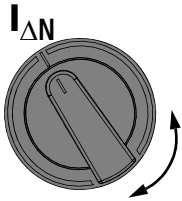

### Set Parameter – Positive or Negative Half-Wave

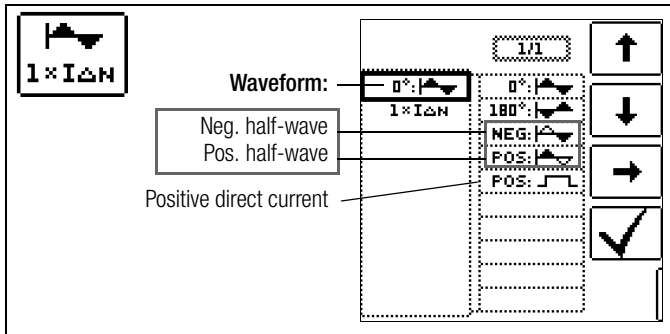

### Set Parameter – Test With and Without “No-Trip Test”

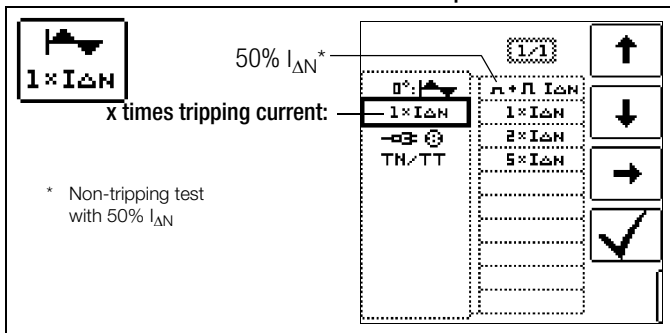

### Non-Tripping Test

If, during the non-tripping test which lasts for 1 second, the RCD trips too early at 50%  $I_{\Delta N}$ , i.e. before the actual tripping test starts, the pop-up window shown at the right appears.

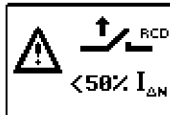

### Note

The following restriction applies to the selection of tripping current multiples relative to nominal current: double and five-fold nominal current is not possible in this case.

### Note

According to DIN EN 50178 (VDE 160), only type B RCCBs (AC-DC sensitive) can be used for equipment with > 4 kVA, which is capable of generating smooth DC residual current (e.g. frequency converters). Tests with pulsating DC fault current only are not suitable for these RCCBs. Testing must also be conducted with smooth DC residual current in this case.

### Note

Measurement is performed with positive and negative half-waves for testing RCCBs during manufacturing. If a circuit is charged with pulsating direct current, the function of the RCCB can be executed with this test in order to assure that the RCCB is not saturated by the pulsating direct current so that it no longer trips.

## 12.3 Testing of Special RCDs

### 12.3.1 Systems with Type RCD-S (selective)

Selective RCDs are used in systems which include two series connected RCCBs that are not tripped simultaneously in the event of a fault. These selective RCDs demonstrate delayed response characteristics and are identified with the symbol.

### Measuring Method

The same measuring method is used as for standard RCCBs (see sections 12.1 on page 36 and 12.2.1 on page 37).

If selective RCDs are used, earthing resistance may not exceed half of the value for standard RCCBs.

For this reason, the instrument displays twice the measured value for touch voltage.

### Select Measuring Function

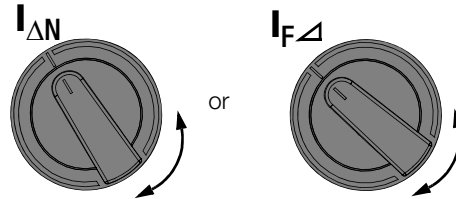

### Set Parameter – Selective

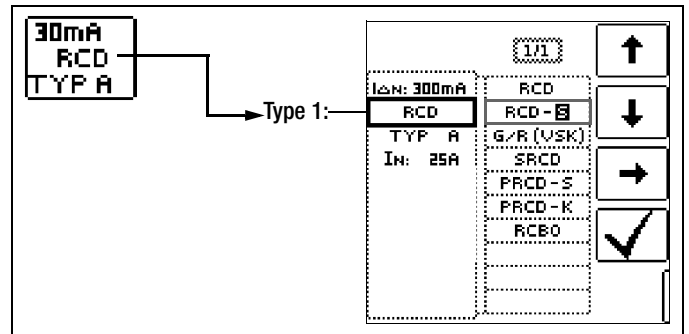

### Start Measurement

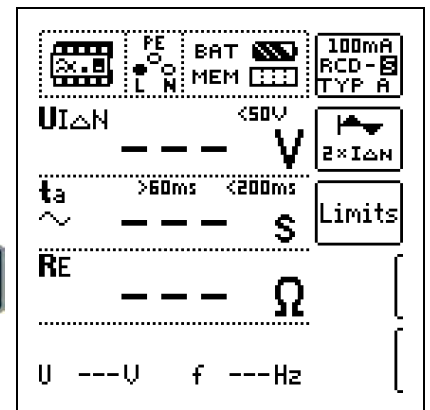

## Tripping Test

- Press the  $I_{\Delta N}$  key. The RCCB is tripped. Blinking bars appear at the display panel, after which time to trip  $t_A$  and earthing resistance  $R_E$  are displayed.

The tripping test only needs to be performed at one measuring point for each RCCB.

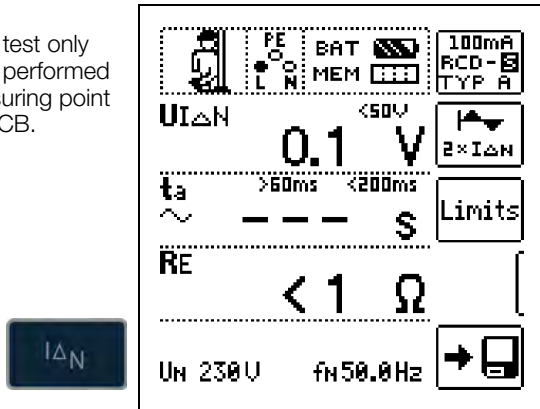

### Note

Selective RCDs demonstrate delayed response characteristics. Tripping performance is briefly influenced (up to 30 s) due to pre-loading during measurement of touch voltage. In order to eliminate pre-charging caused by the measurement of touch voltage, a waiting period must be observed prior to the tripping test. After the measuring sequence has been started (tripping test), blinking bars are displayed for approximately 30 seconds. Tripping times of up to 1000 ms are permissible. The tripping test is executed immediately after once again pressing the  $I_{\Delta N}$  key.

## 12.3.2 PRCDs with Non-Linear Type PRCD-K Elements

The PRCD-K is a portable RCD with electronic residual current evaluation laid out as an inline device which switches all poles (L, N and PE). Undervoltage tripping and protective conductor monitoring are additionally integrated into the PRCD-K.

The PRCD-K is equipped with undervoltage tripping, for which reason it has to be operated with line voltage, and measurements may only be performed in the on state (PRCD-K switches all poles).

### Terminology (from DIN VDE 0661)

Portable protective devices are circuit breakers which can be connected between power consuming devices and permanently installed electrical outlets by means of standardized plug-and-socket devices.

A reusable, portable protective device is a protective device which is designed such that it can be connected to movable cables.

Please be aware that a non-linear element is usually integrated into PRCDs, which leads to immediate exceeding of the greatest allowable touch voltage during  $U_{I\Delta}$  measurements ( $U_{I\Delta}$  greater than 50 V).

PRCDs which do not include a non-linear element in the protective conductor must be tested in accordance with section 12.3.3 on page 41.

### Objective (from DIN VDE 0661)

Portable residual current devices (PRCDs) serve to protect persons and property. They allow for the attainment of increased levels of protection as provided by protective measures utilized in electrical systems for the prevention of electrical shock as defined in DIN VDE 0100-410. They must be designed such that they can be installed by means of a plug attached directly to the protective device, or by means of a plug with a short cable.

## Measuring Method

The following can be measured, depending upon the measuring method:

- Time to trip  $t_A$ : tripping test with nominal residual current  $I_{\Delta N}$  (The PRCD-K must be tripped at 50% nominal current.)
- Tripping current  $I_{\Delta}$  for testing with rising residual current  $I_{F\Delta}$

### Select Measuring Function

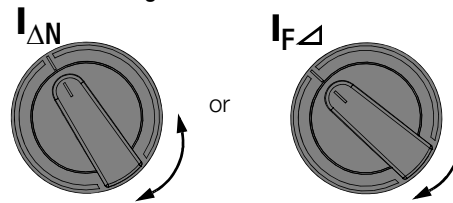

### Connection

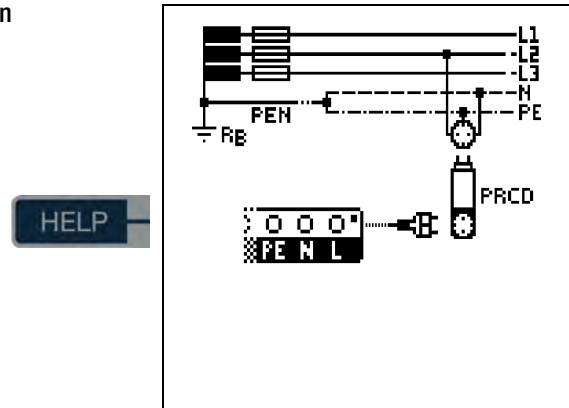

### Set Parameter – PRCD with Non-Linear Elements

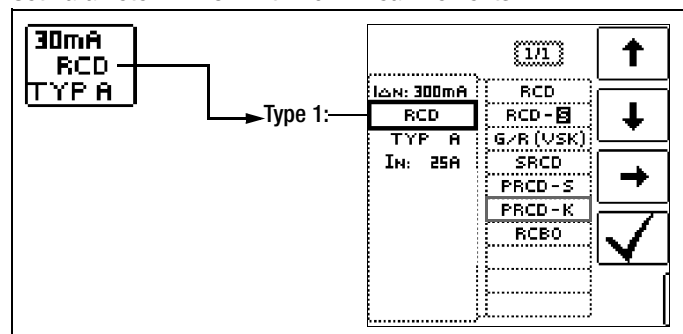

### Start Measurement

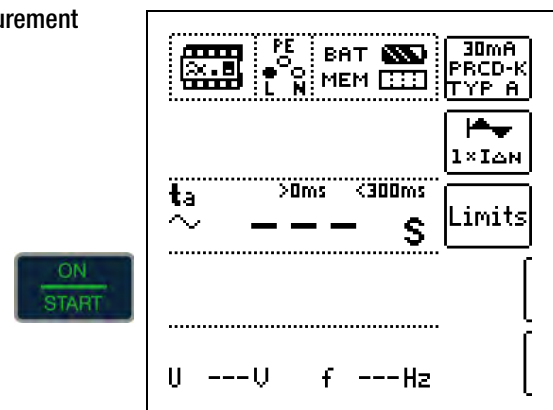



### 12.3.3 SRCD, PRCD-S (SCHUKOMAT, SIDOS or comparable)

RCCBs from the SCHUKOMAT SIDOS series, as well as others which are of identical electrical design, must be tested after selecting the corresponding parameter.

Monitoring of the PE conductor is performed for RCDs of this type. The PE conductor is monitored by the summation current transformer. If residual current flows from L to PE, tripping current is cut in half, i.e. the RCCB must be tripped at 50% nominal residual current  $I_{\Delta N}$ .

Whether or not PRCDs and selective RCDs are of like design can be tested by means of touch voltage  $U_{I\Delta N}$  measurement. If a touch voltage  $U_{I\Delta N}$  of greater than 70 V is measured at the PRCD of an otherwise error-free system, the PRCD more than likely contains a non-linear element.

#### PRCD-S

The PRCD-S (portable residual current device – safety) is a special, portable, protective device with protective conductor detection or protective conductor monitoring. The device serves to protect persons from electrical accidents in the low-voltage range (130 to 1000 V). The PRCD-S must be suitable for commercial use, and is installed like an extension cable between an electrical consumer – as a rule an electrical tool – and the electrical outlet.

#### Select Measuring Function

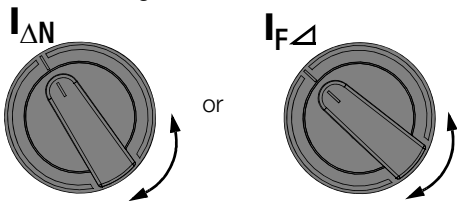

#### Set Parameter – SRCD / PRCD

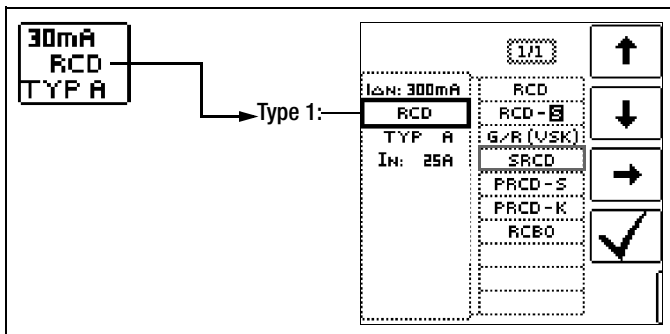

#### Start Measurement

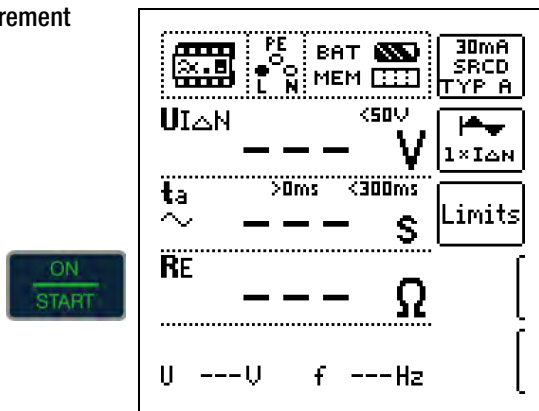

### 12.3.4 Type G or R RCCB

In addition to standard RCCBs and selective RCDs, the special characteristics of the type G RCCB can also be tested with the test instrument.

The type G RCCB is an Austrian specialty which complies with device standard ÖVE/ÖNORM E 8601. Erroneous tripping is minimized thanks to its greater current carrying capacity and short-term delay.

#### Select Measuring Function

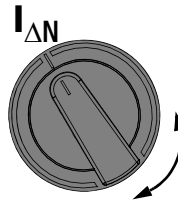

#### Set Parameter – Type G/R (VSK)

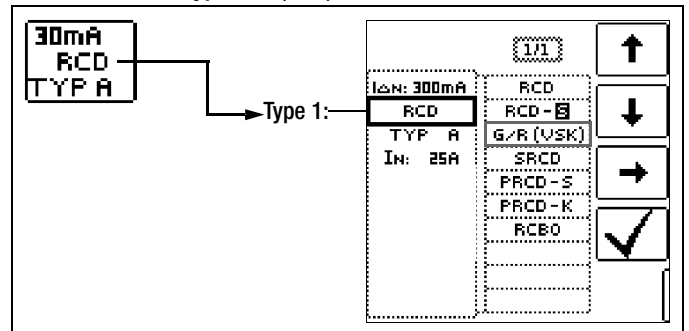

Touch voltage and time to trip can be measured in the G/R-RCD switch position.



#### Note

It must be observed that time to trip for type G RCCBs may be as long as 1000 ms when measurement is made at nominal residual current. Set the limit value correspondingly.

- Then select  $5 \times I_{\Delta N}$  in the menu (this is selected automatically for the G/R setting) and repeat the tripping test beginning with the positive half-wave at  $0^\circ$  and the negative half-wave at  $180^\circ$ . The longer of the two tripping times is decisive regarding the condition of the tested RCCB.

#### Set Parameter – Start with Positive or Negative Half-Wave

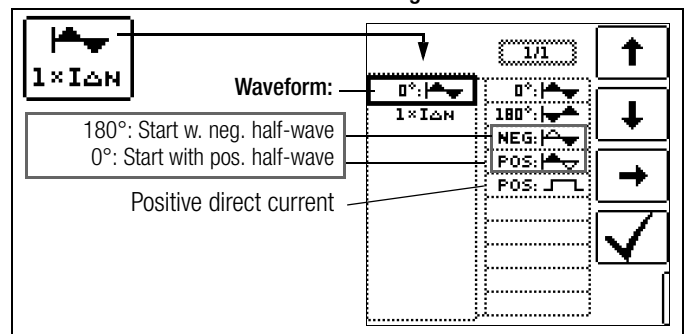

## Set Parameter – 5 Times Nominal Current

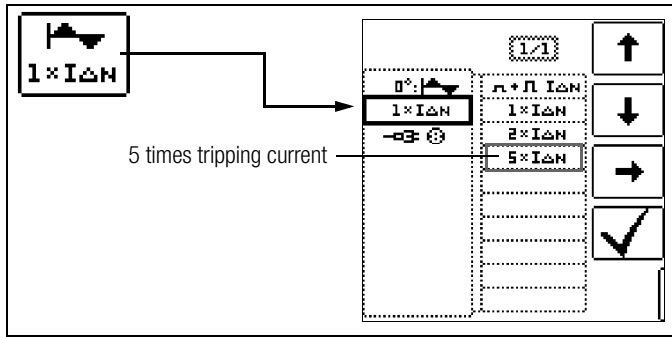

### Note

The following restrictions apply to the selection of tripping current multiples relative to nominal current:  
500 mA:  $1 \times I_{\Delta N}$ ,  $2 \times I_{\Delta N}$

## Start Measurement

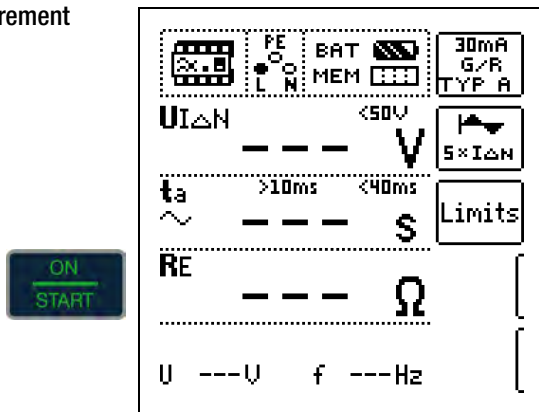

In both cases tripping time must be between 10 ms (minimum delay time for type G RCCBs) and 40 ms.

Type G RCCBs with other nominal residual current values must be tested with the corresponding parameter setting under menu item  $I_{\Delta N}$ . In this case as well, the limit value must be appropriately adjusted.

### Note

The RCD **S** parameter setting for selective RCCBs is not suitable for type G RCCBs.

## 12.4 Testing Residual Current Circuit Breakers in TN-S Systems

### Connection

RCCBs can only be used in TN-S systems. An RCCB would not work in a TN-C system because PE is directly connected to the neutral conductor in the outlet (it doesn't bypass the RCCB). This means that residual current would be returned via the RCCB and would not generate any residual current, which is required in order to trip the RCCB.

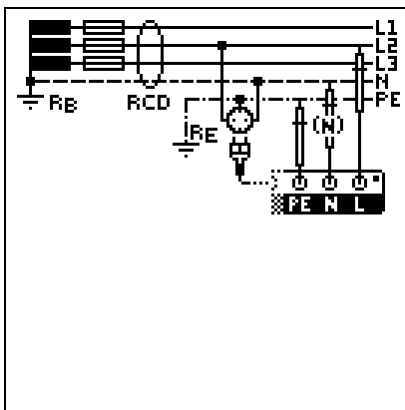

As a rule, the display for touch voltage is also 0.1 V, because the nominal residual current of 30 mA together with minimal loop resistance result in a very small voltage value:

$$U_{I\Delta N} = R_E \cdot I_{\Delta N} = 1 \Omega \cdot 30 \text{ mA} = 30 \text{ mV} = 0,03 \text{ V}$$

## 13 Testing of Breaking Requirements for Overcurrent Protective Devices, Measurement of Loop Impedance and Determination of Short-Circuit Current ( $Z_{L-PE}$ and $I_{SC}$ functions)

Testing of overcurrent protective devices includes visual inspection and measurement. Use the PROFITEST INTRO to perform measurements.

### Measuring Method

Loop impedance  $Z_{L-PE}$  is measured and short-circuit current  $I_{SC}$  is ascertained in order to determine if the breaking requirements for protective devices have been fulfilled.

Loop impedance is the resistance within the current loop (utility station – phase conductor – protective conductor) when a short-circuit to an exposed conductive part occurs (conductive connection between phase conductor and protective conductor). Short-circuit current magnitude is determined by the loop impedance value. Short-circuit current  $I_{SC}$  may not fall below a predetermined value set forth by DIN VDE 0100, so that reliable breaking of the protective device (fuse, automatic circuit breaker) is assured.

The measured loop impedance value must therefore be less than the maximum permissible value.

Tables containing permissible display values for loop impedance and minimum short-circuit current display values for ampere ratings for various fuses and circuit breakers can be found in the help texts and in section 23 beginning on page 59. Maximum device error in accordance with VDE 0413 has been taken into consideration in these tables. See also section 13.2.

In order to measure loop impedance  $Z_{L-PE}$ , the instrument uses a test current of 3.7 to 7 A (60 to 550 V) depending on line voltage and line frequency. At 16 Hz, the test has a duration of no more than 1200 ms.

**If dangerous touch voltage occurs during measurement (> 50 V), safety shut-down occurs.**

The test instrument calculates short-circuit current  $I_{SC}$  based on measured loop impedance  $Z_{L-PE}$  and line voltage. Short-circuit current calculation is made with reference to nominal line voltage for line voltages which lie within the nominal ranges for 120, 230 and 400 V systems. If line voltage does not lie within these nominal ranges, the instrument calculates short-circuit current  $I_{SC}$  based upon prevailing line voltage and measured loop impedance  $Z_{L-PE}$ .

### Measuring Method with Suppression of RCD Tripping

The PROFITEST INTRO provides users with the opportunity of measuring loop impedance within systems which are equipped with RCCBs.

The test instrument generates a direct current to this end, which saturates the RCCB's magnetic circuit.

The test instrument then superimposes a measuring current which only demonstrates half-waves of like polarity. The RCCB is no longer capable of detecting this measuring current and is consequently not tripped during measurement.

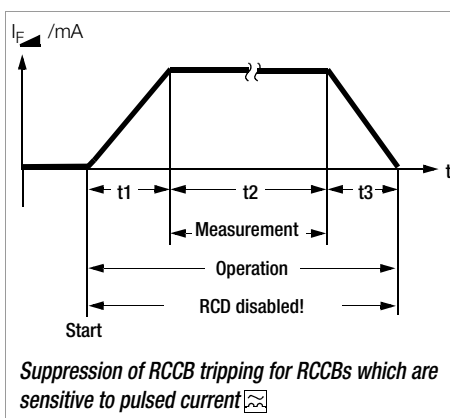

### Select Measuring Function

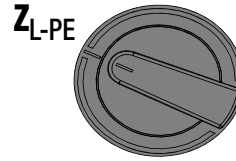

#### Note

Performance of the ZLOOP DC+ (DC-H) measurement with DC test current is only recommended with a battery charge level of  $\geq 50\%$ .

### Connection: Schuko/3-pole

(country specific)

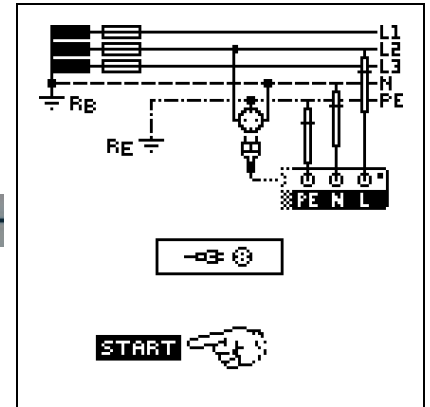

### Connection: 2-pole

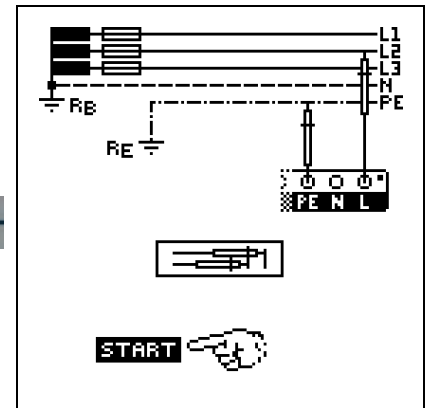

#### Note

Loop impedance should be measured for each electrical circuit at the farthest point, in order to ascertain maximum loop impedance for the system.

#### Note

##### Bias Magnetization

Suppression of RCD tripping by means of bias magnetization with direct current is only possible via a country-specific measuring adapter, e.g. PRO-Schuko measuring adapter (Z503K) or the KS-PROFITEST INTRO (Z503L) for 3-pole measurement (neutral conductor required).

#### Note

Observe national regulations, e.g. the necessity of conducting measurements without regard for RCCBs in Austria.

### 3-Phase Connections

Measurement of loop impedance to earth must be performed at all three phase conductors (L1, L2, and L3) for the testing of over-current protective devices at three phase outlets.

#### 13.1 Measurements with Suppression of RCD Tripping

##### 13.1.1 Measurement with Positive Half-Waves

Measurement by means of half-waves plus direct current makes it possible to measure loop impedance in systems which are equipped with RCCBs. In the case of DC measurement with half-waves, selection can be made between two variants:

- DC-L:** Reduced bias current but faster measurement as a result
- DC-H:** Higher bias current providing more reliability with regard to non-tripping of the RCD

#### Select Measuring Function

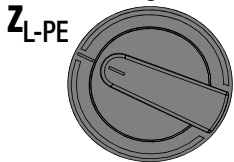

**Measurement with country-specific measuring adapter (e.g. Schuko)**

L1-PE

2-pole measurement

L1-PE

1/1

AUTO

L1-PE

L1-PE

L2-PE

L3-PE

AUTO

↑

↓

→

✓

**Note**  
Selecting the test probe, as well as Lx-PE reference or AUTO, is only relevant with regard to report generation.

**Polarity Selection**

**Semiautomatic Measurement**

See also section 10.9 regarding the AUTO parameter.

#### Set Parameters

IN 16A  
E/E(L)  
1.5 mm<sup>2</sup>

Nominal current: 2 A ... 160 A, 9999 A

Tripping characteristics: A, B/L, C/G, D, E, H, K, GL/GG & factor

Diameter\*: 1.5 to 70 mm<sup>2</sup>

Cable type\*: NY... - H07...

Number of wires\*: 1 ... 10-wire

1/2

IN: 16A

5 x IN(E/L)

2.0A

3.0A

4.0A

6.0A

8.0A

10A

13A

16A

20A

25A

1/1

IN: 16A

2.0A

3.0A

4.0A

6.0A

8.0A

10A

13A

16A

20A

25A

↑

↓

→

✓

\* Parameters which are only used for report generation and do not influence the measurement

UL <50V  
DC

Touch voltage: UL <50V

Waveform: DC-H+

Sinusoidal

15 mA sinusoidal

DC-L and positive half-wave

DC-H and positive half-wave

1/1

UL <50V

0°

15mA

BC-L+

BC-H+

1/1

UL <50V

0°

15mA

BC-L+

BC-H+

↑

↓

→

✓

- Sinusoidal (full-wave)** Setting for circuit without RCD
- 15 mA sinusoidal** Setting for motor protection switch only with small nominal current
- DC + half-wave** Setting for circuit with RCD

## Measurement Cable Compensation

The resistance of the connected measurement cable or the country-specific measuring adapter must be compensated, i.e. subtracted from the measurement result as an offset, for each loop resistance measurement. Proceed as described in section 8 under "OFFSET RL-PE / RN-PE / RL-N" on page 23 in order to determine offset values  $RLPE-OFFSET$  and  $RNPE-OFFSET$ .

### Start Measurement

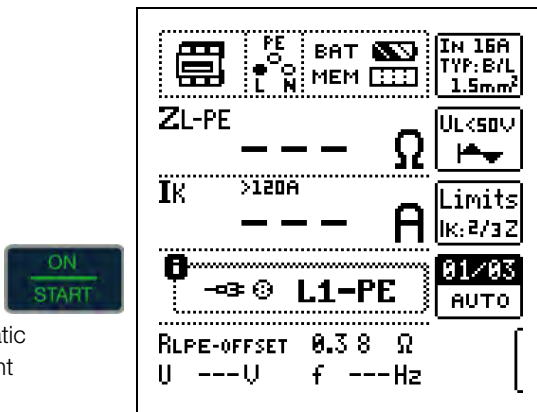
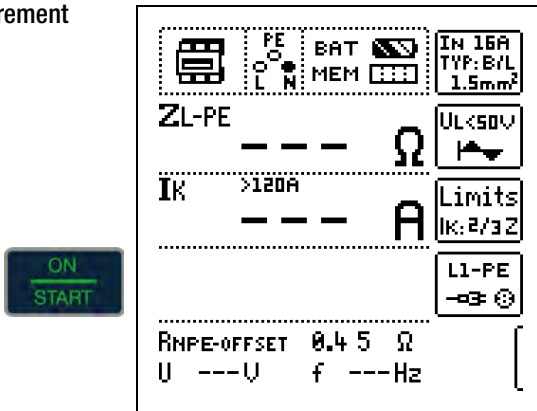

Semiautomatic Measurement

### 13.2 Evaluation of Measured Values

The maximum allowable loop impedance  $Z_{L-PE}$  which may be displayed after allowance has been made for maximum operating measurement error (under normal measuring conditions) can be determined with the help of Table 1 on page 59. Intermediate values can be interpolated.

The maximum permissible nominal current for the protective device (fuse or circuit breaker) for a line voltage of 230 V after allowance has been made for maximum measuring error can be determined with the help of Table 5 on page 60 based on measured short-circuit current (corresponds to DIN VDE 0100-600 / IEC 60364-6).

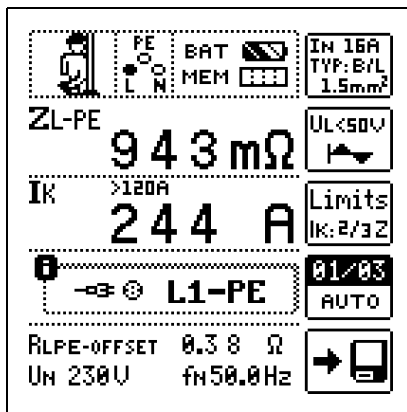

### Special Case: Suppressing Display of the Limit Value

The limit value cannot be ascertained. The inspector is prompted to evaluate the measured values himself, and to acknowledge or reject them with the help of the softkeys.

Measurement passed:  
✓ key

Measurement failed:  
X key

The measured value can only be saved after it has been evaluated.

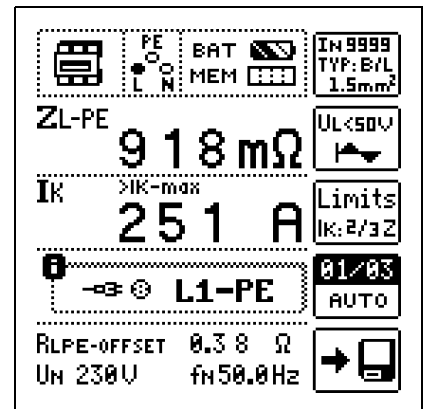
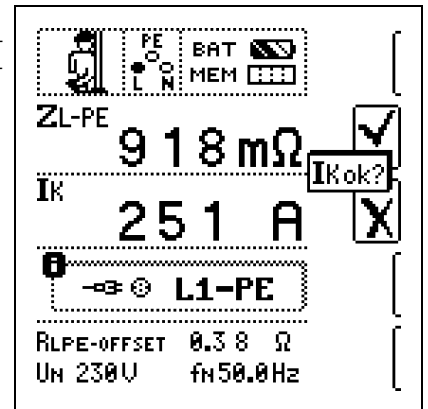

### 13.3 Settings for Calculating Short-Circuit Current - Parameter $I_{SC}$

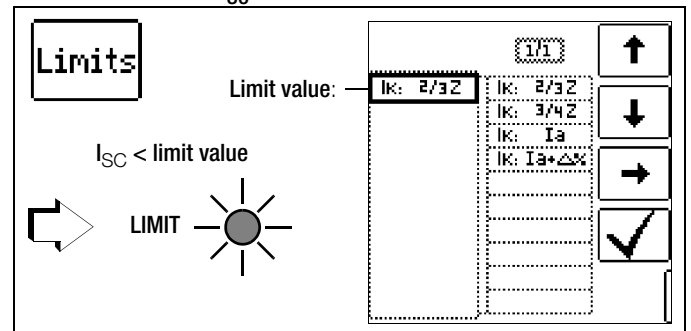

Short-circuit current  $I_{SC}$  is used to test shutdown by means of an overcurrent protective device. In order for an overcurrent protective device to be tripped on time, short-circuit current  $I_{SC}$  must be greater than tripping current  $I_a$  (see table 6 in section 23.1). The variants which can be selected with the "Limits" key have the following meanings:

- $I_{SC}: I_a$  The measured value displayed for  $Z_{L-PE}$  is used without any correction to calculate  $I_{SC}$ .
- $I_{SC}: I_a + \Delta\%$  The measured value displayed for  $Z_{L-PE}$  is corrected by an amount equal to the test instrument's measuring uncertainty in order to calculate  $I_{SC}$ .
- $I_{SC}: \frac{2}{3} Z$  In order to calculate  $I_{SC}$ , the measured value displayed for  $Z_{L-PE}$  is corrected by an amount corresponding to all possible deviations (these are defined in detail by VDE 0100-600 (IEC 60364-6) as  $Z_{s(m)} \leq \frac{2}{3} \times U_0 / I_a$ ).
- $I_{SC}: \frac{3}{4} Z$   $Z_{s(m)} \leq \frac{3}{4} \times U_0 / I_a$

$I_{SC}$  Short-circuit current calculated by the instrument (at nominal voltage)  
 $Z$  Fault loop impedance  
 $I_a$  Tripping current (see data sheet for circuit breakers / fuses)  
 $\Delta\%$  Test instrument intrinsic error

Special case:  $I_{SC} > I_{SCmax}$ , see page 46.

See page 47 in order to display the fuse table using the **HELP** key.

## 14 Measuring Supply Impedance ( $Z_{L-N}$ function)

### Measuring Method (internal line resistance measurement)

Supply impedance  $Z_{L-N}$  is measured by means of the same method used for loop impedance  $Z_{L-PE}$  (see section 13 on page 43). However, the current loop is completed via neutral conductor N rather than protective conductor PE as is the case with loop impedance measurement.

### Select Measuring Function

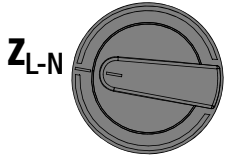

### Schuko Connection (country specific)

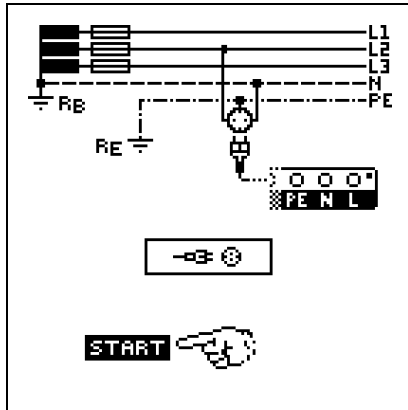

### Connection: 2-pole

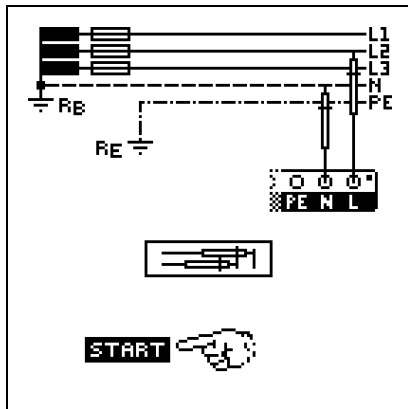

### Set Parameters

**IN 16A**  
E-PE(L)  
1.5 mm<sup>2</sup>

Nominal current:  
2 A ... 160 A, 9999 A

Tripping characteristics:  
A, B/L, C/G, D, E, H, K, GL/GG & factor

Diameters: 1.5 ... 70 mm<sup>2</sup>

Cable type: NY..., A07...

Number of wires: 1 ... 10-wire

IN: 16A	IN: 20A
5 x IN(B/L)	IN: 30A
Ø: 1.5 mm <sup>2</sup>	IN: 40A
NYM-J	IN: 60A
3-ADRIG	IN: 80A
	IN: 10A
	IN: 13A
	IN: 16A
	IN: 20A
	IN: 25A

Press the softkey shown at the left in order to switch back and forth between the country-specific measuring adapter, e.g. PRO-Schuko measuring adapter (Z503K) / 3-pole measurement and the KS-PROFIT-EST INTRO (Z503L) for 2-pole measurement. The selected connection type is displayed inversely (white on black).

01/03  
AUTO

Polarity Selection

Semiautomatic Measurement

See also section 10.9 regarding the AUTO parameter. L-PE references are not possible here. The neutral L-N reference is not offered during automatic sequencing to the right of the auto entry!

↑
↓
→
✓

### Settings for Calculating Short-Circuit Current – Parameter $I_{SC}$

Limits  $I_{SC}$

Limit value: IK: 2/3Z

$I_{SC} < \text{limit value}$

LIMIT

↑
↓
→
✓

Short-circuit current  $I_{SC}$  is used to test shutdown by means of an overcurrent protective device. In order for an overcurrent protective device to be tripped on time, short-circuit current  $I_{SC}$  must be greater than tripping current  $I_a$  (see table 6 in section 23.1). The variants which can be selected with the "Limits" key have the following meanings:

- $I_{SC}$ :  $I_a$  The measured value displayed for  $Z_{L-PE}$  is used without any correction to calculate  $I_{SC}$ .
- $I_{SC}$ :  $I_a + \Delta\%$  The measured value displayed for  $Z_{L-PE}$  is corrected by an amount equal to the test instrument's measuring uncertainty in order to calculate  $I_{SC}$ .
- $I_{SC}$ :  $\frac{2}{3} Z$  In order to calculate  $I_{SC}$ , the measured value displayed for  $Z_{L-PE}$  is corrected by an amount corresponding to all possible deviations (these are defined in detail by VDE 0100-600 (IEC 60364-6) as  $Z_{S(m)} \leq \frac{2}{3} \times U_0 / I_a$ )
- $I_{SC}$ :  $\frac{3}{4} Z$   $Z_{S(m)} \leq \frac{3}{4} \times U_0 / I_a$

$I_{SC}$  Short-circuit current calculated by the instrument (at nominal voltage)  
Z Fault loop impedance

$I_a$  Tripping current (see data sheet for circuit breakers / fuses)  
 $\Delta\%$  Test instrument intrinsic error

### Special case $I_{SC} > I_{SCmax}$

If the short-circuit current value does not lie within the measured values defined in the PROFITEST INTRO, this is indicated by displaying ">ISC-max". In this case, manual evaluation of the measurement results is required.

PE L N BAT MEM

IN 80A 3L < 0.4s 1.5mm<sup>2</sup>

ZL-N 573 mΩ

IK >IK-max 401 A

Limits IK: 2/3Z

LI-N

RLN-OFFSET 0.74 Ω

UN 230V fN 50.0Hz

## Measurement Cable Compensation

The resistance of the connected measurement cable or the country-specific measuring adapter must be compensated, i.e. subtracted from the measurement result as an offset, for each line impedance measurement. Proceed as described in section 8 under "OFFSET RL-PE / RN-PE / RL-N" on page 23 in order to determine offset values **RLPE-OFFSET** and **RNPE-OFFSET**.

## Start Measurement

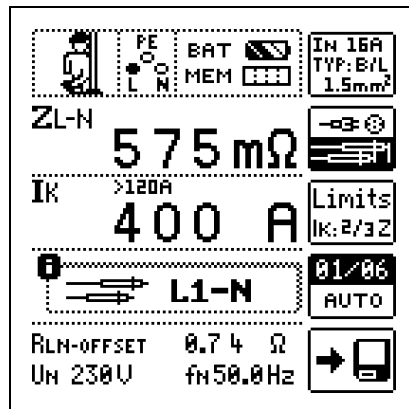
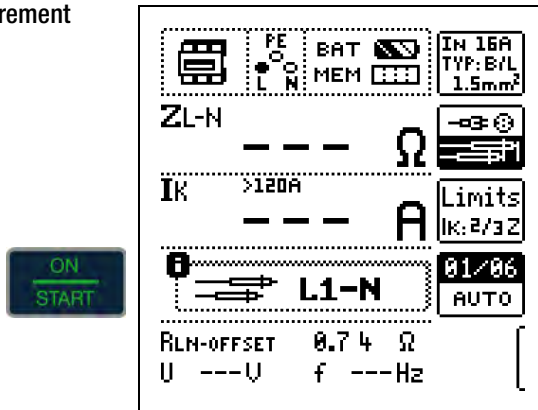

## Display of $U_{L-N}$ ( $U_N / f_N$ )

If the measured voltage value lies within a range of  $\pm 10\%$  of the respective nominal line voltage of 120, 230 or 400 V, the respectively corresponding nominal line voltage is displayed. In the case of measured values outside of the  $\pm 10\%$  tolerance, the actual measured value is displayed.

## Displaying the Fuse Table

After measurement has been performed, allowable fuse types can be displayed by pressing the HELP key.

The table shows maximum permissible nominal current dependent on fuse type and breaking requirements.

	In	gL/gG	In
A	80A	<5s	50A
B/L	50A	<0.4s	32A
E	40A	<0.2s	25A
C/G	25A	<1s	40A
D	13A		
K	16A		
H	100A		

Key:  $I_a$  = breaking current,  $I_{SC}$  = short-circuit current,  $I_N$  = nominal current,  $t_A$  = tripping time

## 15 Earthing Resistance Measurement (function R<sub>E</sub>)

Earthing resistance  $R_E$  is important for automatic shutdown in system segments. It must have a low value in order to assure that high short-circuit current flows and the system is shut down reliably by the RCCB in the event of a fault.

### Test Setup

Earthing resistance ( $R_E$ ) is the sum of the earth electrode's dissipation resistance and earth conductor resistance. Earthing resistance is measured by applying an alternating current via the earth conductor, the earth electrode and dissipation resistance.

### Measurement Without Probe (mains powered earthing measurement)

In many cases, especially in extremely built-up areas, it's difficult, or even impossible, to set a measuring probe. In such cases, earthing resistance can be measured without a probe. In this case, however, the resistance values for the operational earth electrode  $R_B$  and phase conductor L are also included in the measurement results.

### Measuring Method with Suppression of RCD Tripping (mains powered earthing measurement)

The test instrument generates a direct current to this end, which saturates the RCCB's magnetic circuit.

The test instrument then superimposes a measuring current which only demonstrates half-waves of like polarity. The RCCB is no longer capable of detecting this measuring current, and is consequently not tripped during measurement.

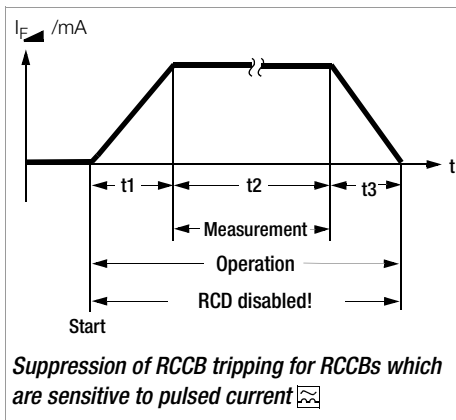

### Limit Values

Earthing resistance (earth coupling resistance) is determined primarily by the electrode's contact surface and the conductivity of the surrounding earth.

The specified limit value depends on the type of electrical system and its shutdown conditions in consideration of maximum touch voltage.

### Evaluating Measured Values

The maximum permissible displayed resistance values which assure that the required earthing resistance is not exceeded, and for which maximum device operating error has already been taken into consideration (at nominal conditions of use), can be determined with the help of Table 2 on page 59. Intermediate values can be interpolated.



## 15.1 Earthing Resistance, Mains Operation – 2-Pole Measurement with KS-PROFITEST INTRO or Country-Specific Measuring Adapter (Schuko)

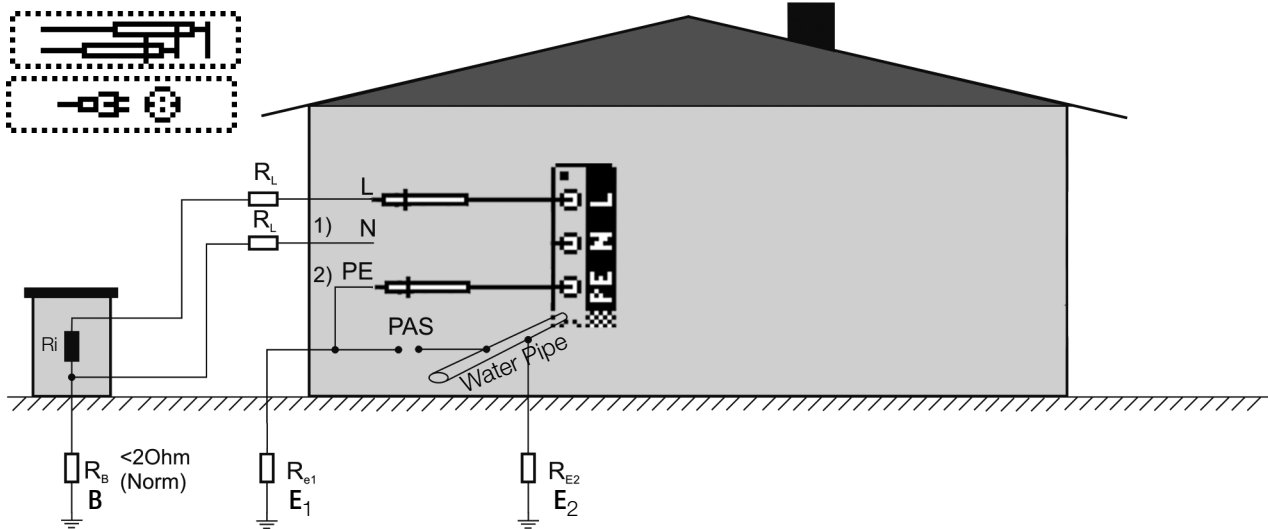

### Key

- $R_B$  Operational earth
- $R_E$  Earthing resistance
- $R_i$  Internal resistance
- $R_X$  Earthing resistance through equipotential bonding systems
- $R_S$  Probe resistance
- PAS Equipotential bonding busbar
- $R_{E_{\text{total}}}$  Overall earthing resistance ( $R_{E1} // R_{E2} // \text{water pipe}$ )

Earthing resistance can be estimated without a probe using the “earth loop resistance measurement”.

The resistance value  $R_{E_{\text{Loop}}}$  obtained with this measuring method also includes operational earth electrode resistance  $R_B$  and resistance at phase conductor L. These values must be subtracted from the measured value in order to determine earthing resistance.

If conductors of equal cross section are assumed (phase conductor L and neutral conductor N), phase conductor resistance is half as great as supply impedance  $Z_{L-N}$  (phase conductor + neutral conductor).

Supply impedance can be measured as described in section 14 beginning on page 46. In accordance with DIN VDE 0100, the operational earth electrode  $R_B$  must lie within a range of “0  $\Omega$  to 2  $\Omega$ ”.

1) Measurement:  $Z_{L-N}$  amounts to  $R_i = 2 \times R_L$

2) Measurement:  $Z_{L-PE}$  amounts to  $R_{E_{\text{Loop}}}$

3) Calculation:  $R_{E1}$  amounts to  $Z_{L-PE} - 1/2 \times Z_{L-N}$ ; where  $R_B = 0$

The value for operational earth conductor resistance  $R_B$  should be ignored in the calculation of earthing resistance, because it's generally unknown.

The calculated earthing resistance thus includes operational earth conductor resistance as a safety factor.

If the  parameter is selected, steps 1 through 3 are executed automatically by the test instrument.

### Set Parameters

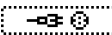
- Measuring range:** AUTO, 10 k $\Omega$  (4 mA), 1 k $\Omega$  (40 mA), 100  $\Omega$  (0.4 A), 10  $\Omega$  (> 0.8 A). In systems with RCCBs, resistance or test current must be selected such that it is less than tripping current ( $1/2 \times I_{\Delta N}$ ).
- Connection:** 2-pole or Schuko (country-specific)
  -  2-pole measurement via KS-PROFITEST INTRO (Z503L), measuring range: max. 10 k $\Omega$  or
  - 2-pole measurement via PRO-Schuko measuring adapter (Z503K), measuring range: max. 10 k $\Omega$
  -  2-pole measurement via PRO-Schuko measuring adapter (Z503K), measuring range limited to 10  $\Omega$  because accurate measurement via formula
- Touch voltage:** UL < 25 V, < 50 V, < 65 V, < xx V
- Test current waveshape:** Sinusoidal (full-wave), 15 mA sinusoidal (full-wave), DC offset (DC-L or DC-H) and positive half-wave
- DC-L:** Reduced bias current but faster measurement as a result
- DC-H:** Higher bias current providing more reliability with regard to non-tripping of the RCD

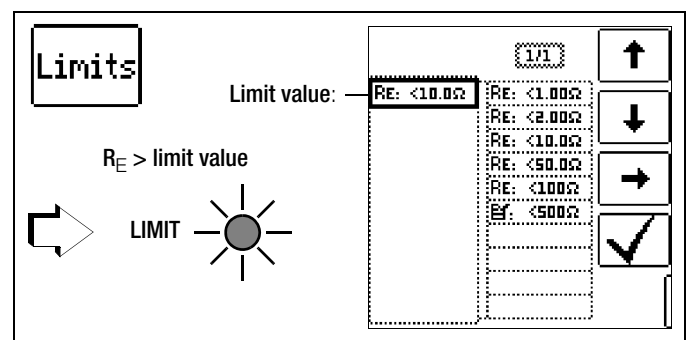

### Select Measuring Function

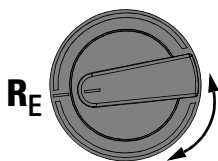

## Measurement Cable Compensation

The resistance of the connected measurement cable or the country-specific measuring adapter must be compensated, i.e. subtracted from the measurement result as an offset, for each earth resistance measurement. Proceed as described in section 8 under "OFFSET RL-PE / RN-PE / RL-N" on page 23 in order to determine offset values **RLPE-OFFSET** and **RNPE-OFFSET**.

### Start Measurement

2-pin

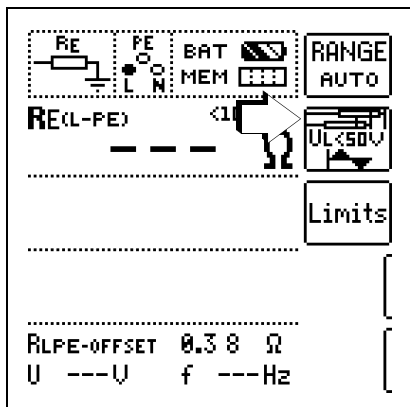

### Start Measurement

Schuko  
(country specific)

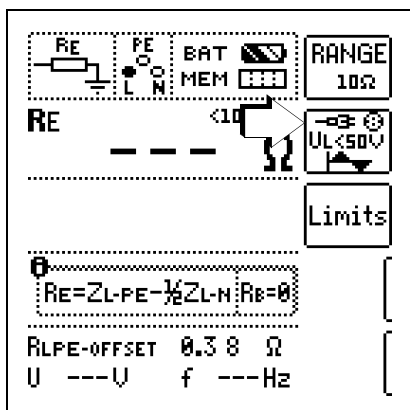

## 16 Measurement of Insulation Resistance



### Attention!

Insulation resistance can only be measured at voltage-free objects.

### 16.1 General

#### Select Measuring Function

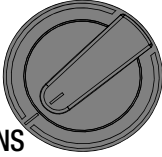

#### Connection

2-pole or test plug

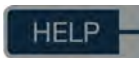
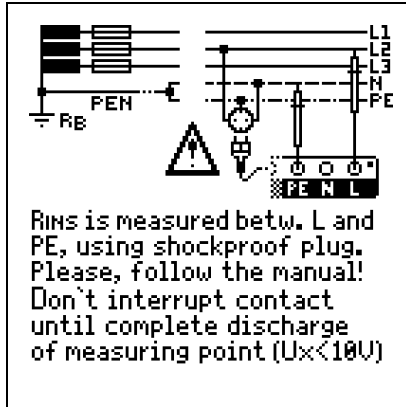

#### Note

If you use the country-specific measuring adapter, insulation resistance is only measured between the phase conductor terminal designated "L" and protective conductor terminal PE!



#### Note

##### Checking Measurement Cables Before Measurements

Before performing insulation measurement, the test probes on the measurement cables should be short-circuited in order to assure that the instrument displays a value of less than 1 k $\Omega$ . In this way, incorrect connection can be avoided and interrupted measurement cables can be detected.

#### Set Parameters

Test voltage: 50 V / 100 V / 250 V / 325 V / 500 V / 1000 V xxx V\*

Voltage type: constant

Voltage type: rising/ramp

Earth leakage resistance:

\* Freely adjustable voltage (see section 10.8)

#### Polarity Selection

**L1-PE** 2-pole measurement (selection relevant for report generation only):  
Measurements between: Lx-PE / N-PE / L+N-PE / Lx-N / Lx-Ly / AUTO\* where x, y = 1, 2, 3

\* AUTO parameter (see section 10.9)

#### Breakdown Current for Ramp Function

**I<sub>LIM</sub>**  $U_{ISO} (U_{INS})$  Limit value: I: 1.00mA  
I: 50uA  
I: 500uA  
I: 1.00mA  
I: 1.25mA  
Ef: 750uA

$I > I_{Limit}$  STOP

#### Limit Values for Breakdown Voltage

**Limits**  $U_{ISO} (U_{INS})$  Lower limit value: U: >250V Upper limit value: U: <750V  
Adjustable range: > 40 V ... < 999 V

#### Limit Values for Constant Test Voltage

**Limits**  $U_{ISO} (U_{INS})$  Limit value: R: >1.0M $\Omega$   
R: >0.1M $\Omega$   
R: >0.3M $\Omega$   
R: >0.5M $\Omega$   
R: >1.0M $\Omega$   
R: >2.0M $\Omega$   
R: >10.0M $\Omega$   
Ef: >100M $\Omega$

$R_{INS} < \text{limit value}$  LIMIT

#### Test voltage

A test voltage which deviates from nominal voltage, and is usually lower, can be selected for measurements at sensitive components, as well as systems with voltage limiting devices.

#### Voltage Type

The " $U_{INS}$ " rising test voltage function (ramp function) is used to detect weak points in the insulation, as well as to determine response voltage for voltage limiting components. After pressing the ON/START key, test voltage is continuously increased until specified nominal voltage  $U_N$  is reached.  $U$  is the voltage which is measured at the test probes during and after testing. This voltage drops to a value of less than 10 V after measurement (see section entitled "Discharging the Device Under Test").

Insulation measurement with rising test voltage is ended:

- As soon as specified maximum test voltage  $U_N$  is reached and the measured value is stable

or

- As soon as specified maximum test voltage is reached (e.g. after sparkover occurs at breakdown voltage).

Specified maximum test voltage  $U_N$  or any occurring triggering or breakdown voltage is displayed for  $U_{INS}$ .

The constant test voltage function offers two options:

- **After briefly pressing the ON/START** key, specified test voltage  $U_N$  is read out and insulation resistance  $R_{INS}$  is measured. As soon as the measured value is stable (settling time may be several seconds in the case of high cable capacitance values), measurement is ended and the last measured values for  $R_{INS}$  and  $U_{INS}$  are displayed.  $U$  is the voltage which is measured at the test probes **during and after testing**. This voltage drops to a value of less than 10 V after measurement (see section entitled “Discharging the Device Under Test”).

or

- **As long as** you press the **ON/START** key, test voltage  $U_N$  is applied and insulation resistance  $R_{INS}$  is measured. Do not release the key until the measured value has settled in (settling time may be several seconds in the case of high cable capacitance values). Voltage  $U$ , which is measured during testing, corresponds to voltage  $U_{INS}$ . After releasing the **ON/START** key, measurement is ended and the last measured values for  $R_{INS}$  and  $U_{INS}$  are displayed.  $U$  drops to a value of less than 10 V after measurement (see the section entitled “Discharging the Device Under Test”).

#### □ Pole Selection Report Entry

The poles between which testing takes place can only be entered here for reporting purposes. The entry itself has no influence on the actual polarity of the test probes or the pole selection.

#### □ Limits – Setting the Limit Value

The limit value for insulation resistance can be set as desired. If measured values occur which are below this limit value, the red **LIMIT LED** lights up. A selection of limit values ranging from 0.5 MΩ to 10 MΩ is available. The limit value is displayed above the measured value.

### Start Measurement – Rising Test Voltage (ramp function)

Press briefly:

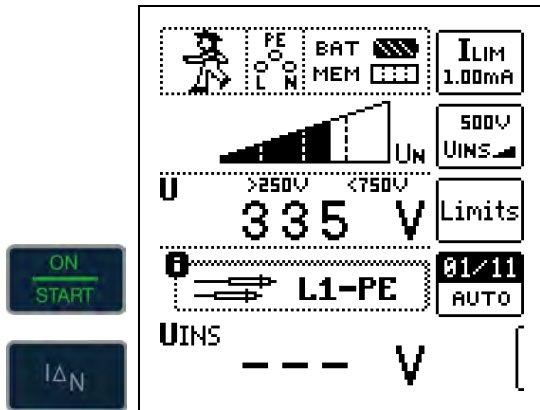

Quick polarity reversal if parameter is set to AUTO: 01/10 ... 10/10:  
L1-PE ... L1-L3



#### Note

If “semiautomatic polarity reversal” is selected (see section 10.9), the corresponding icon is displayed instead of the ramp.

### General Notes Regarding Insulation Measurements with Ramp Function

Insulation measurement with ramp function serves the following purposes:

- Detect weak points in the test object’s insulation
- Determine tripping voltage of voltage limiting components and test them for correct functioning. These components may include, for example, varistors, overvoltage limiters (e.g. DEHNguard® from Dehn+Söhne) and spark gaps.

The test instrument uses continuously rising test voltage for this measuring function, up to the maximum selected voltage limit.

The measuring procedure is started by pressing the **ON/START** key and runs automatically until one of the following events occurs:

- The selected voltage limit is reached
  - The selected current limit is reached
- or
- Sparkover occurs (spark gaps)

Differentiation is made amongst the following three procedures for insulation measurement with ramp function:

#### Testing overvoltage limiters or varistors and determining their tripping voltage:

- Select maximum voltage such that the anticipated breakdown voltage of the device under test is roughly one third of this value (observe manufacturer’s data sheet if applicable).
- Select the current limit value in accordance with actual requirements or the manufacturer’s data sheet (characteristic curve of the device under test).

#### Determining tripping voltage for spark gaps:

- Select maximum voltage such that the anticipated breakdown voltage of the device under test is roughly one third of this value (observe manufacturer’s data sheet if applicable).
- Select the current limit value in accordance with actual requirements within a range of 5 to 10 μA (response characteristics are too unstable with larger current limit values, which may result in faulty measurement results).

#### Detecting weak points in the insulation:

- Select maximum voltage such that it does not exceed the test object’s permissible insulation voltage; it can be assumed that an insulation fault will occur even with a significantly lower voltage if an accordingly lower maximum voltage value is selected (nevertheless at least greater than anticipated breakdown voltage) – the ramp is less steep as a result (increased measuring accuracy).
- Select the current limit value in accordance with actual requirements within a range of 5 to 10 μA (see also settings for spark gaps).

### Start Measurement – Constant Test Voltage

Press and hold for long-term measurement:

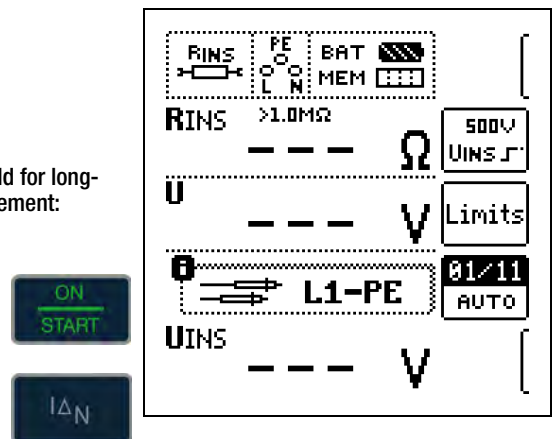

Quick polarity reversal if parameter is set to AUTO: 01/10 ... 10/10:  
L1-PE ... L1-L3



#### Note

The instrument’s (rechargeable) batteries or battery pack are exposed to excessive stress during insulation resistance measurement. When using the “constant test voltage” function, only press and hold the **ON/START** key until the display has become stable (if long-term measurement is required).

## Special Condition for Insulation Resistance Measurement



### Attention!

Insulation resistance can only be measured at voltage-free objects.

If measured insulation resistance is less than the selected limit value, the **LIMIT LED** lights up.

If an interference voltage of  $\geq 25$  V is present within the system, insulation resistance is not measured. The **MAINS/NETZ LED** lights up and the "interference voltage" pop-up message appears.

All conductors (L1, L2, L3 and N) must be tested against PE!



### Attention!

Do not touch the instrument's terminal contacts during insulation resistance measurements!

If nothing has been connected to the terminal contacts, or if a resistive load component has been connected for measurement, your body would be exposed to a current of approximately 1 mA at a voltage of 1000 V. The perceptible shock may lead to injury (e.g. resulting from a startled reaction etc.).

## Discharging the Device Under Test



### Attention!

If measurement is performed at a capacitive object such as a long cable, it becomes charged with up to approx. 1000 V! **Touching such objects is life endangering!**

When an insulation resistance measurement has been performed on a capacitive object it's automatically discharged by the instrument after measurement has been completed. Contact with the device under test must be maintained to this end. The falling voltage value can be observed at the U display.

**Do not disconnect the DUT until less than 10 V is displayed for U!**

## Evaluating Measured Values

Instrument measuring error must be taken into consideration in order to assure that the limit values set forth in DIN VDE regulations are not fallen short of. The required minimum display values for insulation resistance can be determined with the help of Table 3 on page 59. These values take maximum device error into consideration (under nominal conditions of use). Intermediate values can be interpolated.

### 16.2 Special Case: Earth Leakage Resistance (REINS)

This measurement is performed in order to determine electrostatic discharge capacity for floor coverings in accordance with EN 1081.

## Select Measuring Function

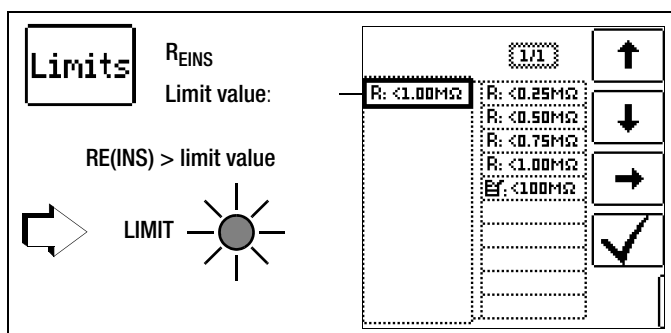
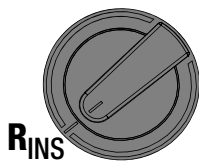

## Set Parameters

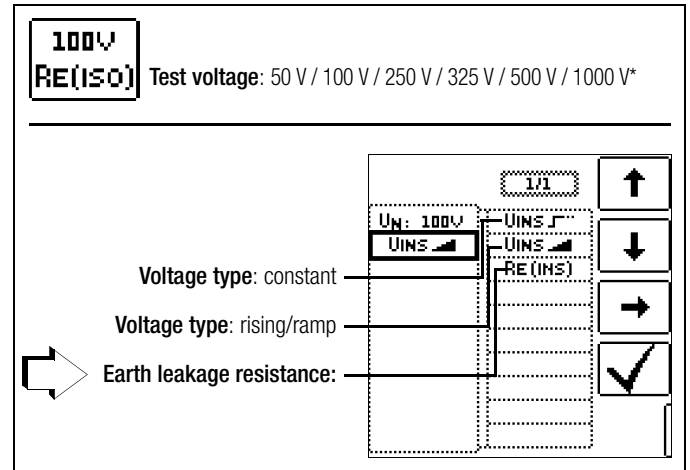

\* Freely adjustable voltage (see section 10.8)

## Connection and Test Setup

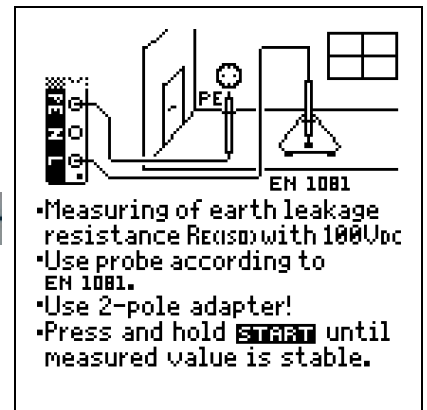

- Rub the floor covering at the point at which measurement is to be performed with a dry cloth.
- Place the 1081 floor probe onto the point of measurement and load it with a weight of at least 300 N (30 kg). This corresponds to EN 1081. A load of 750 N (75 kg) is in accordance with DIN VDE 0100-600 (IEC 60364-6).
- Establish a conductive connection between the measuring electrode and the test probe and connect the measuring adapter (2-pole) to an earth contact, e.g. the earthing contact at a mains outlet or a central heating radiator (prerequisite: reliable ground connection).

## Start Measurement

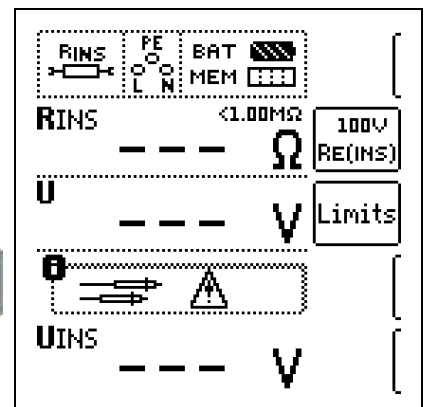

The limit value for earth leakage resistance from the relevant regulations applies.

## 17 Measuring Low-Value Resistance of up to 200 Ω (protective conductor and equipotential bonding conductor)

According to the regulations, the measurement of low-value resistance at protective conductors, earth conductors or bonding conductors must be performed with (automatic) polarity reversal of the test voltage, or with current flow in one (+ pole to PE) and then the other direction (– pole to PE).

### Attention!

Low-resistance may only be measured at voltage-free objects.

### Select Measuring Function

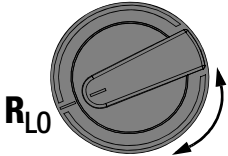

### Connection

2-pin

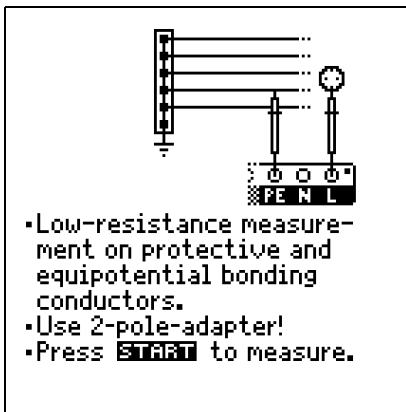
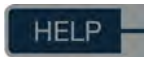

### Set Parameter

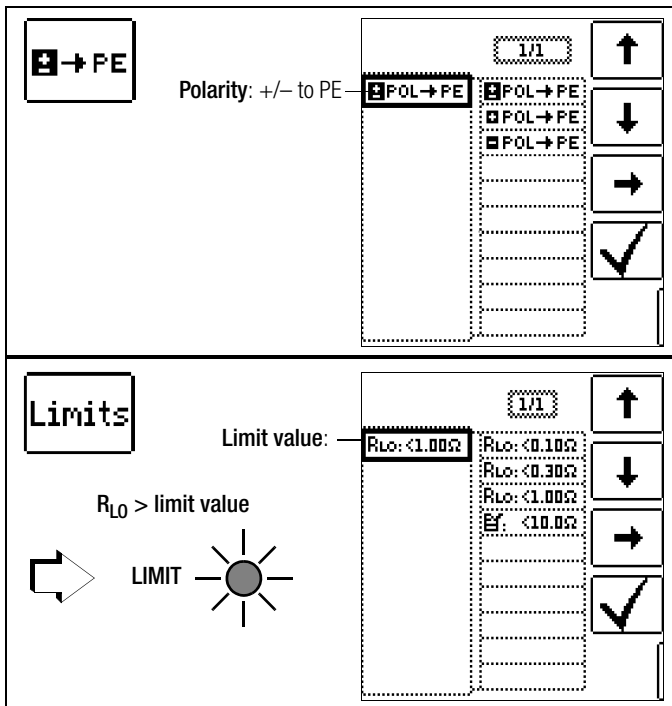

### Compensation for Measurement Cables Up to 10 Ω

If measurement cables or extension cables are used, their resistance can be automatically subtracted from the measurement results. Proceed as follows:

### Measuring ROFFSET

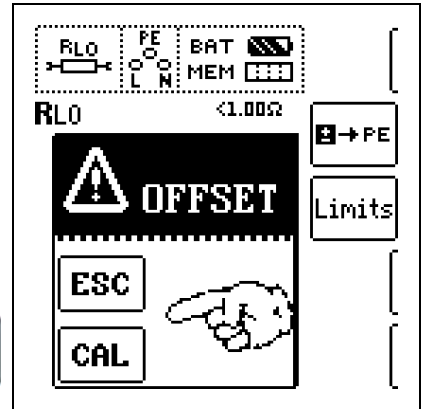
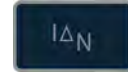

- Select a polarity option or automatic polarity reversal.
- Open the **OFFSET** menu by pressing  $I_{\Delta N}$ .
- Using the **PRO-Schuko measuring adapter (Z503K)**: Short circuit the L and N contacts at the test plug by inserting it into the short-circuiting jumper (PRO-JUMPER, Z503J).
- Using the **KS-PROFITEST INTRO (Z503L) or Z550A**: Short circuit the test probes of the connected, and if applicable extended, test leads by inserting the test probes into the short-circuiting jumper (PRO-JUMPER, Z503J).
- Start measurement of offset resistance with  $I_{\Delta N}$  or **CAL**.

### Note

If offset measurement is stopped upon appearance of a pop-up error window ( $R_{offset} > 10 \Omega$  or difference between  $R_{LO+}$  and  $R_{LO-}$  of greater than 10%), the last measured offset value is retained. Inadvertent deletion of a previously ascertained offset value is thus practically ruled out. The respectively smaller value is otherwise stored to memory as an offset value. The maximum offset value is 10.0 Ω. Negative resistances may result due to the offset value.

The **ROFFSET** x.xx Ω message now appears in the footer at the display, where x.xx is a value between 0.00 and 10.0 Ω. This value will now be deducted from the actual measured value for all subsequent  $R_{LO}$  measurements.

When switching amongst polarity options, **ROFFSET** is reset to 0.00 Ω and must be determined again.

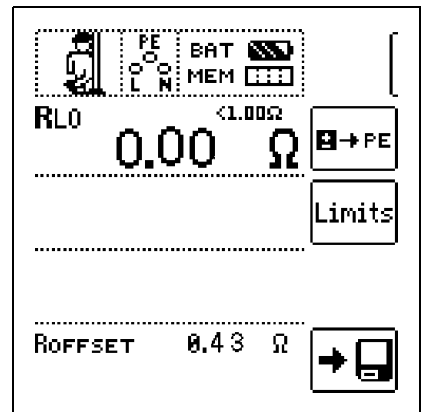

### Note

Use this function as a standard procedure for all measurement cables. Whenever different extension and measurement and cables are used, the above described procedure must always be repeated.

### □ Type / Polarity

The direction in which current flows can be selected here.

### □ Limits – Setting the Limit Value

The limit value for resistance can be set as desired. If measured values occur which are above this limit value, the red **LIMIT LED** lights up. Limit values can be selected within a range of 0.10 Ω to 10.0 Ω (editable). The limit value is displayed above the measured value.

## 17.1 Measurement with Constant Test Current

### Start Measurement



Press and hold for long-term measurement:

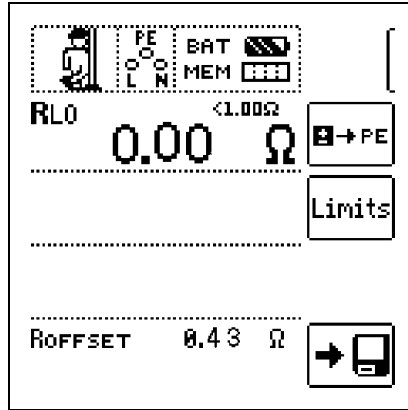

#### Attention!

The test probes should always be in contact with the DUT before the ON/START key is activated.

If the DUT is energized, measurement is disabled as soon as it's contacted with the test probes.

If the ON/START key is pressed first and the test object is contacted with the test probes afterwards, the fuse blows.

In the case of single-pole measurement, the respective value is saved to the database as RLO.

Polarity Selection	Display	Condition
+ pole to PE	<b>RLO+</b>	None
- pole to PE	<b>RLO-</b>	None
± pole to PE	<b>RLO</b>	Where $\Delta RLO \leq 10\%$
	<b>RLO+</b> <b>RLO-</b>	Where $\Delta RLO > 10\%$

### Automatic Polarity Reversal

After the measuring sequence has been started, the instrument performs the measurement with automatic polarity reversal, first with current flow in one direction, and then in the other. In the case of long-term measurement (press and hold the ON/START key), polarity is switched once per second.

If the difference between RLO+ and RLO- is greater than 10% with automatic polarity reversal, RLO+ and RLO- values are displayed instead of RLO. The respectively larger value, RLO+ or RLO-, appears at the top and is saved to the database as the RLO value.

### Evaluating Measurement Results

Differing results for measurements in both directions indicate voltage at the DUT (e.g. thermovoltages or unit voltages).

## 18 Special Functions – EXTRA Switch Position

Select the EXTRA switch position.



### 18.1 Voltage Drop Measurement (with $Z_{LN}$ ) – $\Delta U$ Function

#### Significance and Display of $\Delta U$ (per DIN VDE 100-600)

Voltage drop from the intersection of the distribution network and the consumer system to the point of connection of an electrical power consumer (electrical outlet or device connector terminals) should not exceed 5% of nominal line voltage.

Calculating voltage drop (without offset):

$$\Delta U = Z_{L-N} \times \text{nominal current of the fuse}$$

Calculating voltage drop (with offset):

$$\Delta U = (Z_{L-N} - Z_{\text{OFFSET}}) \times \text{nominal current of the fuse}$$

$$\Delta U \text{ in } \% = 100 \times \Delta U / U_{L-N}$$

See also section 14 regarding the measurement procedure and connection.

#### Connection and Test Setup

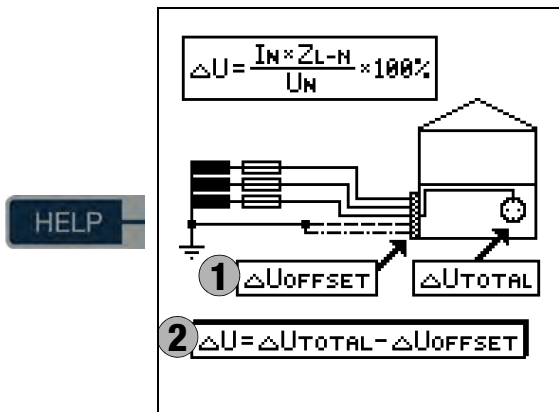

#### Set Parameter

L1-N	L1-N
L2-N	L2-N
L3-N	L3-N
L1-L2	L1-L2
L2-L3	L2-L3
L1-L3	L1-L3
L-N	L-N

**Note:** If nominal current  $I_N$  is changed by  $\Delta U_{\text{OFFSET}}$ , the offset value is automatically adjusted.

#### Set Limit Values

VDE	<4.00%
TAB	<0.50%
TAB	<1.00%
TAB	<1.25%
TAB	<1.50%
DIN	<3.00%
VDE	<4.00%
NL	<5.00%
EF	<10.0%

- TAB Limit value per German technical connection conditions for connection to low-voltage mains between the distribution network and the measuring device
- DIN Limit value per DIN 18015-1:  $\Delta U < 3\%$  between the measuring device and the consuming device
- VDE Limit value per DIN VDE 0100-520:  $\Delta U < 5\%$  between the distribution network and the consuming device (adjustable up to 10% in this case)
- NL Limit value per NIV:  $\Delta U < 5\%$

#### Start Measurement Without OFFSET

Proceed as follows:

- Switch **OFFSET** from ON to OFF.

#### Determining RLN OFFSET

Depending on which measurement cable or measuring adapter is connected, an offset measurement must first be performed in the **SETUP** switch position (see page 23). The offset value ascertained in this way is displayed in the footer as **RLN OFFSET** and is subtracted from the measurement results.

#### Start measurement with OFFSET.



## 19 Maintenance

### 19.1 Firmware Version and Calibration Information

See section 8.

### 19.2 (Rechargeable) Battery (Pack) Care

Check to make sure that no leakage has occurred at the (rechargeable) batteries (either individual or in the battery pack) at short, regular intervals, or after the instrument has been in storage for a lengthy period of time.



#### Note

Remove (rechargeable) batteries or the battery pack during lengthy periods of non-use (e.g. vacation). This prevents excessive depletion or leakage, which may result in damage to the test instrument.

### 19.3 Fuses

If a fuse has blown due to overloading, a corresponding message error appears at the display panel. The instrument's voltage measuring ranges are nevertheless still functional.

- ⇨ Disconnect the instrument from the measuring circuit at all poles!
- ⇨ Open the battery compartment lid by loosening the two screws.
- ⇨ Remove the blown fuse and insert a new one.



#### Attention!

Severe damage to the instrument may occur if incorrect fuses are used.

Only original fuses from Gossen Metrawatt GmbH may be used (order no. 3-578-285-01 / SIBA 7012540.3,15 SI-EINSATZ FF 3,15A/600V (6.3X32).

Only original fuses assure required protection by means of suitable blowing characteristics. Short-circuiting of fuse terminals or the repair of fuses is prohibited, and is life endangering!

The instrument may be damaged if fuses with incorrect ampere ratings, breaking capacities or blowing characteristics are used!

- ⇨ Insert the new fuse.
- ⇨ Replace the battery compartment lid and retighten the screw.

### 19.4 Housing

No special maintenance is required for the housing. Keep outside surfaces clean. Use a slightly dampened cloth for cleaning. In particular for the protective rubber surfaces, we recommend a moist, lint-free microfiber cloth. Avoid the use of cleansers, abrasives or solvents.

## 20 Contact, Support and Service

Gossen Metrawatt GmbH can be reached directly and simply – we have a single number for everything! Whether you require support or training, or have an individual inquiry, we can answer all of your questions here:

+49-911-8602-0

Monday to Thursday: 8 a.m. to 4 p.m.

Friday: 8 a.m. to 2 p.m.

Or contact us by e-mail at: [info@gossenmetrawatt.com](mailto:info@gossenmetrawatt.com)

Do you prefer support by e-mail?

Measuring and Test Technology:  
[support@gossenmetrawatt.com](mailto:support@gossenmetrawatt.com)

Industrial Measuring Technology:  
[support.industrie@gossenmetrawatt.com](mailto:support.industrie@gossenmetrawatt.com)

Enquiries concerning training and seminars can also be submitted by e-mail and online:

[training@gossenmetrawatt.com](mailto:training@gossenmetrawatt.com)

<https://www.gossenmetrawatt.com/training>



Please contact GMC-I Service GmbH for repairs, replacement parts and calibration<sup>1)</sup>:

+49-911-817718-0

[service@gossenmetrawatt.com](mailto:service@gossenmetrawatt.com)

[www.gmci-service.com](http://www.gmci-service.com)

Beuthener Str. 41  
D-90471 Nürnberg  
Germany



## 21 CE Declaration

The instrument fulfills all requirements of applicable EU directives and national regulations. We confirm this with the CE mark. The CE declaration can be found on our website:

<https://www.gossenmetrawatt.de/en/services/download-center/>



<sup>1)</sup> DAkkS calibration laboratory per DIN EN ISO/IEC 17025 accredited by the Deutsche Akkreditierungsstelle GmbH under reference number D-K-15080-01-01.

## 22 Disposal and Environmental Protection

Proper disposal makes an important contribution to the protection of our environment and the conservation of natural resources.



### Attention!

Environmental Damage  
Improper disposal results in environmental damage.  
Follow the instructions concerning return and disposal included in this section.

The following comments refer specifically to the legal situation in the Federal Republic of Germany. Owners or end users who are subject to other national regulations must comply with the respectively applicable requirements and implement them correctly on site. Relevant information can be obtained, for example, from the responsible national authorities or national distributors.

### Waste Electrical Equipment, Electrical or Electronic Accessories and Waste Batteries (including rechargeable batteries)

Electrical equipment and batteries (including rechargeable batteries) contain valuable raw materials that can be recycled, as well as hazardous substances which can cause serious harm to human health and the environment, and they must be recycled and disposed of correctly.



The symbol at the left depicting a crossed-out garbage can on wheels refers to the legal obligation of the owner or end user (German electrical and electronic equipment act ElektroG and German battery act BattG) not to dispose of used electrical equipment and batteries with unsorted municipal waste ("household trash"). Waste batteries must be removed from the old device (where

possible) without destroying them and the old device and the waste batteries must be disposed of separately. The battery type and its chemical composition are indicated on the battery's labeling. If the abbreviations "Pb" for lead, "Cd" for cadmium or "Hg" for mercury are included, the battery exceeds the limit value for the respective metal.

Please observe the owner's or end user's responsibility with regard to deleting personal data, as well as any other sensitive data, from old devices before disposal.

Old devices, electrical or electronic accessories and waste batteries (including rechargeable batteries) used in Germany can be returned free of charge to Gossen Metrawatt GmbH or the service provider responsible for their disposal in compliance with applicable regulations, in particular laws concerning packaging and hazardous goods. Further information regarding returns can be found on our website.

### Packaging Materials

We recommend retaining the respective packaging materials for the case that you might require servicing or calibration in the future.



### Attention!

Danger of Asphyxiation Resulting from Foils and Other Packaging Materials  
Children and other vulnerable persons may suffocate if they wrap themselves in packaging materials, or their components or foils, or if they pull them over their heads or swallow them.  
Keep packaging materials, as well as their components and foils, out of the reach of babies, children and other vulnerable persons.

In accordance with German packaging law (VerpackG), the user is obligated to correctly dispose of packaging and its components separately, and not together with unsorted municipal waste ("household trash").

Private end consumers can dispose of packaging free of charge at the responsible collection point. Packaging which is not subject to so-called system participation is returned to the appointed service provider. Further information regarding returns can be found on our website.

## 23 Appendix

### 23.1 Tables for the determination of maximum or minimum display values under consideration of maximum measuring uncertainty:

Table 1

$Z_{L-PE}$ (full-wave) / $Z_{L-N}$ ( $\Omega$ )		$Z_{L-PE}$ ( $\pm$ half-wave) ( $\Omega$ )	
Limit Value	Max. Display Value	Limit Value	Max. Display Value
0.10	0.07	0.10	0.05
0.15	0.11	0.15	0.10
0.20	0.16	0.20	0.14
0.25	0.20	0.25	0.18
0.30	0.25	0.30	0.22
0.35	0.30	0.35	0.27
0.40	0.34	0.40	0.31
0.45	0.39	0.45	0.35
0.50	0.43	0.50	0.39
0.60	0.51	0.60	0.48
0.70	0.60	0.70	0.56
0.80	0.70	0.80	0.65
0.90	0.79	0.90	0.73
1.00	0.88	1.00	0.82
1.50	1.40	1.50	1.33
2.00	1.87	2.00	1.79
2.50	2.35	2.50	2.24
3.00	2.82	3.00	2.70
3.50	3.30	3.50	3.15
4.00	3.78	4.00	3.60
4.50	4.25	4.50	4.06
5.00	4.73	5.00	4.51
6.00	5.68	6.00	5.42
7.00	6.63	7.00	6.33
8.00	7.59	8.00	7.24
9.00	8.54	9.00	8.15
9.99	9.48	9.99	9.05

Table 3

Limit Value	$R_{INS}$ $M\Omega$		
	Min. Display Value	Limit Value	Min. Display Value
0.10	0.12	10.0	10.7
0.15	0.17	15.0	15.9
0.20	0.23	20.0	21.2
0.25	0.28	25.0	26.5
0.30	0.33	30.0	31.7
0.35	0.38	35.0	37.0
0.40	0.44	40.0	42.3
0.45	0.49	45.0	47.5
0.50	0.54	50.0	52.8
0.55	0.59	60.0	63.3
0.60	0.65	70.0	73.8
0.70	0.75	80.0	84.4
0.80	0.86	90.0	94.9
0.90	0.96	100	106
1.00	1.07	150	158
1.50	1.59	200	211
2.00	2.12	250	264
2.50	2.65	300	316
3.00	3.17		
3.50	3.70		
4.00	4.23		
4.50	4.75		
5.00	5.28		
6.00	6.33		
7.00	7.38		
8.00	8.44		
9.00	9.49		

Table 2

Limit Value	Max. Display Value	$R_E / R_{ELoop}$ ( $\Omega$ )		Limit Value	Max. Display Value
		Limit Value	Max. Display Value		
0.10	0.07	10.0	9.49	1.00 k	906
0.15	0.11	15.0	13.6	1.50 k	1.36 k
0.20	0.16	20.0	18.1	2.00 k	1.81 k
0.25	0.20	25.0	22.7	2.50 k	2.27 k
0.30	0.25	30.0	27.2	3.00 k	2.72 k
0.35	0.30	35.0	31.7	3.50 k	3.17 k
0.40	0.34	40.0	36.3	4.00 k	3.63 k
0.45	0.39	45.0	40.8	4.50 k	4.08 k
0.50	0.43	50.0	45.4	5.00 k	4.54 k
0.60	0.51	60.0	54.5	6.00 k	5.45 k
0.70	0.60	70.0	63.6	7.00 k	6.36 k
0.80	0.70	80.0	72.7	8.00 k	7.27 k
0.90	0.79	90.0	81.7	9.00 k	8.17 k
1.00	0.88	100	90.8	9.99 k	9.08 k
1.50	1.40	150	133		
2.00	1.87	200	179		
2.50	2.35	250	224		
3.00	2.82	300	270		
3.50	3.30	350	315		
4.00	3.78	400	360		
4.50	4.25	450	406		
5.00	4.73	500	451		
6.00	5.68	600	542		
7.00	6.63	700	633		
8.00	7.59	800	724		
9.00	8.54	900	815		

Table 4

Limit Value	Max. Display Value	$R_{LO}$ $\Omega$		Limit Value	Max. Display Value
		Limit Value	Max. Display Value		
0.10	0.07	10.0	9.59		
0.15	0.12	15.0	14.4		
0.20	0.17	20.0	19.2		
0.25	0.22	25.0	24.0		
0.30	0.26	30.0	28.8		
0.35	0.31	35.0	33.6		
0.40	0.36	40.0	38.4		
0.45	0.41	45.0	43.2		
0.50	0.46	50.0	48.0		
0.60	0.55	60.0	57.6		
0.70	0.65	70.0	67.2		
0.80	0.75	80.0	76.9		
0.90	0.84	90.0	86.5		
1.00	0.94	99.9	96.0		
1.50	1.42				
2.00	1.90				
2.50	2.38				
3.00	2.86				
3.50	3.34				
4.00	3.82				
4.50	4.30				
5.00	4.78				
6.00	5.75				
7.00	6.71				
8.00	7.67				
9.00	8.63				

Table 5

Short-Circuit Current Minimum Display Values for the determination of nominal current for various fuses and breakers for systems with nominal voltage of  $U_N = 230\text{ V}$

Nominal Current $I_N$ [A]	Low Resistance Fuses in Accordance with the DIN VDE 0636 Series of Standards Characteristic gL, gG, gM				With Circuit Breaker and Line Switch							
	Breaking Current $I_A$ 5 s		Breaking Current $I_A$ 0.4 s		Characteristic B/E (formerly L) Breaking Current $I_A$ $5 \times I_N (< 0.2\text{ s}/0.4\text{ s})$		Characteristic C (formerly G, U) Breaking Current $I_A$ $10 \times I_N (< 0.2\text{ s}/0.4\text{ s})$		Characteristic D Breaking Current $I_A$ $20 \times I_N (< 0.2\text{ s}/0.4\text{ s})$		Characteristic K Breaking Current $I_A$ $12 \times I_N (< 0.1\text{ s})$	
	Limit Value [A]	Min. Display [A]	Limit Value [A]	Min. Display [A]	Limit Value [A]	Min. Display [A]	Limit Value [A]	Min. Display [A]	Limit Value [A]	Min. Display [A]	Limit Value [A]	Min. Display [A]
	2	9.2	10	16	17	10	11	20	21	40	42	24
3	14.1	15	24	25	15	16	30	32	60	64	36	38
4	19	20	32	34	20	21	40	42	80	85	48	51
6	27	28	47	50	30	32	60	64	120	128	72	76
8	37	39	65	69	40	42	80	85	160	172	96	102
10	47	50	82	87	50	53	100	106	200	216	120	128
13	56	59	98	104	65	69	130	139	260	297	156	167
16	65	69	107	114	80	85	160	172	320	369	192	207
20	85	90	145	155	100	106	200	216	400	467	240	273
25	110	117	180	194	125	134	250	285	500	578	300	345
32	150	161	265	303	160	172	320	369	640	750	384	447
35	173	186	295	339	175	188	350	405	700	825	420	492
40	190	205	310	357	200	216	400	467	800	953	480	553
50	260	297	460	529	250	285	500	578	1000	1.22 k	600	700
63	320	369	550	639	315	363	630	737	1260	1.58 k	756	896
80	440	517									960	1.16 k
100	580	675									1200	1.49 k
125	750	889									1440	1.84 k
160	930	1.12 k									1920	2.59 k

**Example**

Display value of 90.4 A → next lower value for circuit breaker characteristic B from table: 85 A → nominal current ( $I_N$ ) of the protective device: max. 16 A

## 23.2 At which values should/must an RCD actually be tripped? Requirements for Residual Current Devices (RCD)

### General Requirements

- Tripping must occur no later than upon occurrence of rated residual current (nominal differential current  $I_{\Delta N}$ ).
- and
- Maximum time to trip may not be exceeded.

### Additional requirements due to influences on the tripping current range and the point in time of tripping which have to be taken into consideration:

- Residual current type or waveform:  
This results in a permissible tripping current range.
- Mains type and line voltage:  
This results in maximum tripping time.
- RCD variant (standard or selective):  
This results in maximum tripping time.

### Definitions of Requirements in the Standards

**VDE 0100-600 (IEC 60364-6)**, which is included in all German standards collections for **electricians**, applies to measurements in electrical systems. It plainly states: "The effectiveness of the protective measure is substantiated when disconnection occurs no later than upon occurrence of rated differential current  $I_{\Delta N}$ ."

As a requirement for the **measuring instrument manufacturer**, **DIN EN 61557-6 (VDE 0413-6)** unmistakably specifies:





"The measuring instrument must be capable of substantiating the fact that the residual current which trips the residual current device (RCD) is less than or equal to rated residual current."

### Comment

For all electricians, this means that during scheduled testing of protective measures after system modifications or additions to the system, as well as after repairs or during the E-check conducted after measurement of touch voltage, the tripping test must be conducted no later than upon reaching a value of, depending upon the RCD, 10 mA, 30 mA, 100 mA, 300 mA or 500 mA. How does the electrician react in the event that these values are exceeded? The RCD is replaced!

If it was relatively new, a complaint is submitted to the manufacturer. And if the manufacturer's test lab determines: The RCD complies with the manufacturer's standard and is OK.

A look at the VDE 0664-10/-20/-100/-200 manufacturer's standard shows us why:

Type of Residual Current	Residual Current	Waveform	Permissible Tripping Current Range
Sinusoidal alternating current			0.5 ... 1 $I_{\Delta N}$
Pulsating direct current (positive or negative half-waves)			0.35 ... 1.4 $I_{\Delta N}$
Phase angle controlled half-wave currents Phase angle of 90° el Phase angle of 135° el			0.25 ... 1.4 $I_{\Delta N}$ 0.11 ... 1.4 $I_{\Delta N}$
Pulsating direct current superimposed with 6 mA smooth, direct residual current			Max. 1.4 $I_{\Delta N}$ + 6 mA
Smooth direct current			0.5 ... 2 $I_{\Delta N}$

Because the current waveform plays a significant role, the current waveform used by the test instrument is also important.

Set residual current type or waveform at the test instrument:

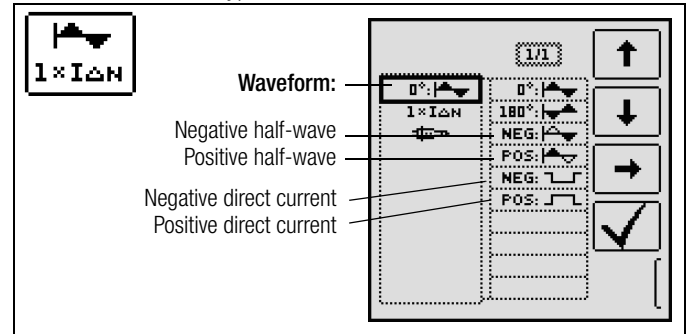

It's important to be able to select and take advantage of the corresponding settings at one's own test instrument.

The situation is similar for breaking times. The new **VDE 0100-410** should also be included in the standards collection. Depending upon mains type and line voltage, it specifies breaking times ranging from 0.1 to 5 seconds.

System	50 V < U <sub>0</sub> ≤ 120 V		120 V < U <sub>0</sub> ≤ 230 V		230 V < U <sub>0</sub> ≤ 400 V		U <sub>0</sub> > 400 V	
	AC	DC	AC	DC	AC	DC	AC	DC
TN	0.8 s		0.4 s	1 s	0.2 s	0.4 s	0.1 s	0.1 s
TT	0.3 s		0.2 s	0.5 s	0.07 s	0.2 s	0.04 s	0.1 s

RCDs usually interrupt more quickly, but in some cases they can take a bit longer. Once again, the ball is in the manufacturer's court.

The following table is also included in **VDE 0664**:

Design	Error Current Type	Breaking Time at			
		1 × $I_{\Delta N}$	2 × $I_{\Delta N}$	5 × $I_{\Delta N}$	500 A
	Alternating residual current	1 × $I_{\Delta N}$	2 × $I_{\Delta N}$	5 × $I_{\Delta N}$	500 A
	Pulsating direct residual current	1.4 × $I_{\Delta N}$	2 × 1.4 × $I_{\Delta N}$	5 × 1.4 × $I_{\Delta N}$	500 A
	Smooth, direct residual current	2 × $I_{\Delta N}$	2 × 2 × $I_{\Delta N}$	5 × 2 × $I_{\Delta N}$	500 A
Standard (undelayed) or briefly delayed		300 ms	Max. 0.15 s	Max. 0.04 s	Max. 0.04 s
Selective		0.13 ... 0.5 s	0.06 ... 0.2 s	0.05 ... 0.15 s	0.04 ... 0.15 s

Two limit values are highly conspicuous:

- Standard Max. 0.3 s
- Selective Max. 0.5 s

All of the limit values are already included in good test instruments, or it's possible to enter them directly and they're displayed as well!

Select or set limit values at the test instrument:

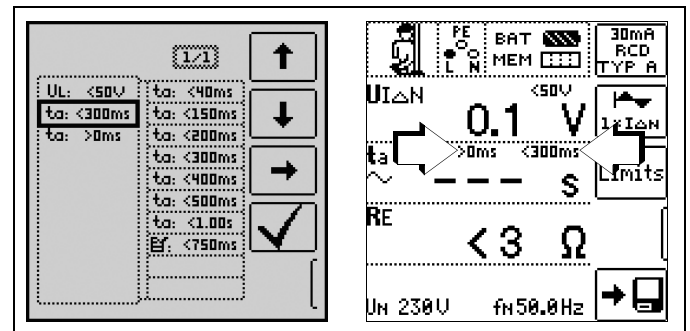

Tests for electrical systems include "visual inspection", "testing" and "measurement", and thus may only be conducted by experts with appropriate work experience.

In the final analysis, the values from VDE 0664 are technically binding.

## 23.3 Bibliography

Statutory Source Documents			
German Occupational Safety Legislation (BetrSichV) Regulations Issued by Accident Insurance Carriers			
Title	Information Rule/Regulation	Publisher	Issue / Order no.
German occupational safety legislation (BetrSichV)	BetrSichV		2015
Electrical systems and equipment	DGUV regulation 3 (formerly BGV A3)	DGUV (formerly HVBG)	2014

VDE Standards			
German Standard	Title	Date of Issue	Publisher
DIN VDE 0100-410	Protection against electric shock	2018-10	Beuth-Verlag GmbH
DIN VDE 0100-530	Low-voltage electrical installations Part 530: Selection and erection of electrical equipment, switchgear and control gear	2018-06	Beuth-Verlag GmbH
DIN VDE 0100-600	Low-voltage electrical installations Part 6: Tests	2017-06	Beuth-Verlag GmbH
Series of standards DIN EN 61557	Devices for testing, measuring or monitoring protective measures	2022-12	Beuth-Verlag GmbH
DIN VDE 0105-100	Operation of electrical installations, Part 100: General requirements	2015-10	Beuth-Verlag GmbH
VDE 0122-1 DIN EN 61851-1	Electric vehicle conductive charging system – Part 1: General requirements	2021-06	Beuth-Verlag GmbH

### Internet Addresses for Additional Information

Internet Address	
<a href="http://www.dguv.de">www.dguv.de</a>	DGUV information, rules and regulations from German statutory accident insurance
<a href="http://www.beuth.de">www.beuth.de</a>	VDE regulations, DIN standards, VDI directives from Beuth-Verlag GmbH
<a href="http://www.bgetem.de">www.bgetem.de</a>	BG information, rules and regulations from the trade associations e.g. BG ETEM (trade association for energy, textiles and electrical medical devices)

---

© Gossen Metrawatt GmbH  
Prepared in Germany • Subject to change, errors excepted

All trademarks, registered trademarks, logos, product names and company names are the property of their respective owners.

Gossen Metrawatt GmbH  
Südwestpark 15  
D-90449 Nürnberg • Germany

Phone +49 911 8602-0  
Fax +49 911 8602-669  
e-mail [info@gossenmetrawatt.com](mailto:info@gossenmetrawatt.com)  
[www.gossenmetrawatt.com](http://www.gossenmetrawatt.com)